

 INCLUDED

300 - 300M SERIES

Installation, Operation
and Maintenance Manual

 **Bonfiglioli**



USE, INSTALLATION AND MAINTENANCE MANUAL

1.0	GENERAL INFORMATION	2
1.1	PURPOSE OF THE MANUAL	2
1.2	PRODUCT IDENTIFICATION	3
1.3	GLOSSARY AND TERMINOLOGY	4
1.4	REQUESTING TECHNICAL ASSISTANCE	4
1.5	MANUFACTURER'S LIABILITY	4
1.6	CONSIGNMENT CONDITIONS	5
2.0	TECHNICAL INFORMATION	5
2.1	DESCRIPTION OF THE GEAR UNIT	5
2.2	CONFORMITY	6
2.3	OPERATING LIMITS AND CONDITIONS	6
2.4	ALLOWED TEMPERATURE LIMITS	7
3.0	SAFETY INFORMATION	8
3.1	SAFETY STANDARDS	8
4.0	HANDLING AND TRANSPORT	9
4.1	PACKAGING	9
4.2	HANDLING INSTRUCTIONS	9
4.2.1	Moving the packages	10
4.2.2	Moving the equipment	10
4.3	STORAGE	17
5.0	INSTALLATION	20
5.1	INSTALLING THE GEAR UNIT	20
5.1.1	Flanged execution	20
5.1.2	Foot mounting	23
5.1.3	Shaft mounting	23
5.1.4	Installing accessories on solid input and output shafts	25
5.1.4	Installation of Gear units supplied without motor connection	27
5.2	INSTALLING THE ELECTRIC MOTOR	27
5.3	INSTALLING THE HYDRAULIC MOTOR	28
5.4	CONNECTING THE HYDRAULIC BRAKE	29
5.5	LUBRICATION	35
6.0	TESTING THE GEAR UNIT	39
7.0	USING THE EQUIPMENT	39
8.0	MAINTENANCE	40
8.1	ROUTINE MAINTENANCE	41
8.2	OIL CHANGES	42
8.3	CHECKING OPERATIONAL EFFICIENCY	43
8.4	CLEANING	43
9.0	REPLACING PARTS	44
9.1	REMOVING THE MOTOR	44
9.2	DECOMMISSIONING THE GEAR UNIT	45
10.0	TROUBLESHOOTING	45
ANNEX 1 - CHECKING THE OIL LEVEL ON ATEX-SPECIFIED GEAR UNITS		46
ANNEX 2 - LUBRICANT CHARGE QUANTITY		47
ANNEX 3 - MOUNTING POSITIONS AND PLUG POSITIONS		51

Revisions

The catalogue revision list is given on page 56. The most recent versions of the catalogue are available at www.bonfiglioli.com.



1.0 GENERAL INFORMATION

1.1 PURPOSE OF THE MANUAL

This Manufacturer's manual provides information regarding the safe transport, handling, installation, maintenance, repair, disassembly and dismantling of the gear unit.

All information for users and designers is given in the Sales Catalogue. As well as adhering to established engineering practices, the information given in this manual must be read carefully and rigorously applied.

Failure to observe the information provided herein may result in risks to personal health and safety, as well as economic damages.

This information, provided in the Manufacturer's original language (Italian), is also available in other languages to meet legal and commercial requirements.

The documentation must be stored by a person charged to do so in a suitable location so as to be always available in good condition for consultation.

In case of loss or damage, replacement documentation must be requested directly from the Manufacturer, quoting the code of this manual.

This manual reflects the state of the art at the time of commercialisation of the gear unit.

The Manufacturer reserves the right to modify, supplement and improve the manual, without the present publication being for that reason considered inadequate.

Particularly significant sections of the manual and important specifications are highlighted by symbols whose meanings are explained below

SYMBOLS:



DANGER - WARNING

This symbol indicates situations of danger, which if ignored, may result in serious injury to the operator.



CAUTION - ATTENTION

This symbol indicates the need to adopt specific precautions to avoid personal injury and damage, as well as economic damages.



IMPORTANT

This symbol indicates important technical information.



Instructions marked by these symbols and highlighted in yellow, apply exclusively to equipment complying with "ATEX" Directive 2014/34/EU.

The operations identified by these symbols must be executed by professionally qualified operators specially trained in the safety precautions required for working in potentially explosive atmospheres.

Failure to observe these instructions may result in serious safety and environmental risks.

1.2 PRODUCT IDENTIFICATION

The information identifying the product is shown on its nameplate. Gearmotors are equipped with two nameplates; one on the gear unit which bears the gear unit data, and one on the motor (electric or hydraulic), bearing the motor data.

The drawing below illustrates the layout of the data.

The gear unit's identifying code is explained in the Sales Catalogue. If the gear unit is supplied fitted with an electric motor (garmotor), all information regarding the motor is supplied in the motor manual.

Nameplate data

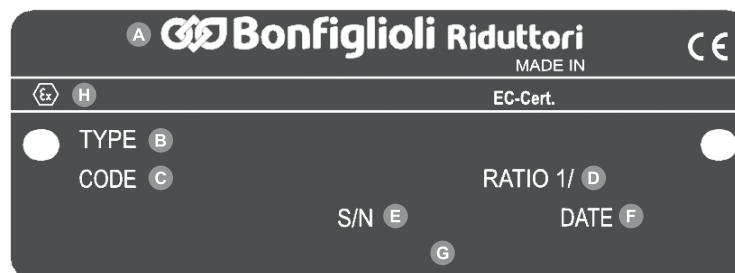

- | | |
|---------------------------------|---|
| A Manufacturer | E Serial number |
| B Product identification | F Date of manufacture |
| C Product code | G Client product code |
| D Reduction ratio | H Specific symbols of ATEX marking |

Readability of the nameplate

The nameplate and the information on it must be readable and, consequently must be cleaned from time to time.

Quote the nameplate data in all communications with the manufacturer, for example, when requesting spare parts, information and assistance.



1.3 GLOSSARY AND TERMINOLOGY

Some of the frequently occurring terms used in this manual are described below to unequivocally define their meaning.

Routine maintenance

The set of operations required to preserve the functionality and efficiency of the gear unit. These operations are usually scheduled by the Manufacturer, who defines the qualifications and tasks involved.

Reactive maintenance

The set of operations required to preserve the functionality and efficiency of the gear unit. These operations are not scheduled by the Manufacturer and must be carried out by an expert maintenance technician.

Expert maintenance technician

An authorised technician with the qualifications, skills and mechanical and electrical training required to do repairs and non-routine maintenance work on the gear unit.

Overhaul

An overhaul consists in the replacement of bearings and other mechanical components which have worn to such an extent as to compromise the operation of the gear unit. An overhaul also includes verification of the condition of all gear unit components (keys, seals, gaskets, vents, etc). If any such components are damaged they must be replaced and the reason for the damage identified.

1.4 REQUESTING TECHNICAL ASSISTANCE

For any technical service needs, contact the Manufacturer's sales network quoting the information indicated on the unit's nameplate, the approximate hours of service and the type of defect.

1.5 MANUFACTURER'S LIABILITY

The Manufacturer declines all liability in the event of:

- use of the gear unit in contravention of local safety at work legislation
- incorrect installation, disregard or incorrect application of the instructions provided in this manual
- incorrect or defective electrical/hydraulic power supply (garmotors)
- modifications or tampering
- work done on the unit by unqualified or unsuitable persons.

The safety of the gear unit also depends on scrupulous observance of the instructions given in this manual, and in particular:

- always operate the unit within its operating limits
- diligently observe the routine maintenance schedule
- only allow trained operators to inspect and service the unit
- only use original spare parts
- the configurations given in the gear unit catalogue are the only ones permitted
- do not attempt to use the unit in any other way
- the instructions given in this manual do not substitute but rather supplement the provisions of established safety legislation.



1.6 CONSIGNMENT CONDITIONS

Gear units are supplied by BONFIGLIOLI RIDUTTORI in the following conditions:

- Configured for installation in the mounting position specified in the purchase order.
- Not charged with lubricant and with internal components protected by a film of oil compatible with the recommended lubricant.
- All surfaces and mating parts are treated with rustproofing products.
- Mating surfaces are not painted while the unit's exterior is treated with a coat of grey water-based rustproofing primer (RAL 7042/C441). Application of a top coat is the responsibility of the Client.
- Tested to factory standards.
- Packaged suitably for the final destination.

2.0 TECHNICAL INFORMATION

2.1 DESCRIPTION OF THE GEAR UNIT

The gear unit, driven by an electric or hydraulic motor, has been designed and constructed for integration into an assembly of interlocking parts or mechanisms as part of a specific application. Depending on the requirements of the application, the gear unit can be supplied in a variety of motor executions and configurations. It is capable of satisfying a range of specific requirements in the mechanical, chemical, agricultural and food industries, etc.

BONFIGLIOLI RIDUTTORI supplies a range of accessories and optionals to make their products as versatile as possible. For further technical information and descriptions, refer to the corresponding Sales Catalogue.

The User is responsible for using the products recommended for installation and maintenance of BONFIGLIOLI RIDUTTORI gear units in an appropriate manner and in accordance with instructions.

SAFETY SPECIFICATIONS OF GEAR UNITS COMPLYING WITH DIRECTIVE 2014/34/EU



- unit selection must be made with a higher safety service factor
- use only synthetic lubricants (oil and grease)
- Use only fluoroelastomer seals.
- vent plugs with spring-loaded anti-intrusion valve
- oil plugs with aluminium washer
- oil seals with dust trap
- no metal moving parts external to the gear unit
- no plastic parts capable of building up an electrostatic charge, or, if present, duly shielded
- for installations in zones 21 and 22 the User must schedule and implement a regular cleaning programme for all surfaces and recesses to avoid dust build ups of more than 5 mm in depth.



2.2 CONFORMITY

All gearboxes or gearmotors (when supplied with motor) are designed as state of the art devices in compliance with the provisions of applicable Essential Health and Safety Requirements. All gearmotor motors conform to the provisions of the Low Voltage Directive 2006/95/EC and the Electromagnetic Compatibility Directive 2004/108/EC.



Furthermore, if specified for use in potentially explosive atmospheres, the gear units are designed and constructed to conform with the Essential Health and Safety Requirements (EHSR) of Annex II of the ATEX Directive 2014/34/EU and conform to the following classification:

- Equipment group: **II**.
- Category: Gas **2G** - Dust **2D**.
- Zone: Gas **1** - Dust **21**.
- Temperature class: **T4** for 2G and **135°C** for 2D.

2.3 OPERATING LIMITS AND CONDITIONS



Modification of the motor execution or mounting position is only permitted if previously authorised by BONFIGLIOLI RIDUTTORI's Technical Service. Failure to obtain said authorisation renders the ATEX certification null and void.

Ambient conditions

- Do not use the gear unit, if not explicitly intended for the purpose, in a potentially explosive atmosphere or where the use of explosion-proof equipment is specified.



The nameplate specifications regarding the maximum surface temperature, refer to readings taken in normal ambient and installation conditions. Even minimal variations to said conditions (e.g. smaller mounting cabinet) may have a significant effect on the unit's heat output.



- **Lighting**
If the unit is to be serviced in a poorly lit area, use additional lamps and ensure that the work is done in compliance with the safety requirements of established legislation.

2.4 ALLOWED TEMPERATURE LIMITS

Symbols	Description / Condition	Value (*)	
		Synthetic Oil	Mineral Oil
t_a	Ambient temperature		
$t_{au\ min}$	Minimum operating ambient temperature	-30°C	-10°C
$t_{au\ Max}$	Maximum operating ambient temperature	+50°C	+40°C
$t_{as\ min}$	Minimum storage ambient temperature	-40°C	-10°C
$t_{as\ Max}$	Maximum storage ambient temperature	+50°C	+50°C
t_s	Surface temperature		
$t_{s\ min}$	Minimum gearbox surface temperature starting with partial load (#)	-25°C	-10°C
$t_{sc\ min}$	Minimum gearbox surface temperature starting with full load	-10°C	-5°C
$t_{s\ Max}$	Maximum casing surface temperature during continuous operation (measured next to the gearbox input)	+100°C	+100°C (@)
t_o	Oil temperature		
$t_{o\ Max}$	Maximum oil temperature during continuous operation	+95°C	+95°C (@)

(*) = For further information about minimum and maximum values of different oil viscosity and for using hydraulic circuits refer to the table "Selection of the optimal oil viscosity" on the catalog available on www.bonfiglioli.com

(@) = Continuous operation it is not advised if t_s and t_o range is 80°C to 95 °C.

(#) = For full load start-up it is recommended to ramp-up and provide for greater absorption of the motor.
If needed, contact Bonfiglioli Technical Service. 



3.0 SAFETY INFORMATION

3.1 SAFETY STANDARDS

- Carefully read the instructions given in this manual and those posted directly on the gear unit, especially those regarding safety.
- Persons charged with working on the gear unit at any time in its service life must be trained specifically for the purpose with special abilities and experience in the area as well as being equipped with the appropriate tools and individual safety equipment (as per Legislative Decree 626/94). Failure to meet these requirements constitutes a risk to personal health and safety.
- The gear unit must only be used for the applications permitted by the Manufacturer. Improper use can result in risks to personal health and safety and economic damages.



The applications permitted by the Manufacturer are the industrial applications for which the gear units have been designed.

- Keep the gear unit at its maximum efficiency by following the routine maintenance schedule. Good maintenance ensures the unit's maximum performance, extended service life and continued compliance with safety regulations.
- When working on the unit in areas which are difficult to access or hazardous, ensure that adequate safety precautions have been taken for the operator and others in compliance with established legislation on health and safety at work.
- All maintenance, inspection and repairs must only be carried out by an expert maintenance technician fully familiar with the attendant hazards. It is therefore essential to implement operating procedures that address potential hazards and their prevention for the entire machine. The expert maintenance technician must always work with caution in observance of applicable safety standards.
- During operation wear only the apparel and safety equipment indicated in the User Instructions provided by the Manufacturer or stipulated by legislation on safety at work.
- Replace worn components with original spare parts. Use the lubricants (oil and grease) recommended by the Manufacturer.
- Do not dump polluting materials into the environment. Dispose of all such materials as stipulated by applicable legislation.
- After replacing lubricants clean the gear unit's surfaces and the walk-on surfaces around the work area.



If the gear unit is to be serviced in a potentially explosive atmosphere, the operator must first switch off power to the gear unit and ensure that it is out of service, as well as taking all necessary precautions against it being accidentally switched on again or its parts moving without warning. Furthermore, all additional environmental safety precautions must be taken (e.g. elimination of residual gas or dust, etc).

4.0 HANDLING AND TRANSPORT

4.1 PACKAGING

The standard packaging, if supplied and unless otherwise agreed, is not proofed against rainfall and is intended for shipping by ground and not sea, and for storage in areas which are under cover and not humid. The material can be stored in suitable conditions for a period of two years under cover at a temperature within the limits specified in the chapter “ALLOWED TEMPERATURE LIMITS” and at a relative humidity not in excess of 80%. Storage in all other conditions requires specific packaging.

The most frequent types of packaging are shown in the figures below.

- **Packaging on pallet with heat shrink film for ground shipping.**
- **Packaging in wooden crate for shipping by sea or air.**

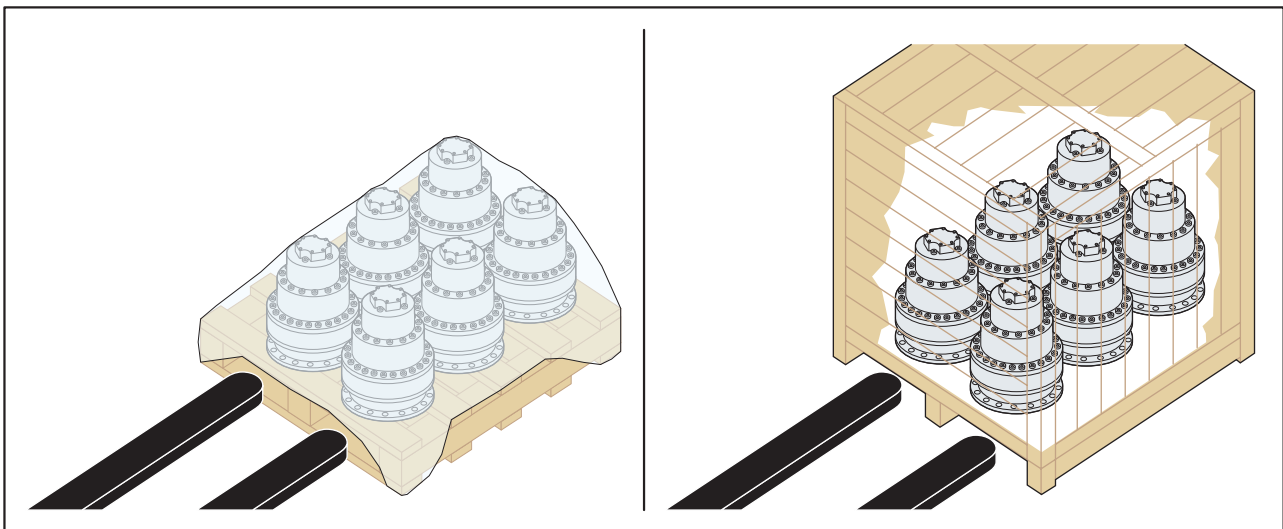

**On receipt of the gear unit, make sure the delivery corresponds to the purchase order and that it is not damaged or faulty in any way.
Report any nonconformity to your BONFIGLIOLI RIDUTTORI reseller.
Dispose of packaging materials as stipulated by applicable legislation.**

4.2 HANDLING INSTRUCTIONS

Handle packages as per the Manufacturer’s instructions and those marked on the packages themselves. Since the weight and shape of the packages may make manual handling unfeasible, special equipment must be used to avoid damage and injury. Persons authorised for this purpose must be trained and experienced in the work in question to avoid risks to themselves and others.



The person authorised to handle the product must take all necessary precautions to safeguard his safety and that of all other persons involved.



4.2.1 Moving the packages

- Prepare a suitable, delimited area with a level floor or surface for unloading the packages.
- Prepare the equipment required to handle the package. The lifting and handling equipment (e.g. crane or lift truck) must be of adequate capacity for the weight and size of the load, taking into account its attachment points and centre of gravity. If required, this information is indicated on the package itself. Harness heavy packages with chains, belts and steel ropes after checking that they are suitable for the weight of the load, which is always indicated.
- When handling the load keep it level to avoid tipping and instability.

4.2.2 Moving the equipment



All the following operations must be carried out with care and caution and without sudden movements.



When lifting, use accessories such as eyebolts, screw clamps, snap hooks, straps, ropes and hooks etc. which are certified and adequate for the load in question. The weight of the product to be lifted is given in the Sales Catalogue.

The following pages illustrate in detail the different attachment methods for the various product series, sizes and configurations described in this Manual. The most suitable solution for lifting and handling the product in safety is indicated for each.

Type of lifting	Manual	With mechanical equipment	
Symbol	M	A	B
Approximate weight	≤ 15 Kg	> 15 Kg	
Instruction	—	Recommended method for positioning	Recommended method for handling and positioning
Warning	—	The load may be unstable	The load may sway or oscillate
Solution	—	<p>Slide the lifting ring to align it with the load's centre of gravity as shown in the diagrams below</p> <p>Lock the ropes below the ring with a cable clamp or similar device so as to prevent them sliding, and lift the load</p> <p>Observe all precautions regarding the handling of loads</p>	<p>Stabilise the moving load by hand</p> <p>Observe all precautions regarding the handling of loads</p>

The load must not be allowed to sway by more than 15° in any direction when being lifted. If swaying exceeds this amount, stop and repeat the lifting operation as instructed.

Identify the attachment points for lifting the gear unit. Refer to the diagrams given below.

Horizontal positions

A 300 L ... 316 L , 310M L ... 316M L

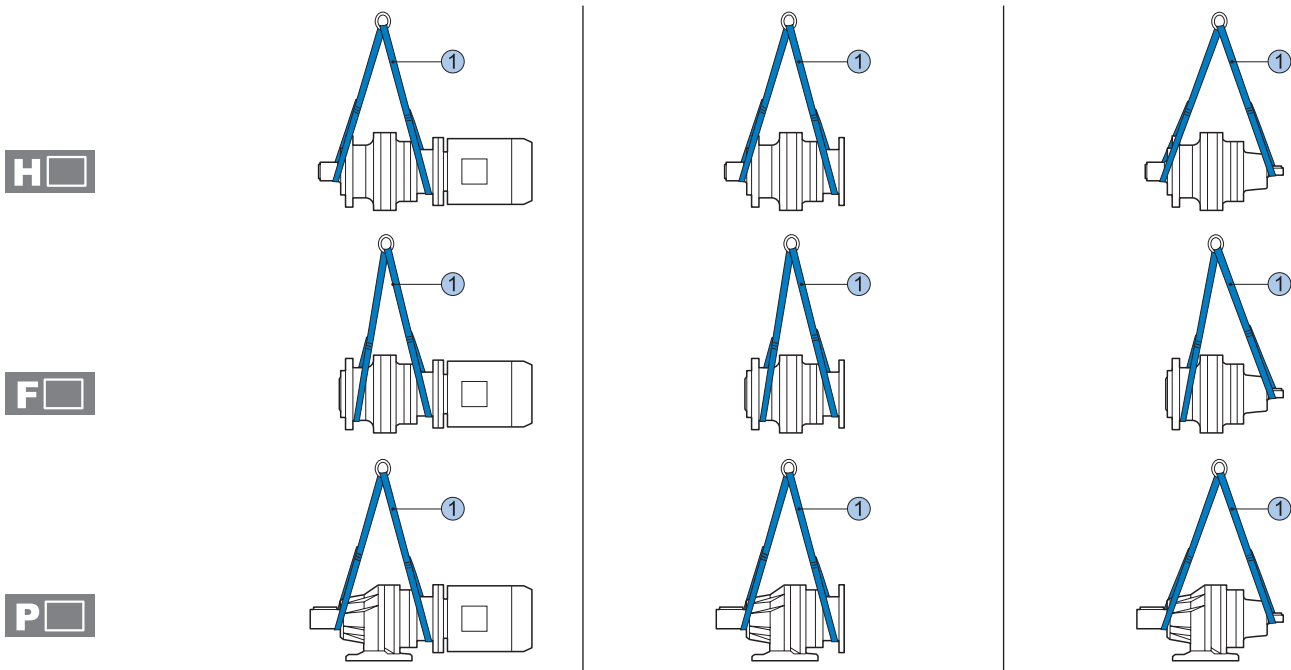

B 317 L ... 325 L , 317M L , 318M L

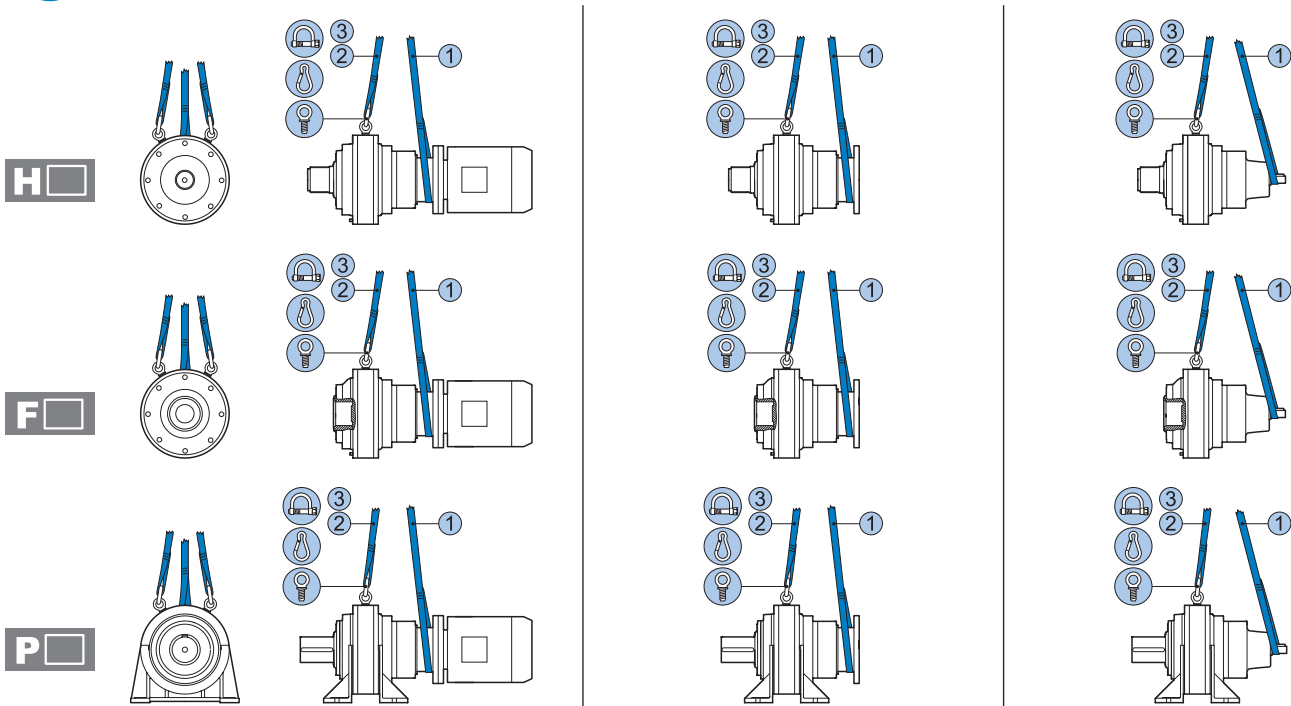

- ① Ring harness
- ② Rope and hooks
- ③ Open harness with eyelets
- Screw clamp (use with harness)
- Snap hook (use with rope)
- Eyebolt (already fitted on gear units 317-325 , 317M , 318M)

Maximum permissible tilt during handling: 15°

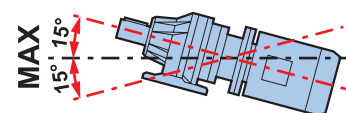



A **300 R ... 316 R , 310M R ... 316M R**

H

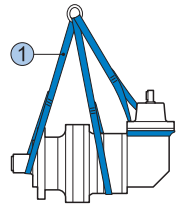
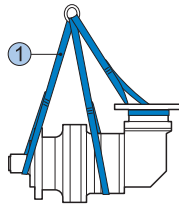
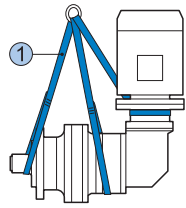

F

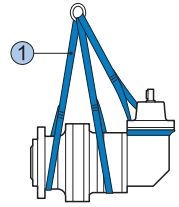
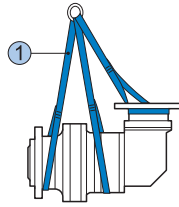
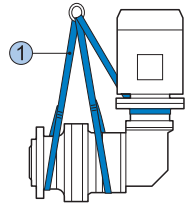

P

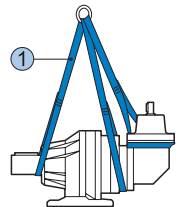
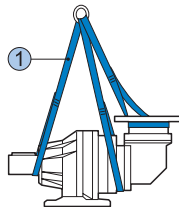
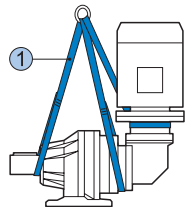

B **317 R ... 321 R , 317M R , 318M R**

H

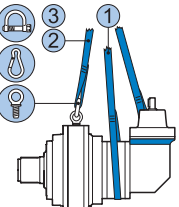
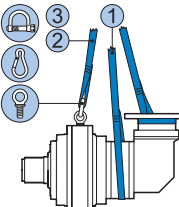
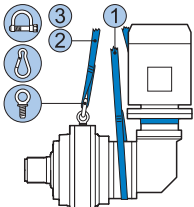
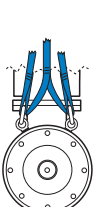

F

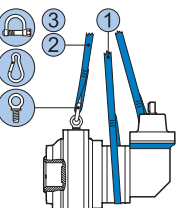
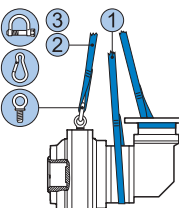
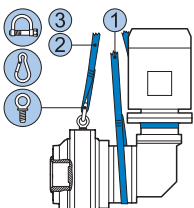
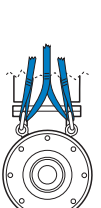

P

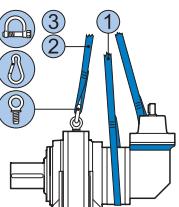
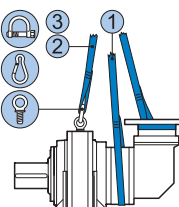
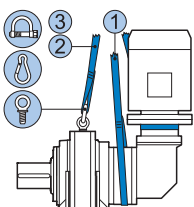
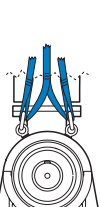

- ① Ring harness
- ② Rope and hooks
- ③ Open harness with eyelets

- Screw clamp (use with harness)
- Snap hook (use with rope)
- Eyebolt (already fitted on gear units 317-321 , 317M , 318M)

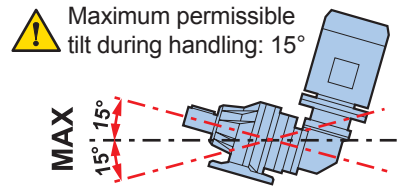



A 300 R ... 316 R , 310M R ... 316M R

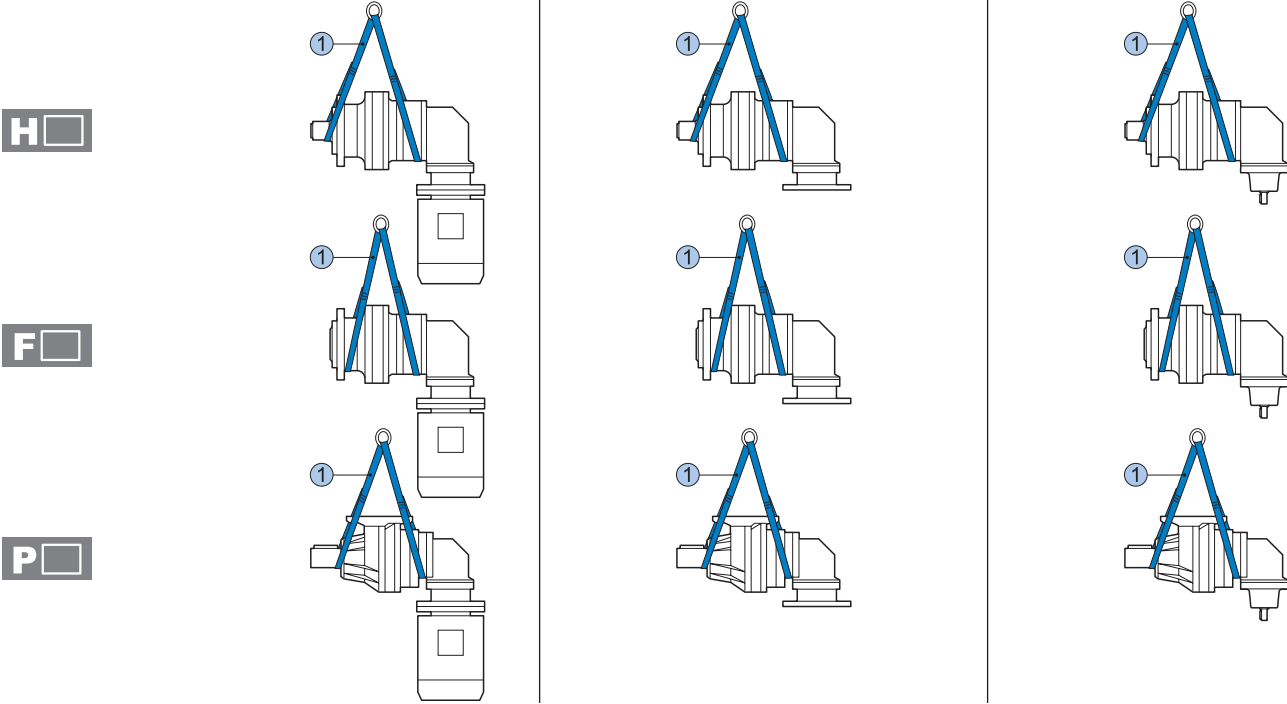

B 317 R ... 321 R , 317M R , 318M R

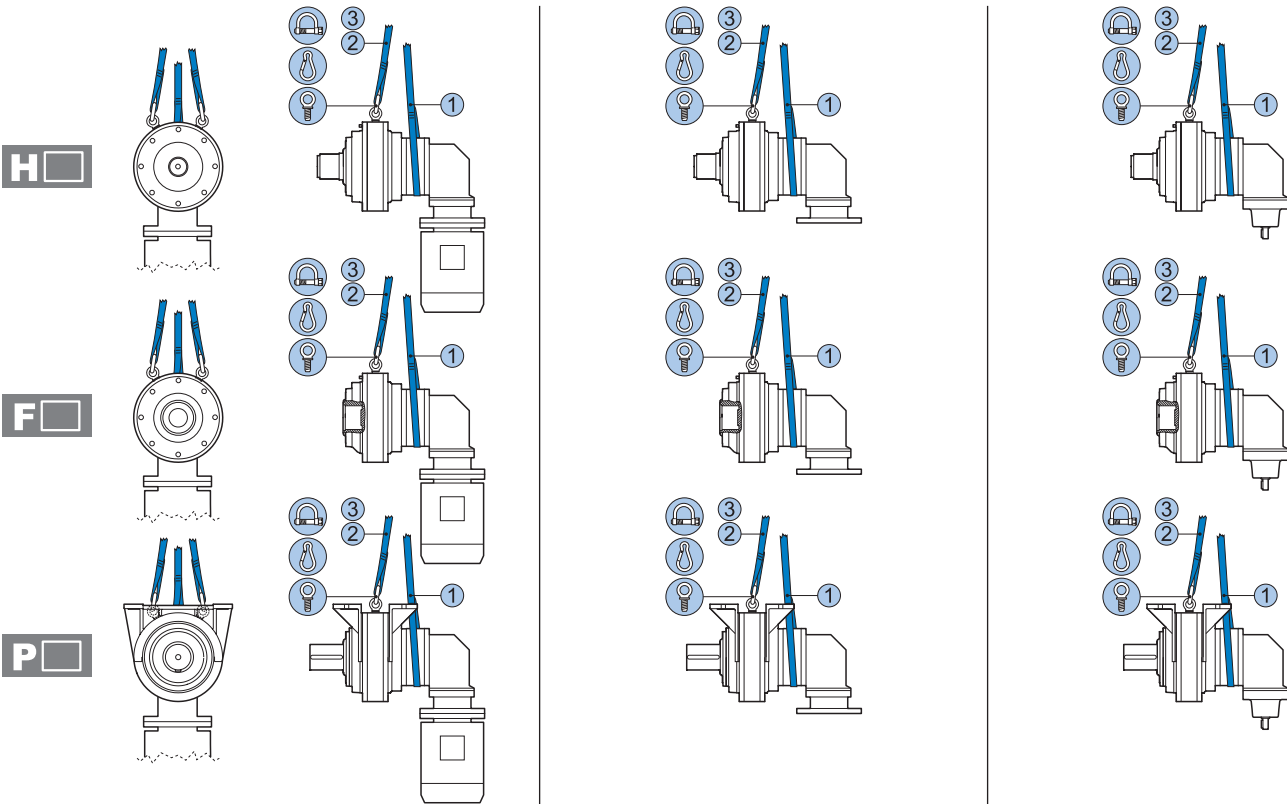

- ① Ring harness
- ② Rope and hooks
- ③ Open harness with eyelets

- Screw clamp (use with harness)
- Snap hook (use with rope)
- Eyebolt (already fitted on gear units 317-321 , 317M , 318M)

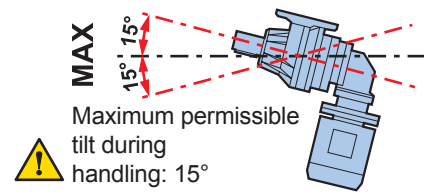



A **3V 00 ... 3V 16 , 3V 10M ... 3V 16M**

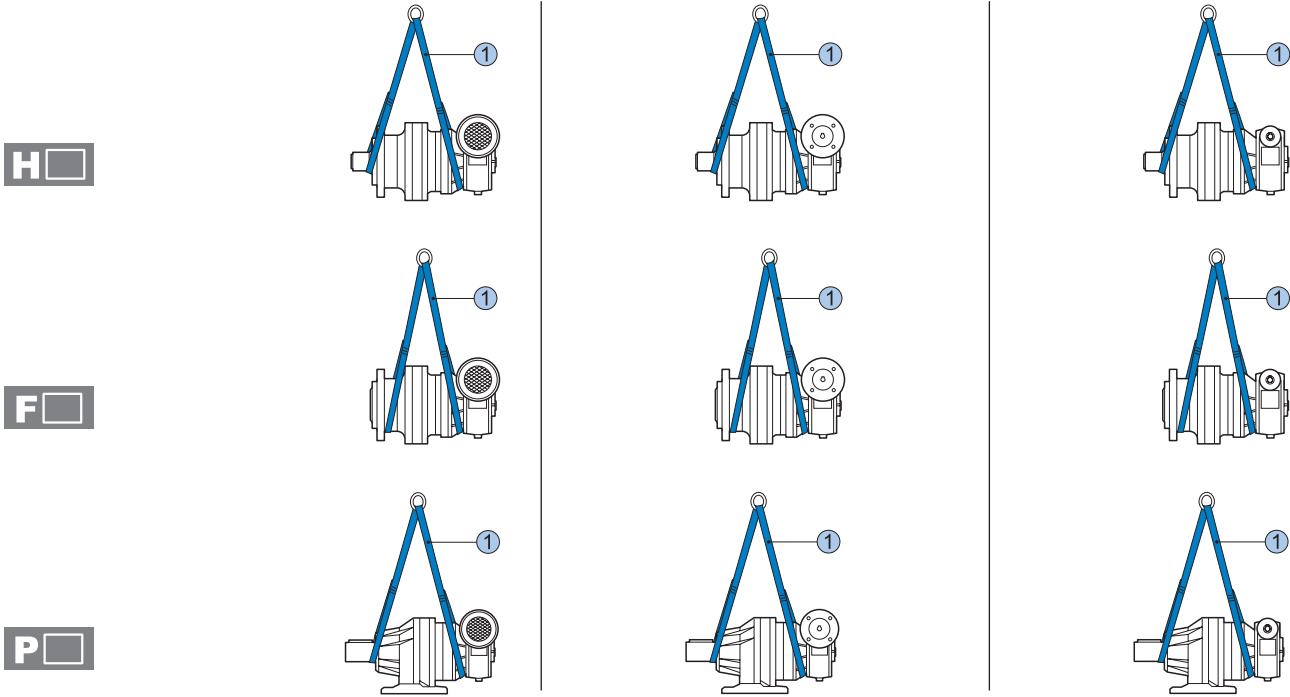

B **3V 17 ... 3V 21 , 3V 17M , 3V 18M**

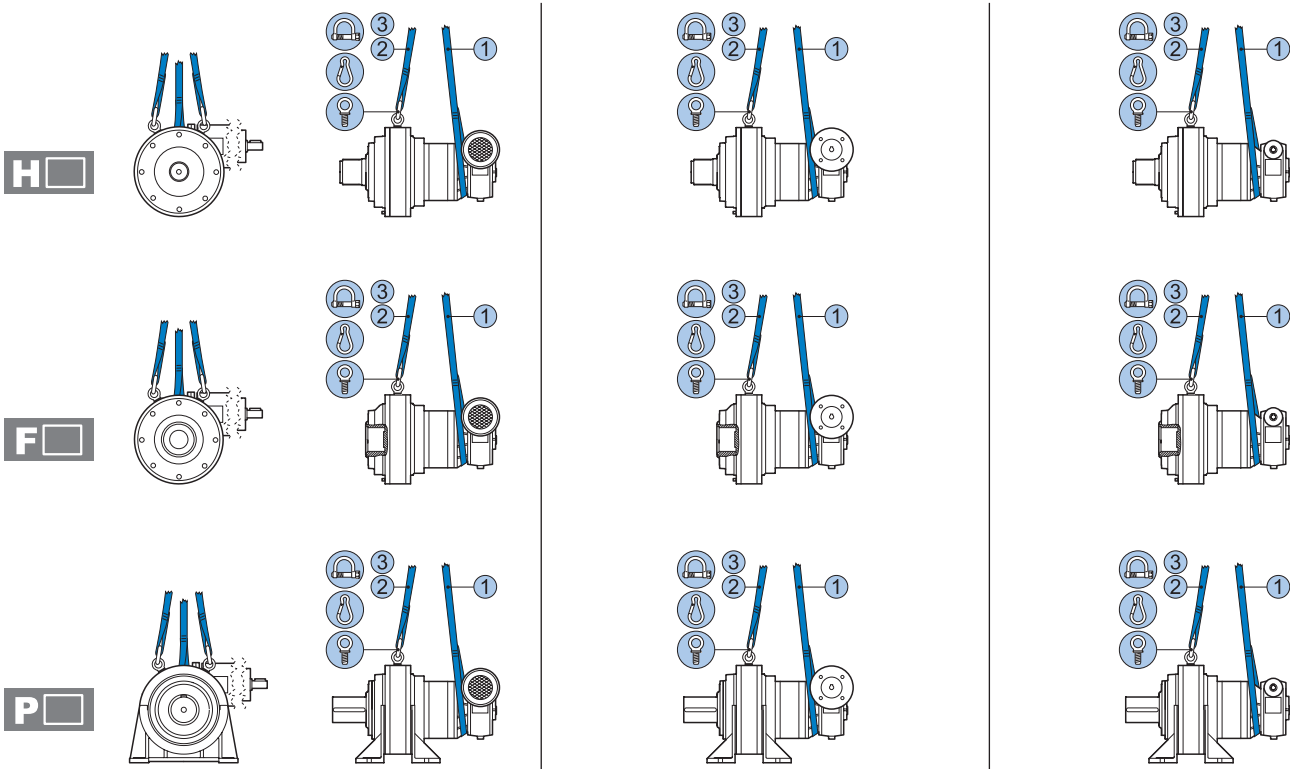

- ① Ring harness
- ② Rope and hooks
- ③ Open harness with eyelets

- Screw clamp (use with harness)
- Snap hook (use with rope)
- Eyebolt (already fitted on gear units 317-321 , 317M , 318M)

Maximum permissible tilt during handling: 15°

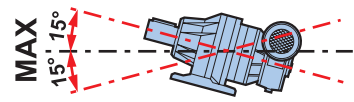



A **3A 00 ... 3A 07**

H

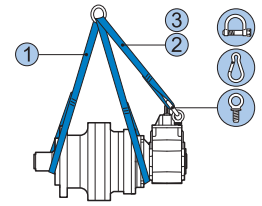
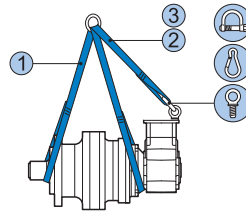
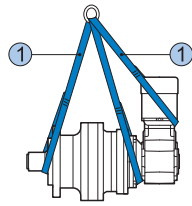

F

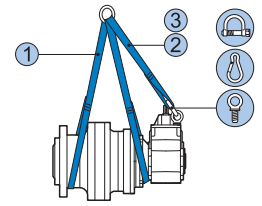
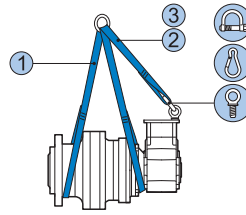
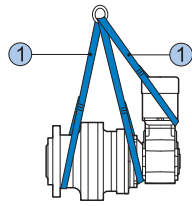

P

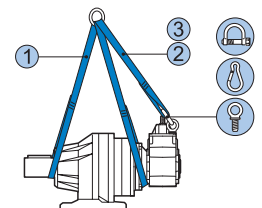
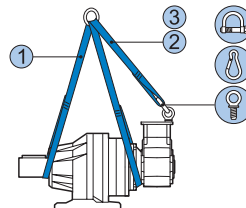
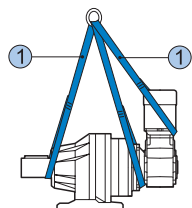

① Ring harness

② Rope and hooks

③ Open harness with eyelets

 Screw clamp (use with harness)

 Snap hook (use with rope)

 Eyebolt

 Maximum permissible tilt during handling: 15°

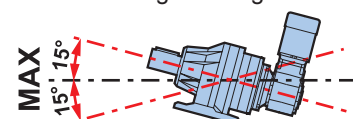



Vertical positions

B

300 L ... 325 L , 310M L ... 318M L

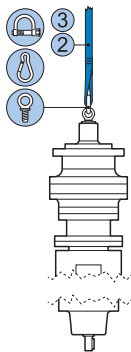
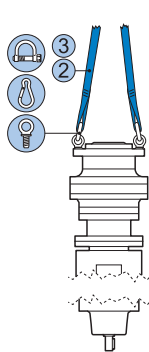
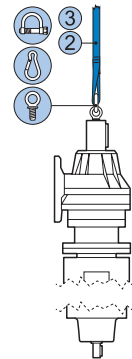
H **F** **P** **B**

300 R ... 321 R , 310M R ... 318M R

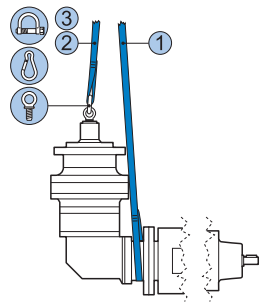
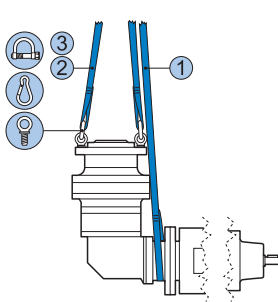
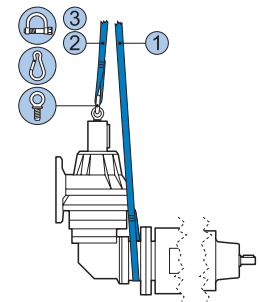
H **F** **P** **B**

3V 00 ... 3V 21 , 3V 10M ... 3V 18M

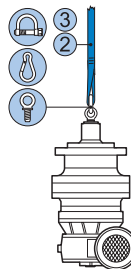
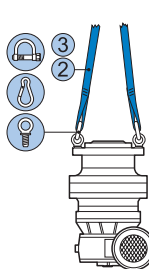
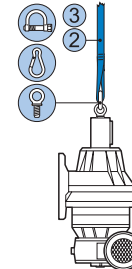
H **F** **P** **B**

3A 00 ... 3A 07

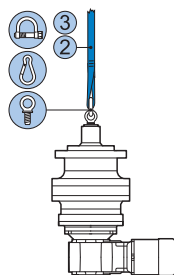
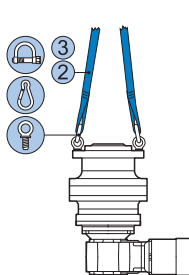
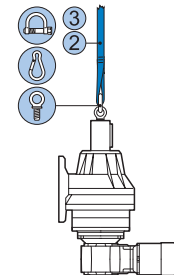
H **F** **P** 

- ① Ring harness
- ② Rope and hooks
- ③ Open harness with eyelets

- Screw clamp (use with harness)
- Snap hook (use with rope)
- Eyebolt (already fitted on gear units 317-325 , 317M , 318M)

Maximum permissible tilt during handling: 15°

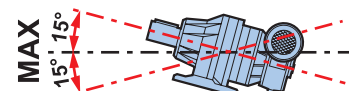

- Prepare the gear unit for lifting by attaching straps, hooks and screw clamps etc. to its attachment points. Alternatively, use a pallet to move the load. If using a crane, first lift the gear unit vertically out of its packaging.
- If using a lift truck or pallet truck, remove the packaging and insert the truck's forks at the indicated positions.
- First lift the load very slowly to check that it is stable.
- Move the gear unit to the unloading area and lower it gently into position, taking care not to tip it suddenly in transit.



If the gear unit is already equipped with an electric motor, do not use the eyebolts on the motor casing for lifting, unless expressly specified.

4.3 STORAGE

The following recommendations should be followed when storing the gear unit.

1. Do not store the unit in excessively humid conditions or where it is exposed to the weather (do not store outdoors).
2. Do not place the gear unit directly on the ground.
3. Place the gear unit on a stable base and make sure that it is not subject to accidental displacement.
4. Store the packaged gear unit (if allowed) in accordance with the instructions on the packaging itself.

If the gear unit is to be stored for more than 6 months, the following **additional** precautions must be taken:

5. Cover all machined external surfaces with a rustproofing product such as Shell Ensis or other product with similar properties and application range.
6. Fill the unit with lubricating oil and make sure the vent plug is positioned uppermost. Before putting the unit into service, the oil used for storage must be drained and replaced with the correct quantity of recommended operating lubricant.

PRECAUTIONS to be taken when returning the gear unit to service after storage.

The output shafts and external surfaces must be thoroughly cleaned of all rustproofing product, contaminants and other impurities (use a standard commercial solvent).
Do this outside the explosion hazard area.



The solvent must not touch the seal rings as this may damage them, causing them to leak



If the oil or protective material used during storage is not compatible with the synthetic oil used during the machine's operation, the interior of the unit must be thoroughly cleaned before filling with the operating oil.

The service life of the bearing grease is reduced if the unit is stored for more than 1 year.
The bearing grease must be synthetic.



LONG TERM STOCK

Here are reported the appropriate technical prescriptions to be performed to ensure the service LONG TERM STOCK of the unit for a maximum stock up to 2 years.

The service can be extended for another two years before its expiration. To extend this service, contact the Bonfiglioli service center available on the company website.

Conditions of unit's receipt

According to the unit's size, the customer receives the gear unit or gearmotor with the LONG TERM STOCK option inside one of the following two suitable containers:

1) **BBOX**: an adhesive label "OPEN ONLY BEFORE THE INSTALLATION" is applied on each of the 4 outer walls of the box.

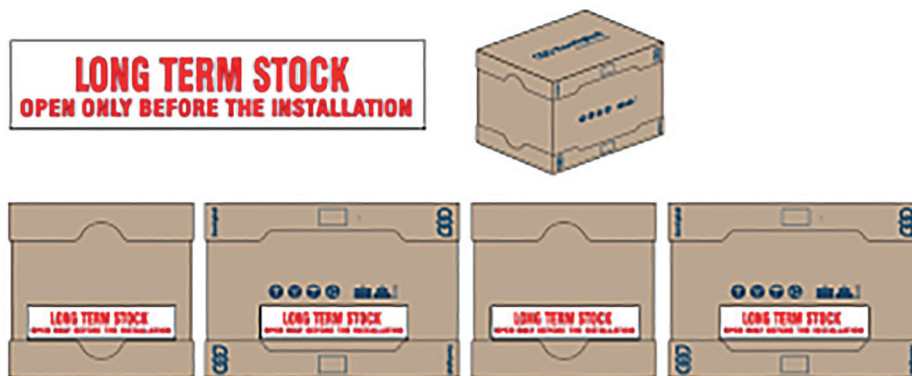

2) **WOODEN CRATE**: the words "LONG TERM STOCK - OPEN ONLY BEFORE THE INSTALLATION" are sprayed on each of the 4 outer walls of the crate.



The container has to be stocked and must not be opened by customer before the need to commission the unit.

Internally to the container the unit is packed inside a VpCI (Vapor phase Corrosion Inhibitor) bag:



The unit packed inside a VpCI is identified by a specific adhesive label “**WARNING LONG TERM STOCK**” placed on the external surface of the VpCI bag.



Internally to the VpCI bag, a tag “**WARNING_LONG TERM STOCK**”, tied to a lanyard ,will be visible on the surface of the gearbox:



The gearbox nameplate will be a conventional nameplate with the addition of the LONG TERM STOCK option in the description.

Proper Long Term Stock activities

- Do not store the container in excessively humid conditions or where it is exposed to the weather (do not store outdoors)
- Do not place the container directly on the ground. Place the container on a pallet
- Do not place the container in conditions of excessive temperature changes for can cause condensation to form inside the gearbox and from the accessories installed
- Store the container in according to these environmental conditions: ambient temperature from min -10°C to max +40°C, dry environment and free from direct sunlight
- The container has to be stocked and must not be opened before the commission of the unit

After 2 years of stock, the unit with the LONG TERM STOCK option needs to be checked in a Bonfiglioli assistance center. In case of a product that hasn't been properly preserved, an offer by Bonfiglioli will be issued for a complete restore.

Subsequently with the recovery activity successfully concluded, the unit with the LONG TERM STOCK option can be stored again in the customer's warehouse for a maximum of other 24 months according to the above precautions.



5.0 INSTALLATION

5.1 INSTALLING THE GEAR UNIT



The entire installation process must be planned as early as the general design phase of the machine. The person authorised to do the work must, if necessary, set out a safety plan to protect the health and safety of all persons directly involved and apply all applicable legislation.

1. Carefully remove all packaging and protective product residue from the gear unit. Pay particular attention to the mating surfaces.
2. Check that the data on the nameplate correspond to those specified in the purchase order.
3. Ensure that the structure to which the gear unit is to be mounted is sufficiently robust and rigid to support its weight and operating stresses.
4. Check that the machine to which the gear unit is to be installed is switched off and cannot be accidentally switched on again.
5. Make sure all mating surfaces are flat.
6. Make sure the shaft/shaft or shaft/ bore are perfectly aligned for coupling.
7. Fit suitable guards to protect against the gear unit's external moving parts.
8. If the work environment is corrosive for the gear unit or any of its parts, follow the special precautions required for aggressive environments. In this case, contact the BONFIGLIOLI RIDUTTORI sales service.
9. We recommend applying a protective paste to all gear unit/motor mating surfaces and other parts (Klüberpaste 46 MR 401 or other product with similar properties and application range) to ensure optimal coupling and protection against fretting corrosion.
10. In the case of outdoor installations fitted with an electric motor, protect the latter from direct sunlight and the weather by means of guards or a casing. Also make sure that the assembly is properly ventilated.

5.1.1 Flanged execution

Machine the coupling counterflange on the machine to which the gear unit is to be installed. The flanges must be plane and machined with machine tools. Connect the output shaft to the driven component as indicated in the drawings below.

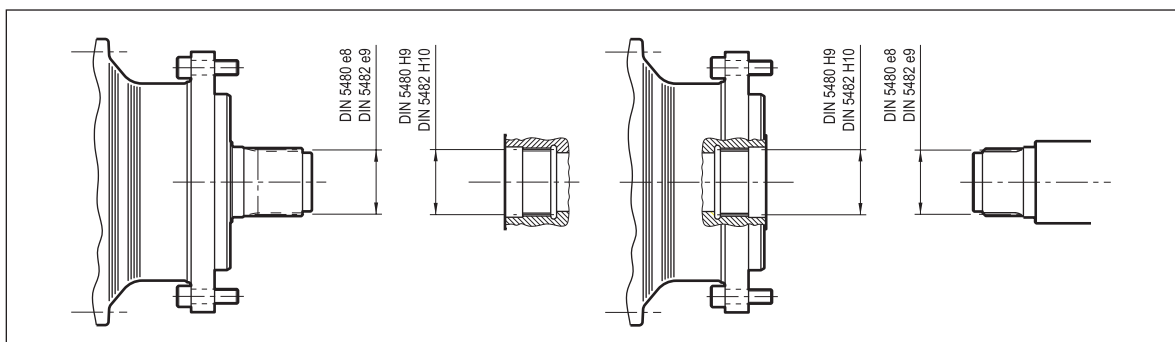

Recommended tolerances

Loose coupling		Solid shaft	
Hollow shaft	Coupling with interference	Hollow shaft	Coupling with interference
$\varnothing d h6$	$\varnothing D G7$	$\varnothing d h6$	$\varnothing D P7$
$\varnothing d k6$	$\varnothing D F7$	$\varnothing d k6$	$\varnothing D M7$
$\varnothing d m6$	$\varnothing D F7$	$\varnothing d m6$	$\varnothing D K7$
$\varnothing d r6$	$\varnothing D E7$	$\varnothing d r6$	$\varnothing D H7$

For machining the spigot on the driven machine, refer to the diagrams below:

300...307 gear units - male output shaft motor execution

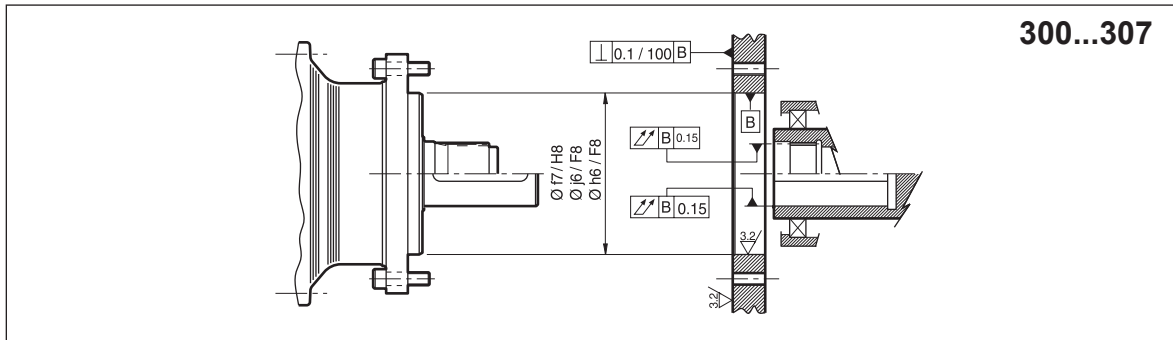

309...321 , 310M...318M gear units - male output shaft motor execution

With $R > 60\% R_{n2}$, the output shaft inflection can be higher than 0.5 mm, measured at the end of the shaft. If the application requires a lower deformation, it is recommended to use both centering on the gear units.

If the gear unit is instead required to transmit high torque or is subject to heavy shock loads and inversions in the direction of rotation, the counterflange must be drilled to accept the spigots.

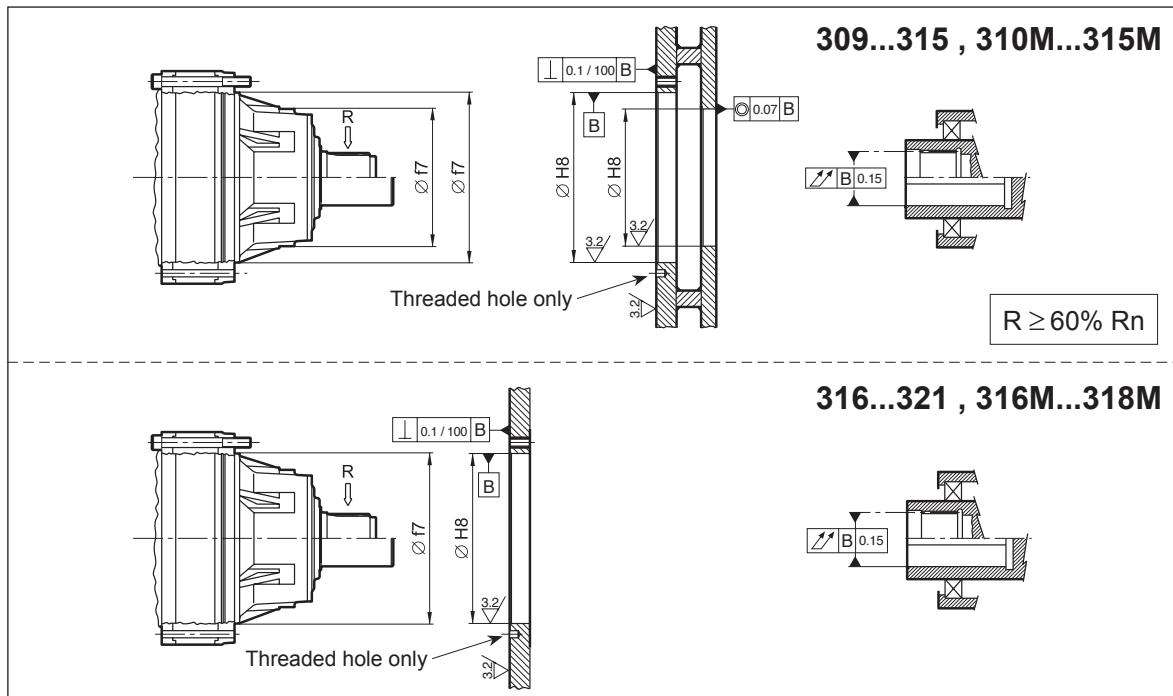



Mounting with hollow splined shaft

Ensure that the gear unit and driven shaft are aligned and that the latter is not subject to flexing during operation. See diagram below:

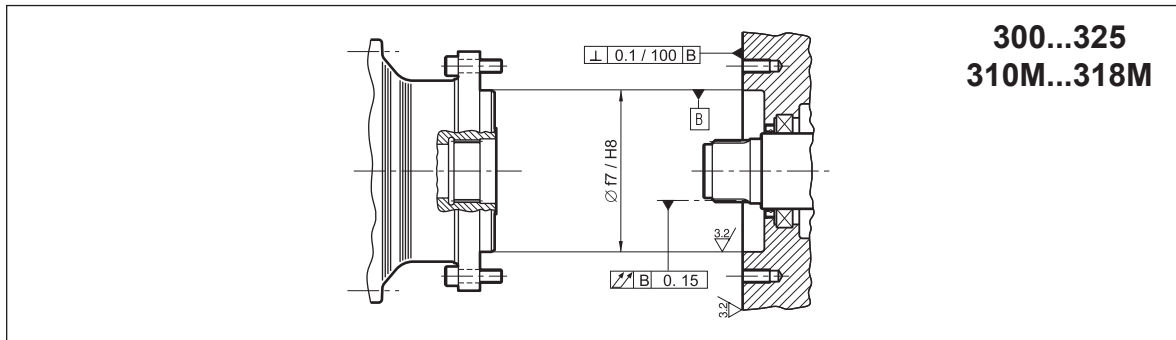

Flanged gear unit mounting bolts

	300	301	303	304	305	306	307	309	310 310M	311 311M	313 313M	314 314M	315 315M	316 316M	317 317M	318 318M	319	321	323	325
Bolt	M10	M10	M12	M12	M12	M14	M16	M16	M16	M16	M16	M20	M20	M20	M30	M27	M30	M30	M42	M42
Quantity	8	8	10	10	10	12	10	12	15	24	30	20	20	30	24	32	30	36	36	36
Class	12.9	12.9	12.9	12.9	12.9	12.9	12.9	12.9	12.9	12.9	12.9	12.9	12.9	12.9	12.9	12.9	12.9	12.9	12.9	12.9
Tightening torque [Nm]	85	85	145	145	145	230	350	350	350	350	350	690	690	690	2350	1750	1750	1750	6750	6750

For applications in areas that do not permit/allow this class, please contact the Technical Service of the Manufacturer.

Customer's shaft axial mounting version FDK (300-310 , 310M) and FZP (311-325 , 311M-318M)

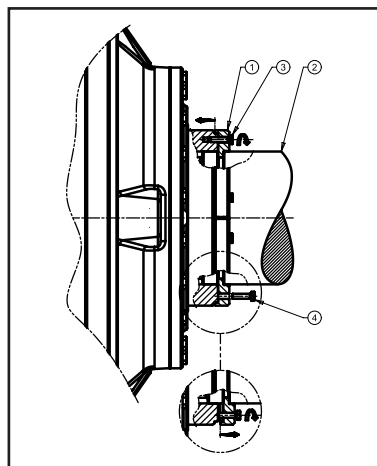

VERSION	SIZE	BOLTS x4
FDK	300	M4
	301	
	303 / 304 / 305	M6
	306	
	307	
	309	M8
FZP	310 / 310M	
	311 / 311M	
	313 / 313M	
	314 / 315 / 314M / 315M	M8
	316 / 316M	
	317 / 317M	
	318 / 318M	
	319	M10
	321	M12
	323	
325	M20	

- Remove the two axial mounting half-rings (1) from the gear unit
- Make the customer shaft (2) as indicated in the technical catalogue (see www.bonfiglioli.com for up-to-date version)
- Properly lubricate both the shaft and its housing, then connect the shaft to the gear unit
- Apply the two axial mounting half-rings, by placing them in the respective circumferential housing on the shaft
- Assemble the fixing screws (3) by screwing them gradually and diametrically, applying the tightening torque indicated in the "Dimensions" section of the technical catalogue (see www.bonfiglioli.com for up-to-date version)
- To remove the shaft, loosen all the screws. Procure additional 4 screws (as shown in the table, not provided with the gear unit) and screw them in the threaded holes on the two half-rings, react on the gear unit up to the release of the shaft.

5.1.2 Foot mounting

Foot-mounted motor execution

Gear units of this type must be mounted on a suitably rigid base, machined flat with a planarity error margin of no more than 0.2 mm / 100 mm.

See diagram below:

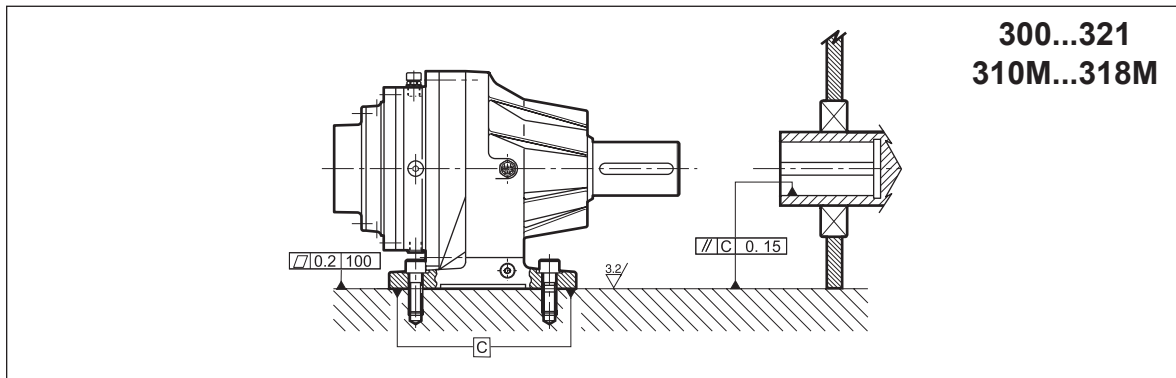

Foot-mounted gear unit mounting bolts

	300	301	303	304	305	306	307	309	310 310M	311 311M	313 313M	314 314M	315 315M	316 316M	317 317M	318 318M	319	321
Bolt	M16	M16	M16	M16	M16	M20	M24	M24	M24	M30	M30	M30	M30	M36	M30	M36	M48	M48
Quantity	4	4	4	4	4	4	4	4	4	4	4	8	8	8	8	8	4	8
Class	8.8	8.8	8.8	8.8	8.8	8.8	8.8	8.8	8.8	8.8	8.8	8.8	8.8	8.8	8.8	8.8	8.8	8.8
Tightening torque [Nm]	200	200	200	200	200	400	700	700	700	1400	1400	1400	1400	2500	1400	2500	6000	6000

5.1.3 Shaft mounting

Mount the torque arm with bolts of class and torque as indicated in the table below:

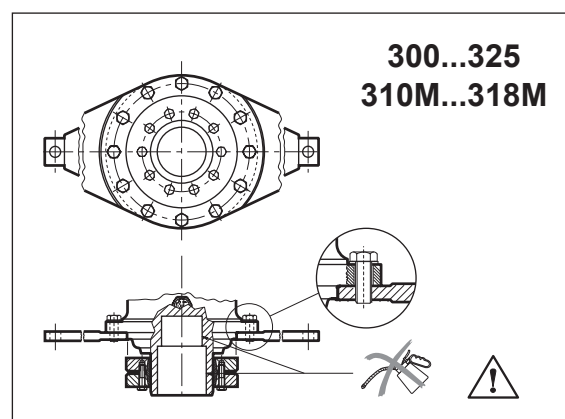
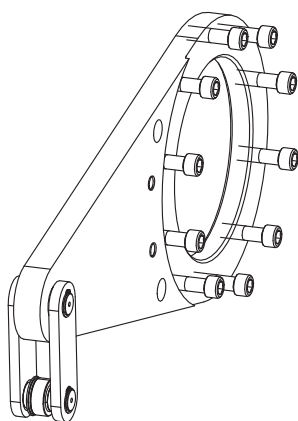

	300	301	303	304	305	306	307	309	310 310M	311 311M	313 313M	314 314M	315 315M	316 316M	317 317M	318 318M	319	321	323	325
Bolt	M10	M10	M12	M12	M12	M14	M16	M16	M16	M16	M16	M20	M20	M20	M30	M27	M30	M30	M42	M42
Quantity	8	8	10	10	10	12	10	12	15	24	30	20	20	30	24	32	30	36	36	36
Class	12.9	12.9	12.9	12.9	12.9	12.9	12.9	12.9	12.9	12.9	12.9	12.9	12.9	12.9	12.9	12.9	12.9	12.9	12.9	12.9
Tightening torque [Nm]	85	85	145	145	145	230	350	350	350	350	350	690	690	690	2350	1750	1750	1750	6750	6750



Clean and degrease both the internal coupling surface of the gear unit shaft and the external coupling surface of the machine's driven shaft.
Mount the shrink disk to the gear unit's shaft after lightly lubricating its entire outer surface.

Mounting sequence for shrink discs with gear units sizes 300-313 , 310M-313M

- Snug down a first set of 3 bolts located at the corners of an equilateral triangle (for example: bolts in pos. 1-5-9 of the diagram below). Fit the gear unit to the driven shaft.
- Tighten down the bolts (following the triangular pattern) in a circular direction, repeating the operation several times until all bolts are tightened to the torque specified in table 2, in accordance with the type of disk/gear unit.

Mounting sequence for shrink discs with gear units sizes 314-325 , 314M-318M

- Tighten 4 screws equally spaced at 50% of the value of the tightening torque indicated in table 2, crosswise. (example: screws 1-7-4-10)
- Tighten 4 screws equally spaced at 100% of the value of the tightening torque indicated in table 2, crosswise. (example: screws 2-8-5-11)
- Tighten all the screws continuously up to the point that, by applying the tightening torque indicated in table 2, these no longer have any movement.
- Check the effective alignment of the inner and outer ring of the coupling.



Do not use molybdenum bisulphide or any other grease, which could reduce the friction of the mating surfaces and affect the performance of the shrink disk.

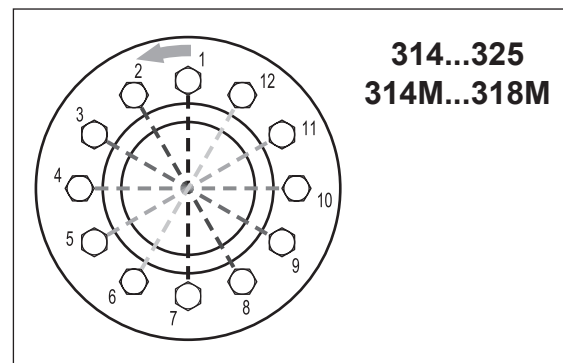
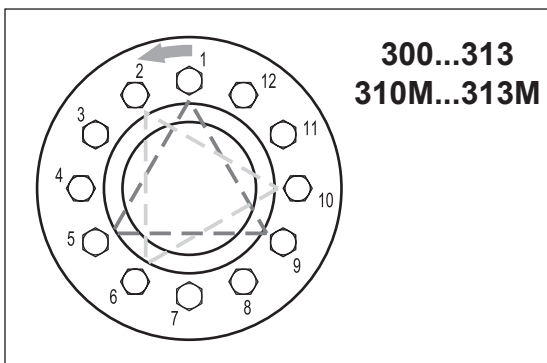

Disassembly sequence

Gradually unlock the fixing screws in a circular direction. Do not completely remove the screws to avoid violent separation of the coupling rings.

If it is still not possible to disassemble the gearbox from the customer shaft, use the holes described here to introduce oil under pressure (see the following image).

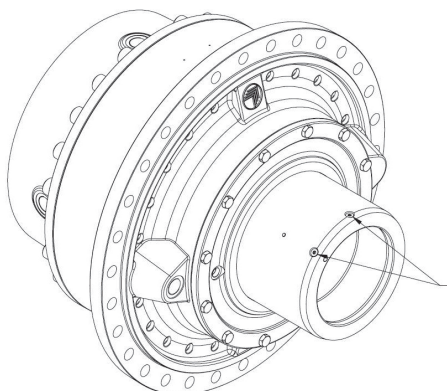

N.2 HOLES 1/8" BSP (316 - 319) AND 1/4" BSP (323 - 325)
FOR THE INTRODUCTION OF PRESSURIZED OIL
TO FACILITATE REMOVING THE CUSTOMER SHAFT



Shrink disk mounting bolts

(2)

	300	301	303	304	305	306	307	309	310	311	313	314	315	316	317	318	319	321	323	325
Bolt	M6	M6	M8	M8	M8	M10	M10	M16	M16	M16	M16	M20	M20	M20	M20	M20	M24	M27	M30	M30
Quantity	8	10	12	12	12	9	12	8	8	10	10	15	15	15	16	20	18	16	21	24
Class	10.9	10.9	10.9	10.9	10.9	10.9	10.9	10.9	10.9	10.9	10.9	10.9	10.9	12.9	12.9	12.9	10.9	10.9	10.9	10.9
Tightening torque [Nm]	12	12	30	30	30	58	58	250	250	250	250	490	490	570	570	570	840	1250	1640	1640

Proceed with the installation as follows:

1. Place the gear unit in the vicinity of the installation area.
2. Mount the gear unit and secure it to the structure at the points provided. The gear unit should be secured to the structure at all the mounting points (bores) on the mount provided (feet or flange).
3. Tighten down the mounting bolts and check that the service plugs are screwed down to the torques given in the chart.





Locate the closed oil plug used during shipping and replace it with the vent plug supplied in the shipment.

5.1.4 Installing accessories on solid input and output shafts

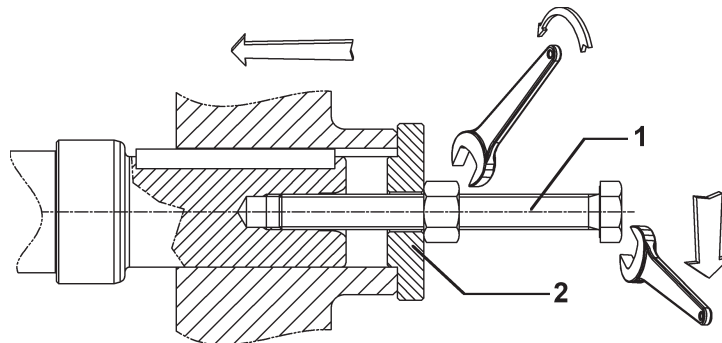

Do not use hammers or other tools that might damage the gear unit's shafts or bearings when mounting external parts. Instead, proceed as illustrated in the diagram below:



Bolt (1) and spacer (2) are not included in the consignment.

To minimise the loads on the shaft bearings, when mounting transmission mechanisms with asymmetrical hubs use the configuration shown in diagram **(A)** below:

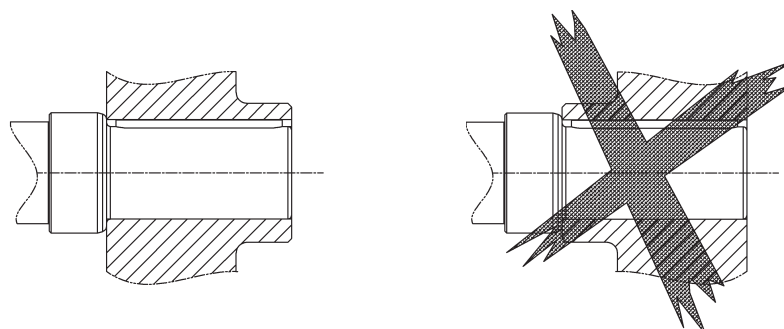



Mounting pulleys

Clean all parts before installing them. When installing belt drive pulleys, the shafts must be parallel with their pulleys aligned.

Do not over tension the drive belt as this can damage the bearings.

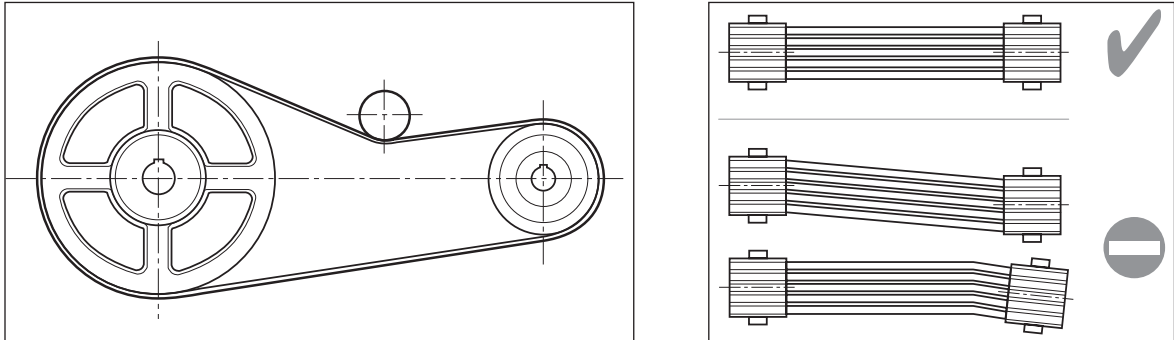

Shaft end: threads

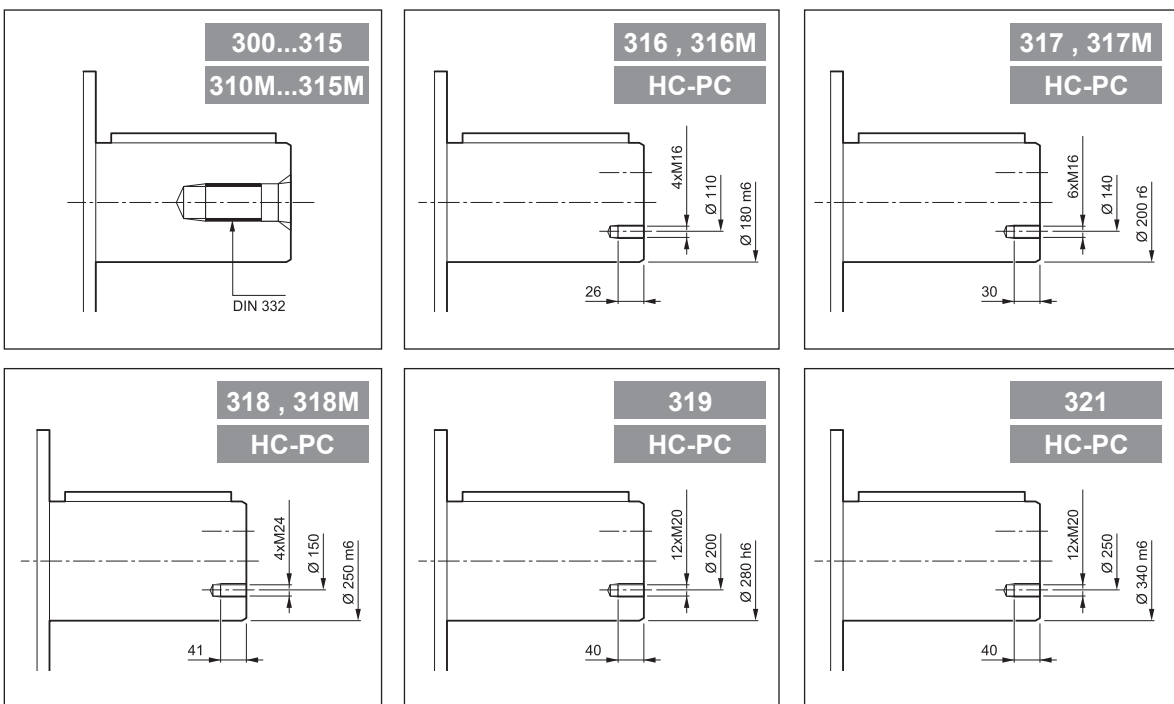

	300	301	303	304	305	306	307	309	310 310M	311 311M	313 313M	314 314M	315 315M	316 316M	317 317M	318 318M	319	321
MC	M12	M12	M20	M20	M20	M20	M20	—	—	—	—	—	—	—	—	—	—	—
HC	M16	M16	M20	M20	M20	M20	M20	M24	M24	M24	M24	M24	M24	4xM16	6xM16	4xM24	12xM20	12xM20
PC	M12	M16	M20	M20	M20	M20	M20	M24	M24	M24	M24	M24	M24	4xM16	6xM16	4xM24	12xM20	12xM20
VK	—	—	M20	M20	M20	M24	M24	M24	M24	M24	M30	M30	M30	—	—	—	—	—

Installing accessories on splined shafts



Do not use hammers or other tools that might damage the gear unit's shafts or bearings when mounting external parts. Instead, proceed as illustrated in the diagram below:

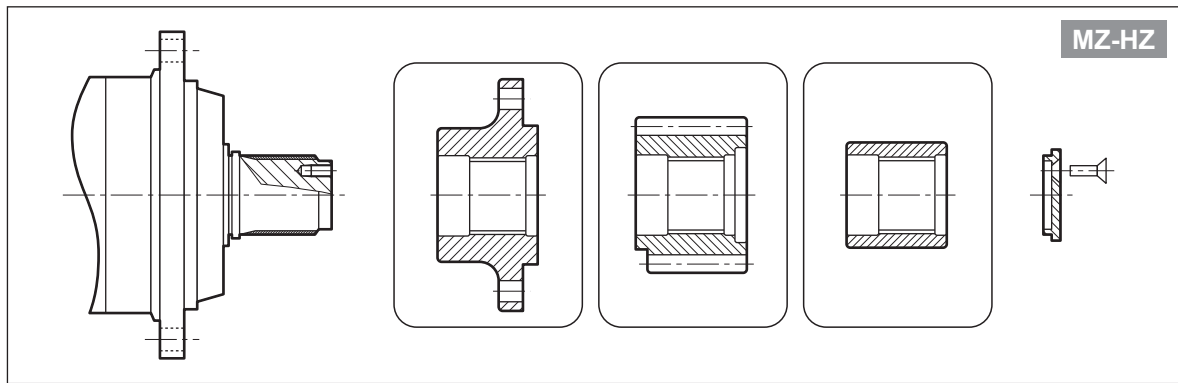

Always use the stop end plate supplied with the gear unit.

5.1.5 Installation of Gear units supplied without motor connection

To prevent disassembly, place the gear unit in a vertical position before removing the protective cover "A".

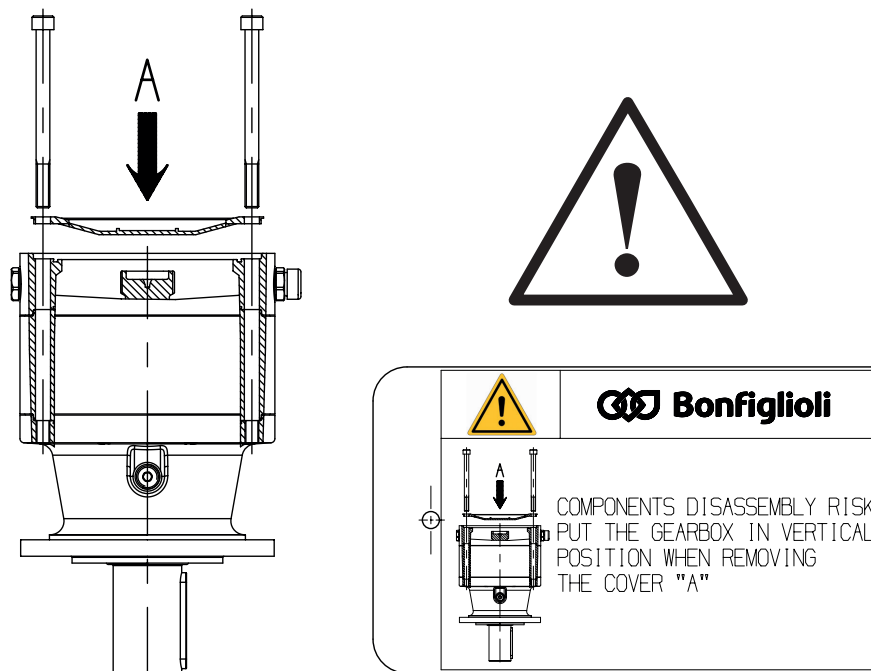

5.2 INSTALLING THE ELECTRIC MOTOR

Further to all the precautions indicated above, when installing a standard IEC 72-1 electric motor, the following precautions must also be observed:

- Do not force the coupling and do not use inappropriate tools during assembly. Take care not to damage the flat/cylindrical coupling surfaces.
- Do not force the rotary coupling mechanisms with heavy overhung or thrust loads.
- To facilitate assembly, use a lubricating synthetic oil paste such as Klüberpaste 46 MR 401 or another product with similar properties and application range.

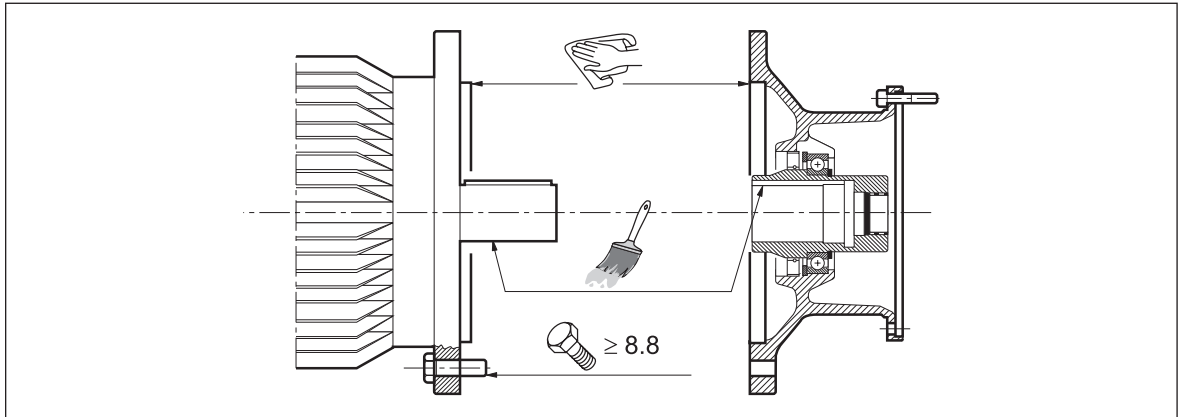

• Provided all the above checks have been performed and passed and all other instructions in this manual have been strictly observed, an electric motor with ATEX rating equal to or greater than that of the gear unit may be installed, thus forming a gearmotor which itself complies with the provisions of Directive 2014/34/EU.



If, instead, the assembly of the motor to the gear unit requires actions other than those prescribed in this Manual or one or more of the manual's prescriptions have not been satisfied, the User shall be responsible for analysing the risks attendant on this particular motor/gear unit combination. The risk analysis is in any case obligatory if the motor is powered by an inverter.

Only in this way, and subject to self-certification by the assembler, shall the assembly, including the gear unit itself, be compliant with the requirements of Directive 2014/34/EU.

5.3 INSTALLING THE HYDRAULIC MOTOR



Connecting the hydraulic motor

Remove the protective plug.

Hydraulic motor mountings are available in two versions:

a) Version with O-ring oil gasket between motor flange and gear unit.

In this case, mount the gasket to ensure an oil tight seal between the motor and gear unit, taking care to fit it correctly in its seat without damaging it.

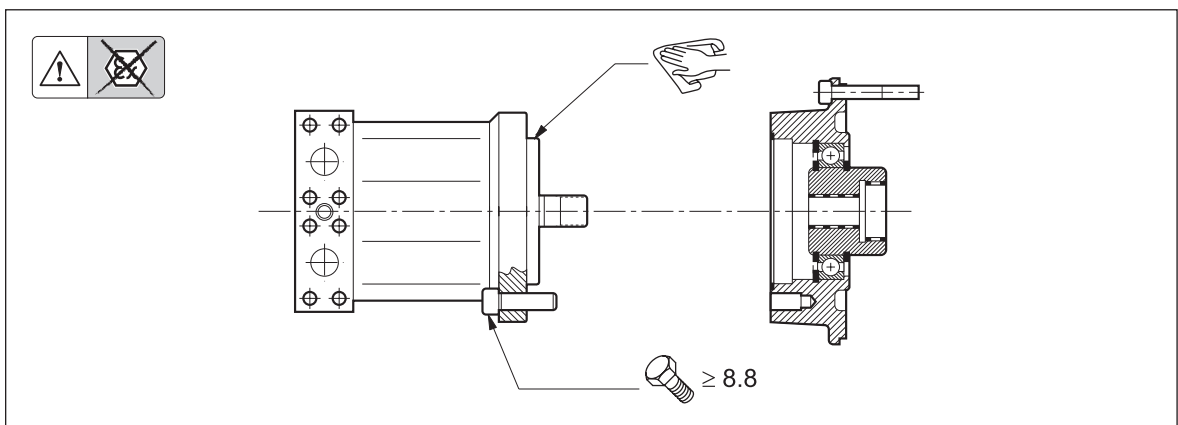

b) Version with gasket already mounted to the coupling.
 In this case no special intervention is required to ensure an oil tight seal since this is already provided by the motor coupling. Merely smear the motor shaft with grease.
 In both cases, clean the spigot and the coupling where the motor is to be fitted, fit the motor and tighten down the flange mounting bolts.
 Always use bolts rated to at least class 8.8.

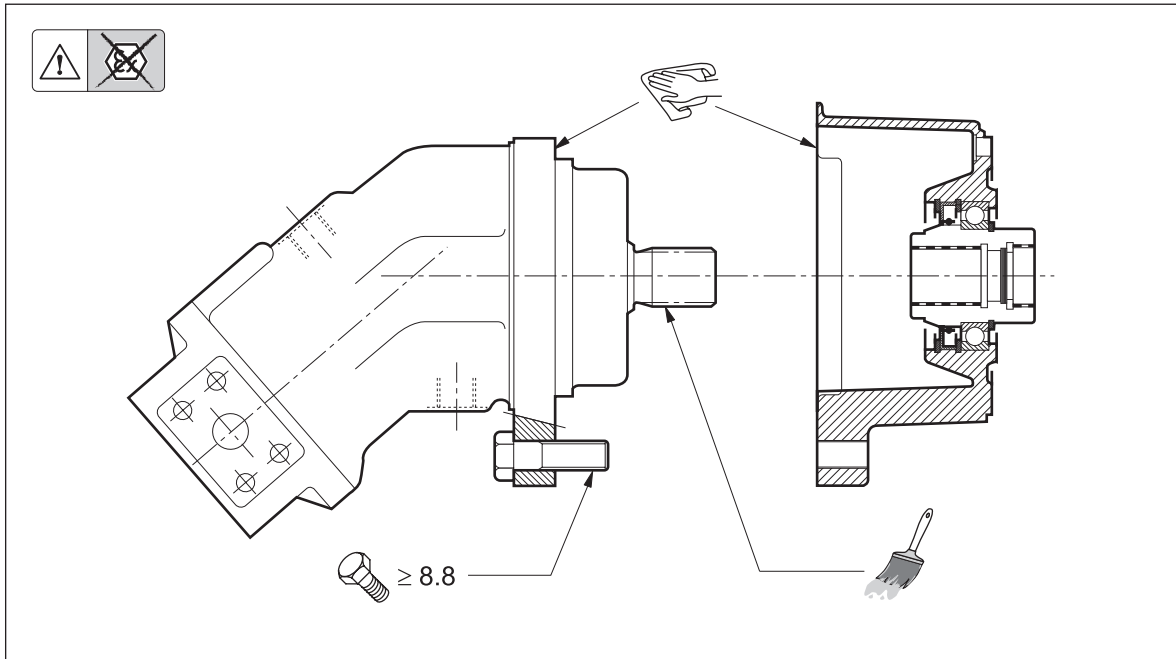

5.4 CONNECTING THE HYDRAULIC BRAKE

On gear units designed for coupling to hydraulic motors and fitted with a brake, connect the brake control fitting to the hydraulic circuit at the time of assembly.

Start-up

The minimum pressure to release the brake (see chart) must be less than 320 bar.

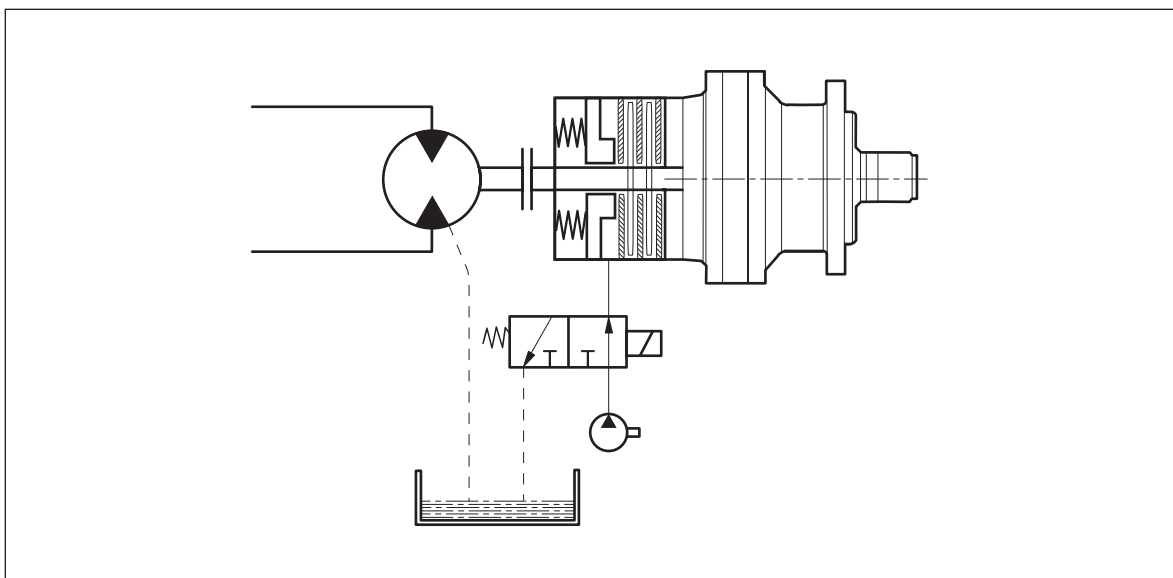



Technical data

Brake		4...						5...				6...							
		A	B	D	F	H	K	L	B	C	E	G	K	B	C	E	G	K	L
Braking torque	$M_{bs} \left[\begin{matrix} \text{Nm} \\ \pm 10\% \end{matrix} \right]$	50	100	160	260	330	400	440	400	500	630	800	1000	850	1100	1500	2100	2600	3200
Minimum release pressure	bar	10	20	30	20	25	30	33	20	27	20	25	32	14	19	25	19	24	28
Max. pressure	bar	320																	
Weight	kg	10						18				35							

NOTE: The static torque M_{bs} is the maximum torque the brake can exert. Under dynamic loads the braking torque is reduced. The actual M_{bs} values can vary from -5% to +15% of the rating given in the chart.

Installing the gearmotor

If a gearmotor is supplied fully assembled, follow the precautions and instructions given above when mounting to the machine.

For the electrical and hydraulic connection, refer instead to the two sample diagrams below.

These are generic only since each specific installation has its own special requirements, which must be evaluated on a per case basis by the Manufacturer.

Drive with electric motor.

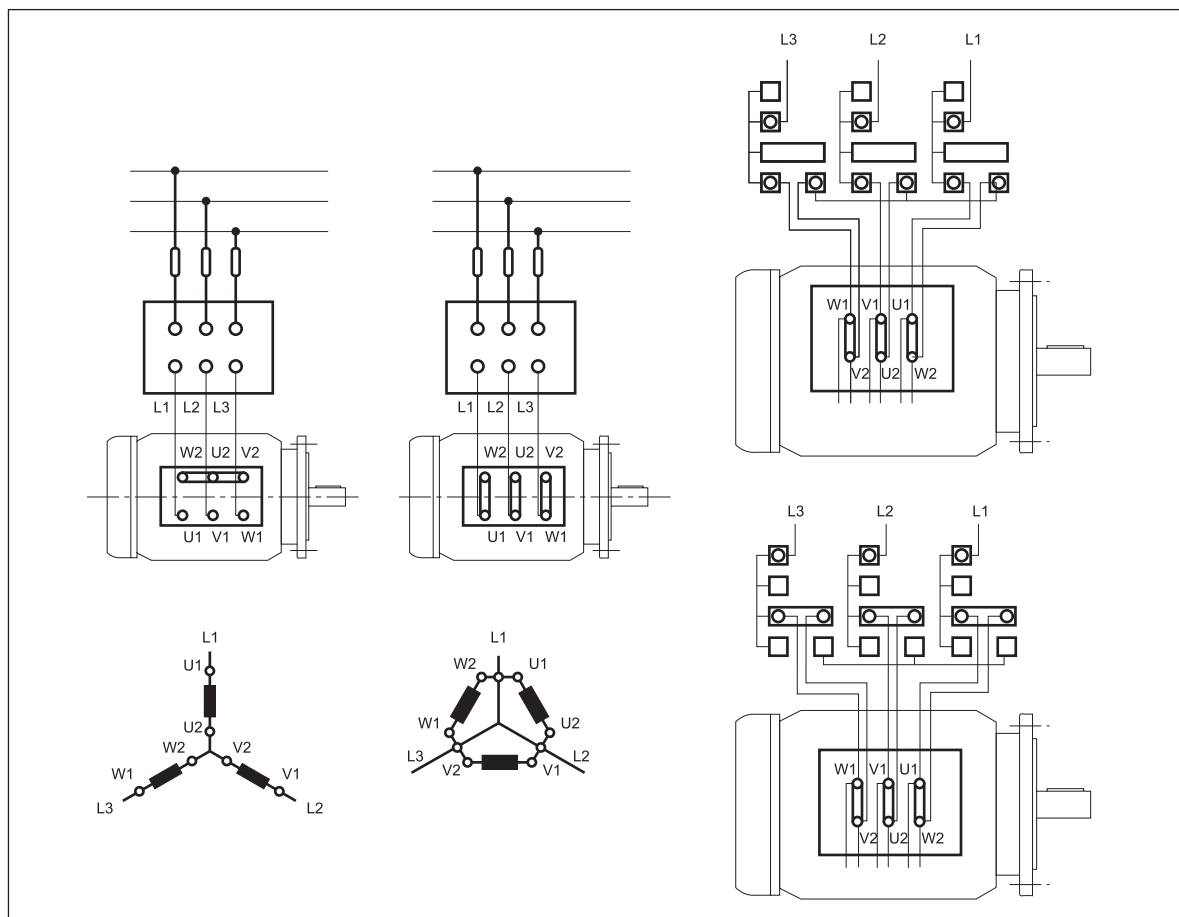

Drive with TRASMITAL MG orbital hydraulic motor

In addition to the instructions governing installation of the gear unit, the following instructions should also be observed when installing a hydraulic motor.

a) Connecting to the hydraulic circuit

The motor can be installed on both a closed and open loop circuit.

In the case of an open circuit installation, the solenoid valve or control valve may be of either the closed centre or open type.

The circuit line corresponding to the hydraulic motor delivery port must always be equipped with a pressure relief valve calibrated to a pressure no greater than the motor's p_{max} . Refer to the hydraulic circuit diagrams below.

Closed loop circuit

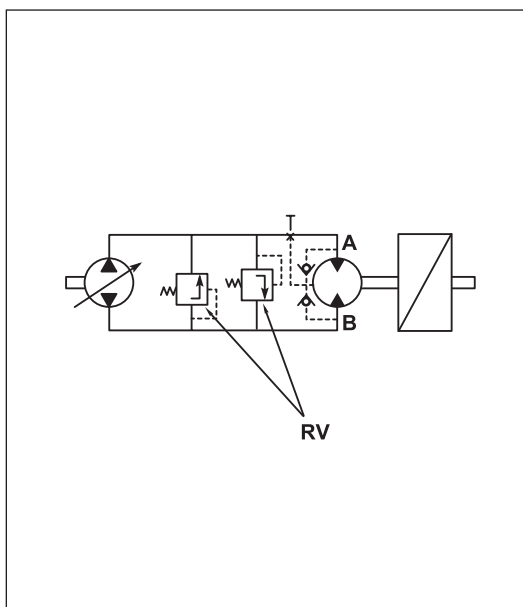

Open loop circuit

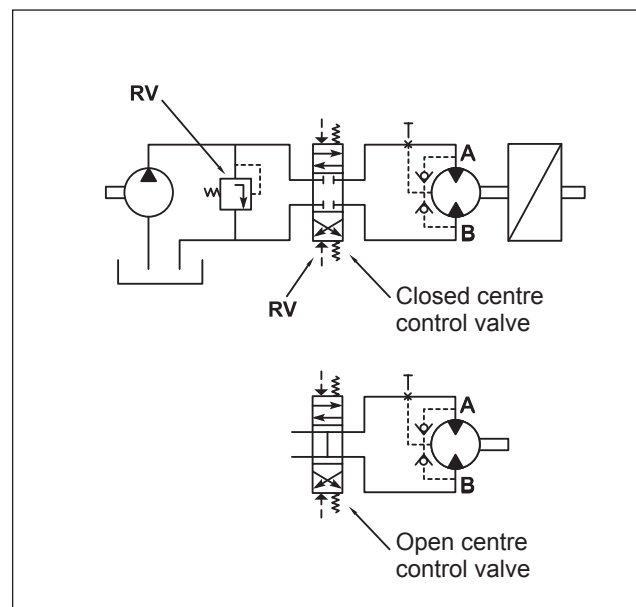

RV = pressure relief valves calibrated to $p_{RV} < p_{max}$.

If this is not possible because the circuit must also actuate other equipment at a higher pressure, or the control valve is of the closed centre type and the motor drives components with high inertia, auxiliary pressure relief valves must be installed as close as possible to the motor.

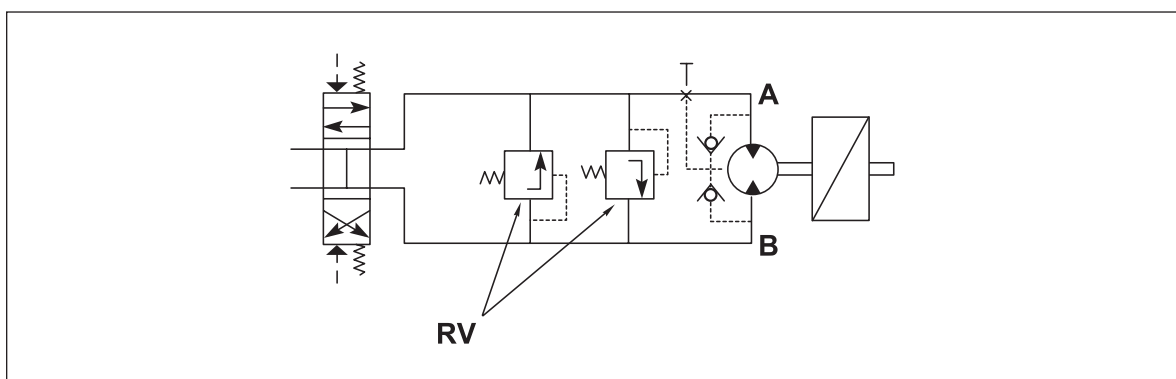

RV = pressure relief valves calibrated to $p_{RV} < p_{max}$.



b) Connecting drain port T

These motors have a 1/8" G drain hole in the centre of the cover. The motor is supplied with the port closed by a metal plug (see figure below).

Two non-return valves are incorporated in the motor casing to maintain internal pressure at the same level as the low pressure line A or B if the drain port is not connected to the tank.

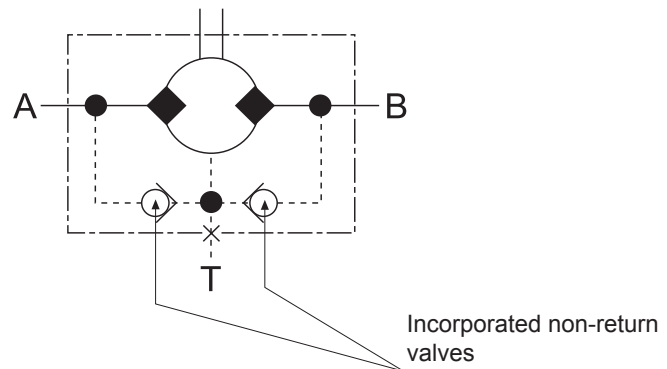

- 1) If the drain port is connected up, pressure at the shaft seal is always equal to the pressure in the drain line.
- 2) If the drain port is closed off, pressure at the shaft seal never exceeds pressure in the return line.

The maximum values for pressure in the drain line (case 1) or return line (case 2) are given in the following figure (for continuous and intermittent operating conditions).

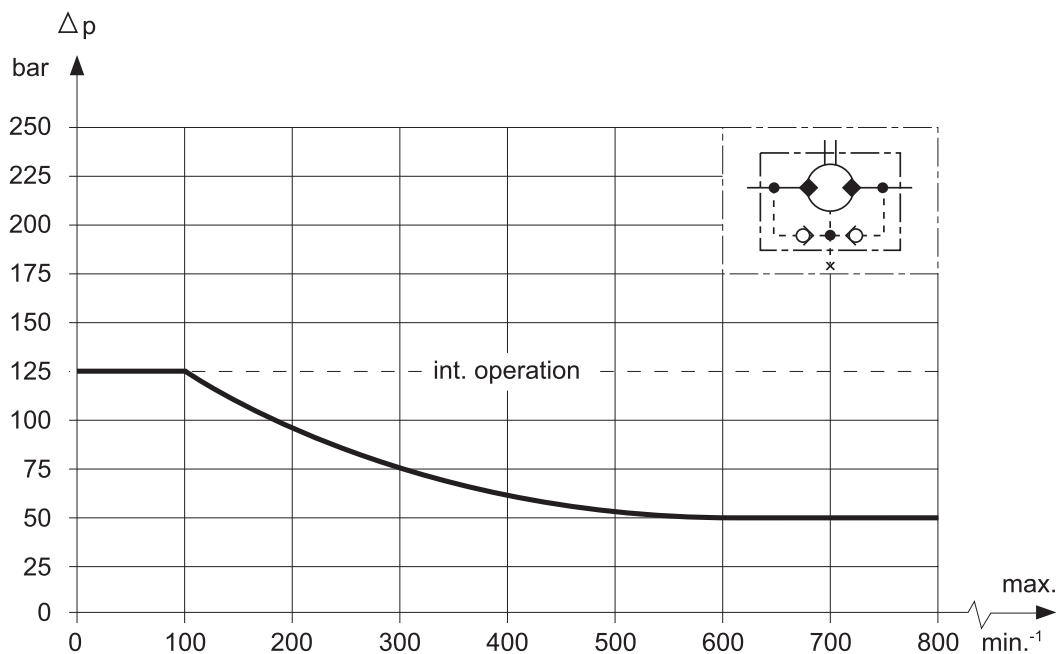

The drain port must always be connected up when more motors are operated in series.

c) Brake control

For gearmotors equipped with brakes, there are two motor versions available, i.e. the B02P or P010 executions.

In the B02P version, the motor has an in-built, direct brake control system.

In the P010 version, an auxiliary branching is required to control the brake.

See the following diagram.

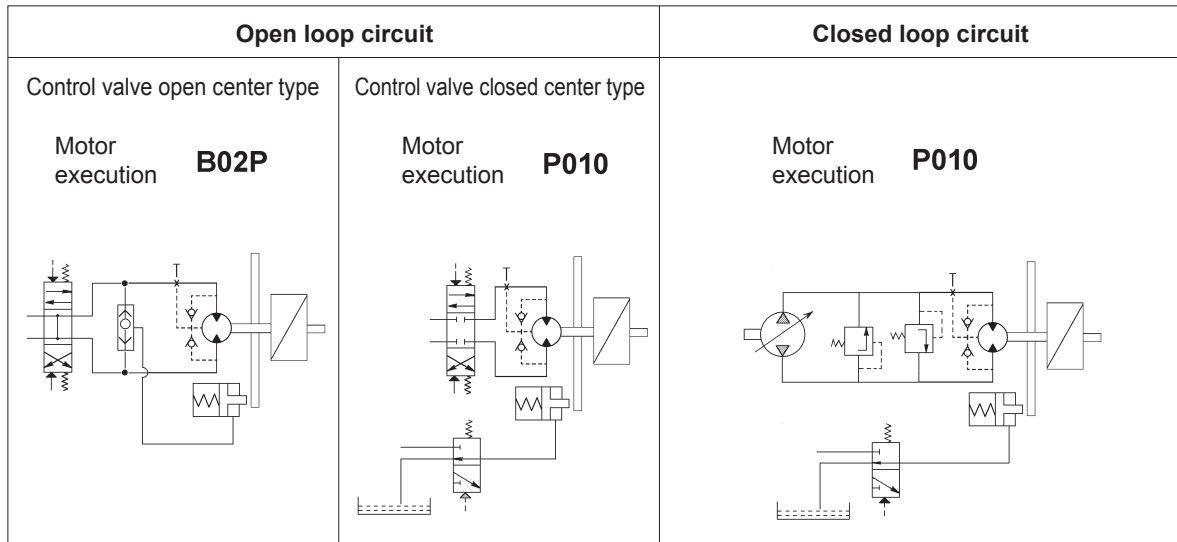

d) Hydraulic oil

Use hydraulic mineral oil with viscosity ISO VG 46 (46 Cst at $t = 40^{\circ}\text{C}$).

e) Oil filtering

For reliable motor operation and long life, it is important that the hydraulic circuit has a filter for a proper oil filtering according to the following degree:

degree 9 NAS 1638

degree 6 SAE

degree 18/15 SO DIS 4406



Drive with hydraulic motor

All motors must be charged with hydraulic fluid before being operated and during installation. Position the drain hole so that it is positioned uppermost for charging with fluid.

Make sure the hoses are routed in such a way as to prevent the motor casing from emptying and hence, prevent air pockets from forming which may affect pump suction during operation.

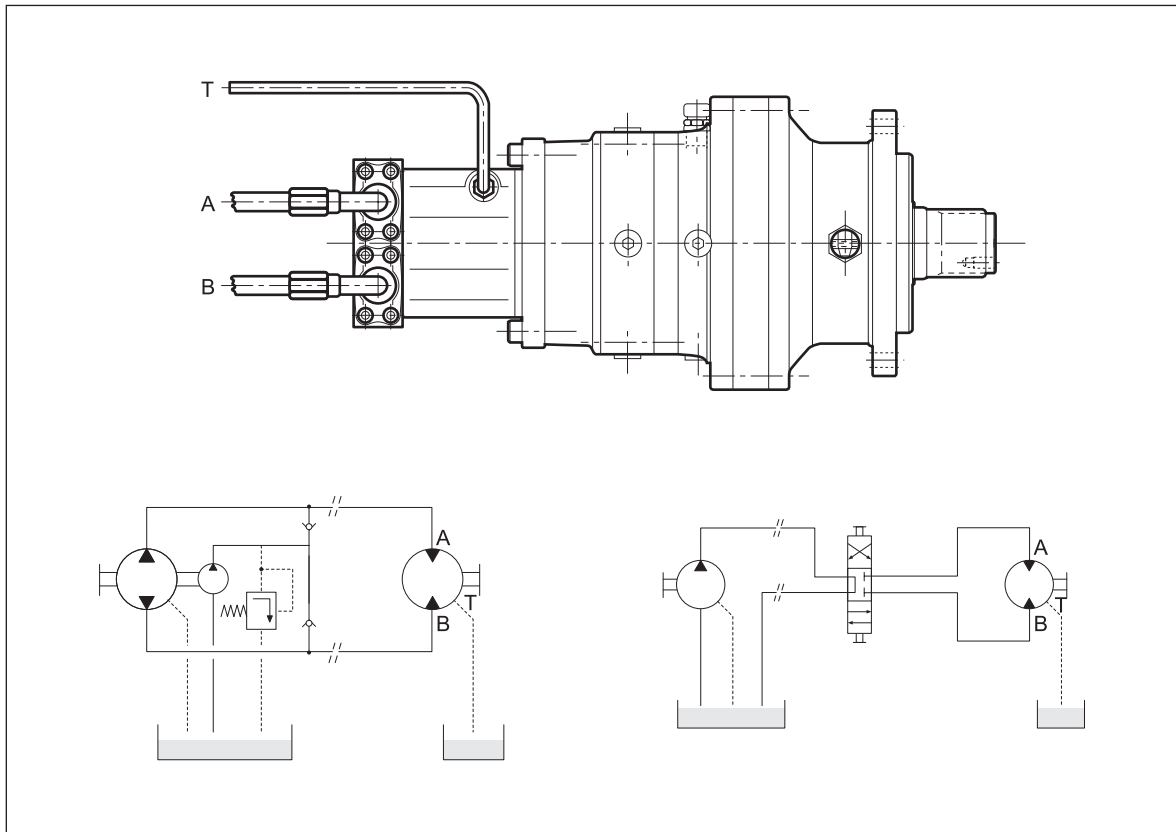

A - B = Supply lines

T = Drainage

5.5 LUBRICATION

Before starting up the gear unit, it must be charged with lubricant to the level corresponding to its specified mounting position.



The lubricant and its relative viscosity should be selected from the following chart, in accordance with the type of duty and ambient temperature. If the gear unit is supplied ready charged with lubricant, replace the closed shipping plug with the vent plug included in the shipment before installing it.

(A 1)

Plug thread	Pitch	Tightening torque [Nm]
M14	1.5	15 - 20
M16	1.5	15 - 20
M18	1.5	15 - 20
M20	1.5	20 - 30
M22	1.5	20 - 30
M24	1.5	20 - 30
M30	2	30 - 40
M42	3	40 - 50

Plug thread	Pitch	Tightening torque [Nm]
1/8"	28	10 - 15
1/4"	19	10 - 15
3/8"	19	15 - 20
1/2"	14	20 - 30
3/4"	14	20 - 30
1"	11	30 - 40

Industrial plants

(A 2)

											Mobil							
	Omala S4 WE	Omala S4 GXV	Omala S2 GX	Blasia	Blasia SX	Blasia S	Klübersynth GH 6	Klübersynth UH1 6	Klübersynth GEM2	Klüberoil GEM1	Mobil Glygoyle	Mobil SHC GEAR	Mobil SHC 600	Mobilgear XMP	Mobil Glygoyle (USDA H1)	Alphasyn PG 320	Carter SG	Nevastane SY
300 300M			*	*	*			F	*	*		*	*	*	F			F

F Food grade.

■ Recommended use.

***** Permitted use. The manufacturer cannot guarantee the quality or suitability of lubricants. Characteristics must be verified directly with the manufacturer of the chosen lubricant (or ask Bonfiglioli Technical Service for oil certification).

■ PolyAlkylene Glycol (PAG) synthetic oil (API group V)

□ PolyAlphaOlefin (PAO) synthetic oil (API group IV)

■ Mineral oil with EP additives



Mobile machines

(A 3)

	SAE standard .. API GL5 grade	
T _a	-20°C / +30°C	+10°C / +45°C
	SAE 80W/90	SAE 85W/140
Shell	Spirax HD	Spirax HD
Mobil	Mobilube HD	Mobilube HD
AGIP	Rotra MP	Rotra MP
Aral	Getriebeol HYP	Getriebeol HYP
BP	Hypogear EP	Hypogear EP
Castrol	Hypoy	Hypoy
Cepsa	Transmisiones EP	Transmisiones EP
Chevron	RPM Universal Gear Lubricants	RPM Universal Gear Lubricants
Fuchs	Titan Super Gear	Titan Super Gear
Total	Transmission TM	Transmission RS

Brake lubrication

The hydraulic multi-disk brakes are lubricated with the same oil as the gear unit.

 	<p>Only synthetic lubricants may be used on gear units conforming to European Directive 2014/34/EU. Refer to the above chart for the brand and type.</p>
------	---





5.5.1 LONG TERM STOCK (optional variant)

In presence of the Long Term Stock option the configured product is supplied without the standard lubricant oil but with an anticorrosive protective liquid to grant the integrity and full functionality of the gear unit in those cases where the unit will not be installed immediately but it has to be stocked for a long period of time (installation later than 6 months from delivery).

The Long Term Stock anticorrosive protective liquid can be requested in 2 versions according to the option requested by the customer in the product configuration phase:

1) **SLM: LONG TERM STOCK_MINERAL OIL**

With this option the anticorrosive protective liquid is compatible with all mineral-based oil lubricants listed in the following table:







LUBRICANT USED FOR THE GEARBOX OPERATION	
BRAND	PRODUCT NAME
 Shell	Omala S4 WE
	Omala S2 GX
 Agip	Blasia
	Blasia SX
 KLÜBER LUBRICATION	Klübersynth GEM2
	Klüberoil GEM1
 Mobil	Mobil SHC Gear
	Mobil SHC 600
	Mobilgear XMP



Do not use in gear units that will be filled with oil lubricants suitable for contact with food.

2) **SLP: LONG TERM STOCK_POLYGLYCOL OIL**

With this option the anticorrosive protective liquid is compatible with all polyglycol-based oil lubricants listed in the following table:

LUBRICANT USED FOR THE GEARBOX OPERATION	
BRAND	PRODUCT NAME
 Shell	Omala S4 WE
 Agip	Blasia S
 KLÜBER LUBRICATION	Klübersynth GH 6
 Mobil	Mobil Glygoyle
 Castrol	Alphasyn PG 320
 TOTAL	Carter SG



Do not use in gear units that will be filled with oil lubricants suitable for contact with food.

Preparatory activities for the commissioning of a product with Long Term Stock option

The activities that must be carried out for the commissioning of the gear unit or gearmotor with Long Term Stock option by the expiry of the service contract are:

- the customer must remove the unit from the packaging and the VCI protective bag
- before being put into service, the gear unit or gearmotor with Long Term Stock option requires some precautions:

· case A | anticorrosive protective liquid compatible with oil lubricant

before put the gear unit or gearmotor with Long Term Stock option into service, the product must be filled with a compatible oil lubricant.

When the product with Long Term Stock option is selected, Bonfiglioli supplies a separate breather plug that must be inserted on the unit before put it into service.

The filling and draining plugs are closed caps and comes already mounted on the gear units.

During the installation, the filling plug must be removed. Subsequently, the oil lubricant has to be filled of the corresponding quantity to the mounting position shown on the product's nameplate.

After the oil lubricant filling and before put the product into service, the breather plug supplied with the product must be inserted on the unit in place of the filling plug which had previously been removed.

· case B | anticorrosive protective liquid not compatible with oil lubricant

before put the gear unit or gear motor with Long Term Stock into service, the product must receive the following precautions:

- 1) empty the anticorrosive protective liquid;
- 2) fill the unit with a small amount of type compatible oil lubricant used to remove the residual of anticorrosive protective liquid. The small amount of oil lubricant has to equal to 20% of the oil lubricant expected for the horizontal mounting position;
- 3) perform a rotation test ("washing test" without load) to distribute the oil lubricant internally and at the end of this activity drain the small amount of oil lubricant in order to remove the residual of anticorrosive protective liquid;
- 4) fill the unit again with a type compatible oil lubricant based on the corresponding quantity to the mounting position shown on the product's nameplate.

The filling and draining plugs are closed caps and comes already mounted on the gear units.

During the installation, the filling plug must be removed. Subsequently, the oil lubricant has to be filled of the corresponding quantity to the mounting position shown on the product's nameplate.

After the oil lubricant filling and before put the product into service, the breather plug supplied with the product must be inserted on the unit in place of the filling plug which had previously been removed.

6.0 TESTING THE GEAR UNIT

The gear unit has been factory tested by the Manufacturer. Before start-up, make sure that:

- this partly completed machinery must not be put into service until the final machinery into which it is to be incorporated has been declared in conformity with the provisions of the “Machinery Directive” 2006/42/EC
- the gear unit’s mounting position in the installation corresponds to that prescribed and indicated on the nameplate
- the electrical power supply is suitable and operational as prescribed in EN 60204-1, and is grounded as per EN 50014
- the motor’s electric power supply corresponds to that prescribed and is within +/-5% of the rated value
- the hydraulic system is suitable and operational, and the oil in the hydraulic motor’s lubrication circuit conforms to ISO VG 46. It must be filtered with a maximum grade of 10 µm and contamination level less than or equal to class 9 as per NAS 1638 or 18/15 as per ISO/DIS 4406
- there are no signs of lubricant leaks from the plugs or gaskets
- the vent plug is not obstructed by dirt or paint
- the unit does not run noisily or with excessive vibration.

Before starting up the unit, check and make sure that:

- the unit is not assembled in a potentially explosive atmosphere (oil, acid, gas, vapour, radiation) and is free of dust build ups greater than 5 mm in depth
- during operation the gear unit is sufficiently ventilated and is not subject to radiation from external heat sources
- the temperature of the cooling air does not exceed the values indicated in the chapter “ALLOWED TEMPERATURE LIMITS”.
- the oil level check and filler plugs and the vent plugs are all easily accessible
- all accessories mounted to the gear unit are ATEX certified
- gear units with hollow shafts, with or without shrink disk, have been correctly mounted as described in this manual
- the gear unit has been thoroughly cleaned after installation
- all guards are installed to prevent accidental contact between operators and the unit’s rotary moving parts, and seals are oil tight



7.0 USING THE EQUIPMENT

Before putting the gear unit into service, the User must ensure that the plant in which it is installed complies with all applicable directives, especially those regarding health and safety at work.



- The gear unit may not be used in areas and environments:
- with highly corrosive/abrasive vapours, smoke or dust.
 - in direct contact with loose food products.



Danger zones and exposed persons:

The danger zone of the gear unit is the protrusion of the shaft which constitutes a hazard for exposed persons in direct contact with it (crushing, shearing, trapping). In particular, when the gear unit is operating in automatic mode in an accessible area, the shaft must be protected by a guard.



8.0 MAINTENANCE



Maintenance and replacement work must be carried out by expert maintenance technicians trained in the observance of applicable laws on health and safety at work and the special ambient problems attendant on the installation.



Before doing any work on the unit, the operator must first switch off power to the gear unit and ensure that it is out of service, as well as taking all necessary precautions against it being accidentally switched on again or its parts moving without warning (due to suspended loads or similar external factors).

Furthermore, all additional environmental safety precautions must be taken (e.g. elimination of residual gas or dust, etc).

- Before doing any maintenance work, activate all the safety devices provided and, if necessary, inform persons working in the vicinity. Cordon off the area around the unit and prevent access to any equipment which, if activated, might be the cause of unexpected health and safety hazard.
- Replace worn components with original spare parts.
- Use the lubricants (oil and grease) recommended by the Manufacturer.
- When working on the gear unit always replace all gaskets and seals with original new ones.
- If a bearing requires replacement, it is good practice to also replace the other bearing supporting the same shaft.
- We recommend replacing the lubricating oil after all maintenance work.

The above instructions are aimed at ensuring efficient and safe operation of the gear unit.

The Manufacturer declines all liability for injury to persons and damage to components due to the use of non-original spare parts and non-routine work that modifies the safety requirements without the Manufacturer's express prior authorisation.

Refer to the specific spare parts catalogue when ordering spare parts for the gear unit.



Do not dump polluting liquids, worn parts and maintenance waste into the environment. Dispose of all such materials as specified by applicable legislation.



- Observe the routine inspection and maintenance schedule to ensure the unit's correct operation and the effectiveness of the explosion protection.
- Always apply fresh Loctite 510 or other product with similar properties and application range to all disassembled threads.
- Before servicing or repairing internal components, allow the gear unit to cool down completely before opening the casing so as to avoid burns from parts which are still hot.
- On completion of maintenance work, make sure that all safety measures and equipment have been applied and reset.
- Clean the gear unit thoroughly after maintenance and repair work.
- On completion of maintenance, tighten all vent, filler and level plugs to their specified torques (chart A1).
- On completion of any maintenance work all seals must be refitted and sealed as prescribed.
- Regardless of the type of gear unit, whenever a seal ring is replaced its lips should be smeared with a thin layer of grease (Fluorocarbon gel 880 ITP or other product with similar properties and application range) before assembly.
- Use only original spare parts for repairs.

8.1 ROUTINE MAINTENANCE



Keep the gear unit at its maximum efficiency by following the routine maintenance schedule. Good maintenance ensures the unit's maximum performance, extended service life and continued compliance with safety regulations.

(A 4)	Inspection parameter	Frequency
	Oil changes	see specific table
	Oil pressure (if there are a circuits)	24 h
	Noise, vibration	24 h
	External condition of gearbox (fouling, oil deposits)	170 h ... 720 h
	Oil leaks, external seals and gaskets	720 h
	Oil level	720 h
	Oil filter contamination indicator (where required)	720 h
	Regrease bearing (where required)	see specific table
	Vent filter (where required)	2200 h
	Tightness of fixing bolts, connecting flanges and torque transmission components	2000 h ... 4000 h
	Check the elastic elements in all joints for wear (where required)	2000 h ... 4000 h
	Regrease the Drywell device (on series where provided) and seals (where required)	2000 h ... 4000 h
	Check cup springs for wear and adjust the torque arm	3000 h
	Condition of torque arm polymer bushes (aging, cracking)	3000 h
	Alignment of gearbox shafts with respect to coupled machine shafts at each oil change	9000 h ... 18000 h
	Cleanliness of electric motor fan and fan cowling (if present) and cleanliness of gearbox body	at each oil change

Depending on the temperature reached by the lubricant, it should be replaced at the intervals indicated in the table below.

Average oil operating temperature [C°]	Interval replacement [h]		
	mineral oil	synthetic oil	
	EP(*)	PAO	PAG
$t_o < 65$	8000	25000	25000
$65 < t_o < 80$	4000	15000	15000
$80 < t_o < 95$	2000 (@) (#)	12500	12500

(*) = Replacement within 1 year

(@) = It is not advised continuous operation in this range of oil temperature: 80°C to 95 °C

(#) = Recommended checking every 6 months



For installations in zones 21 and 22 the User must schedule and implement a regular cleaning programme for all surfaces and recesses to avoid dust build-ups of more than 5 mm in depth.



Every 1000 hrs. of operation or after 6 months:

• Measure the surface temperature at the coupling between the gear unit and motor, and at the points which are most shielded from the motor's cooling fan. The maximum temperature must not exceed the values given in the chapter "ALLOWED TEMPERATURE LIMITS", nor may this value be exceeded during operation.



Every 5000 hrs. of operation:

• Change the synthetic oil and bearing grease if the gear unit is not life lubricated.
• Replace all externally accessible seal rings unless this has already been done as a result of problems occurring before the scheduled maintenance deadline.

8.2 OIL CHANGES

1. Place an adequate container under the drain plug.
2. Remove the filler and drain plugs and allow the oil to drain out.



The oil will drain better if it is warm.

3. Wait for a few minutes until all the oil has drained out, then screw the drain plug back on after first changing the plug seal.
4. Fill with new oil until it reaches the level mark. **Do not mix oils of different makes or specifications and check that the oil is highly resistant to foaming and is EP rated.**
5. Tighten down the filler plug after changing its seal.



The gear unit may be supplied with or without lubricant, as requested by the User. The quantity of charge oil required is specified in the Sales Catalogue. This specification is however, approximate, and reference must always be made to the mark on the level plug, the placement of which depends on the mounting position specified in the purchase order.

Life lubricated gear units which are not subject to external contamination do not normally require periodic lubricant changes. If the same type of oil as that already in use is not available, drain the gear unit casing completely and wash its interior thoroughly with a light solvent before refilling with the new lubricant.



If a leak is found, identify the cause of the fault and repair it before topping up the lubricant and operating the unit.



Lubricants, solvents and detergents are toxic/harmful to health:
- they may cause irritation in direct contact with the skin
- they may cause intoxication if inhaled
- they may be fatal if swallowed.



Handle them with care using suitable individual safety equipment. Do not dump them into the environment and dispose of in accordance with applicable legislation.

8.3 CHECKING OPERATIONAL EFFICIENCY

- Remove any dust from the gear unit and motor casings.
- Check that the noise generated at continuous load does not vary. Excessive vibration or noise can indicate wear of the gear train or failure of a bearing.
- Check the power absorption and voltage against the rated values given on the motor's name-plate.
- Check the wear of the friction surfaces and braking gasket on the brake motors (if fitted) and, if necessary, adjust the gap.
- Check for lubricant leaks from the gaskets/seals, plugs and casings.
- Check all bolted couplings for wear, deformation and corrosion and tighten them down fully, but without over tightening.

8.4 CLEANING

Remove all dust and process waste from the gear unit. Do not use solvents or other products that are incompatible with the unit's construction material and do not direct high pressure jets of water at the gear unit.



9.0 REPLACING PARTS

- Immediately replace parts and components if they are not able to guarantee safe and reliable operation.
- Never improvise repairs.
- The use of non-original spare parts not only renders the warranty null and void but can jeopardise the gear unit's operation.

9.1 REMOVING THE MOTOR



If during operation the mobile coupling between the motor and gear unit has not rusted significantly, it should be possible to remove the motor without applying excessive force. If instead, it proves difficult to remove the motor, do not use screwdrivers or levers to apply force as this may damage the flanges and mating surfaces, but proceed as illustrated below.

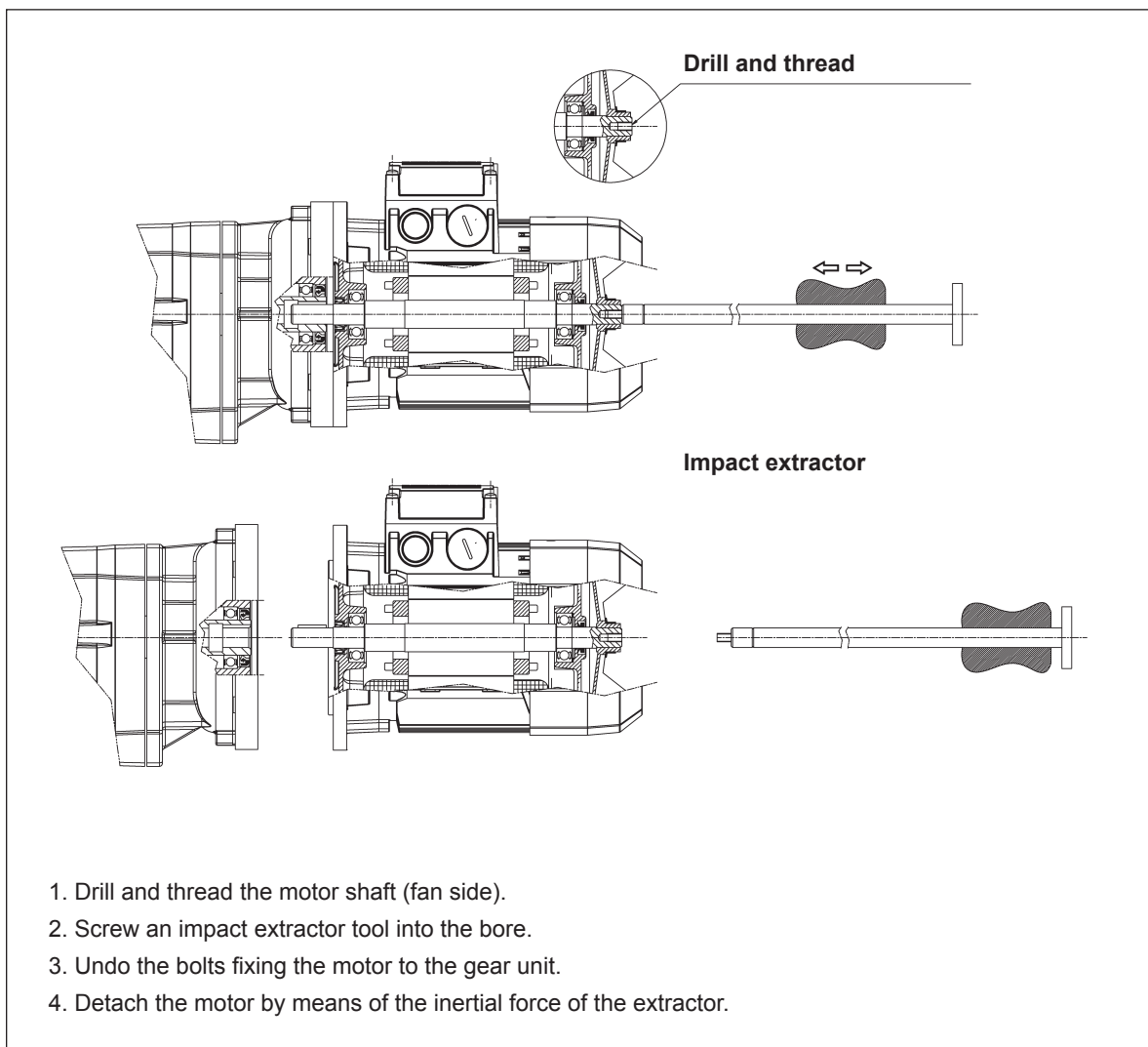

9.2 DECOMMISSIONING THE GEAR UNIT

The unit must only be taken out of service by operators trained in the observance of applicable laws on health and safety at work.

Do not dump non-biodegradable products, lubricants and non-ferrous materials (rubber, PVC, resins, etc.) into the environment. Dispose of all such materials as stipulated by established environmental legislation.



Do not re-use parts or components which appear to be in good condition after they have been checked or replaced by qualified personnel and declared unsuitable for use.

10.0 TROUBLESHOOTING

The following information is intended to serve as an aid in locating and eliminating defects and faults. In some cases, problems may be caused by the plant or machine to which the gear unit is assembled and hence, the cause and remedy will be described in the Manufacturer's technical documentation for the machine/plant in question.

FAULT	CAUSE	REMEDY
Bearing temperature too high	Oil level too low	Top up oil level
	Oil spent	Replace oil
	Defective bearings	Contact authorised workshop
Operating temperature too high	Oil level too high	Check oil level
	Oil spent	Replace oil
	Contaminant in oil	Replace oil
Abnormal running noise	Gears damaged	Contact authorised workshop
	Bearing axial backlash too high	Contact authorised workshop
	Bearings defective or worn	Contact authorised workshop
	Excessive load applied	Correct load to rated values given in Sales Catalogue
	Contaminant in oil	Replace oil
Abnormal noise at gear unit mounting	Mounting bolts loose	Tighten bolts to specified torque
	Mounting bolts worn	Replace bolts
Oil leaks	Oil level too high	Check oil level
	Casing/coupling seals inadequate	Contact authorised workshop
	Gaskets worn	Contact authorised workshop
Gear unit does not run or runs with difficulty	Oil viscosity too high	Replace oil (see recommended lubricant chart)
	Oil level too high	Check oil level
	Excessive load applied	Redesign drive for actual load required
Output shaft does not turn with motor running	Gears damaged	Contact authorised workshop



ANNEX 1 - CHECKING THE OIL LEVEL ON ATEX-SPECIFIED GEAR UNITS

Gear units are normally fitted with oil level check plugs.
To check the oil level, first identify the level plug.

- Horizontal position:

Remove the plug and insert a bar of the right size in the hole and of the shape shown in the figure.

- Vertical position:

Use a rod to check that the oil level is between the MIN and MAX marks, then screw the plug back in.

If the level is more than 3 mm below the spill level, top up and check the reason for the drop in oil level.

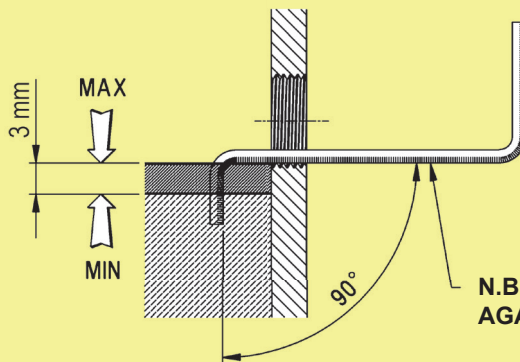



N.B.: MAKE SURE THE ROD IS POSITIONED FLAT AGAINST THE EDGE OF THE THREADED HOLE

Gear units conforming to Directive 2014/34/EU and designed for a vertical mounting position, are normally equipped with an oil expansion chamber fitted with service plugs for filling, checking the oil level and venting internal overpressure.

ANNEX 2 - LUBRICANT CHARGE QUANTITY

3_L Series

		Mounting position		
		A	T	O
300	L1	0.6	1.0	0.9
	L2	0.9	1.3	1.2
	L3	1.2	1.6	1.5
	L4	1.5	1.9	1.8
301	L1	0.8	1.2	1.1
	L2	1.1	1.5	1.4
	L3	1.4	1.8	1.7
	L4	1.7	2.1	2.0
303	L1	1.3	2.3	2.0
	L2	1.6	2.6	2.3
	L3	1.9	2.9	2.6
	L4	2.2	3.2	2.9
304	L1	1.4	2.4	2.2
	L2	1.9	2.9	2.7
	L3	2.2	3.2	3.0
	L4	2.5	3.5	3.3
305	L1	1.6	2.6	2.4
	L2	2.1	3.1	2.9
	L3	2.4	3.4	3.2
	L4	2.7	3.7	3.5
306	L1	2.5	3.5	3.2
	L2	3.3	4.3	4.0
	L3	3.6	4.6	4.3
	L4	3.9	4.9	4.6
307	L1	3.5	5.0	4.5
	L2	4.5	6.0	5.5
	L3	5.0	6.5	6.0
	L4	5.3	6.8	6.3
309	L1	4.0	5.5	5.0
	L2	5.0	6.5	6.0
	L3	5.5	7.0	6.5
	L4	5.8	7.3	6.8

		Mounting position		
		A	T	O
310 310M	L1	5.0	6.5	6.0
	L2	6.3	7.8	7.3
	L3	7.1	8.6	8.1
	L4	7.4	8.9	8.4
311 311M	L1	7.0	12	10
	L2	9.0	14	12
	L3	10	15	13
	L4	11	16	14
313 313M	L1	9.0	14	12
	L2	12	17	15
	L3	13	18	16
	L4	13	18	16
314 314M	L2	17	25	21
	L3	19	27	23
	L4	20	28	24
315 315M	L2	19	27	23
	L3	21	29	25
	L4	22	30	26
316 316M	L2	22	30	26
	L3	24	32	28
	L4	25	33	29
317 317M	L2	26	41	36
	L3	29	44	39
	L4	30	45	40
318 318M	L3	40	55	50
	L4	43	58	53
319	L3	50	70	60
	L4	53	73	63
321	L3	56	76	66
	L4	60	80	70
323	L3	Contact Bonfiglioli Riduttori Technical Service		
	L4			
325	L3			
	L4			

N.B. Oil quantities are indicative. Check actual level after filling through the appropriate plug.





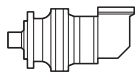











3_R Series

		Mounting position		
		B0	U_	P_
300	R2	1.2	1.7	1.5
	R3	1.5	2.0	1.8
	R4	1.8	2.3	2.1
301	R2	1.6	2.1	1.9
	R3	1.9	2.4	2.2
	R4	2.2	2.7	2.5
303	R2	2.2	2.8	2.6
	R3	2.5	3.1	2.9
	R4	2.8	3.4	3.2
304	R2	2.3	2.9	2.7
	R3	2.8	3.4	3.2
	R4	3.1	3.7	3.5
305	R2	2.5	3.1	2.9
	R3	3.0	3.6	3.4
	R4	3.3	3.9	3.7
306	R2	4.0	5.0	4.8
	R3	4.8	5.8	5.6
	R4	5.1	6.1	5.9
307	R2	6.0	8.0	7.0
	R3	7.0	9.0	8.0
	R4	7.5	9.5	8.5
309	R2	6.5	8.5	7.5
	R3	7.5	9.5	8.5
	R4	8.0	10	9.0

		Mounting position		
		B0	U_	P_
310 310M	R2	13	15	14
	R3	11	13	12
	R4	12	14	13
311 311M	R2	14	19	17
	R3	16	21	19
	R4	17	22	20
313 313M	R2	16	21	19
	R3	19	24	22
	R4	20	25	23
314 314M	R3	25	33	29
	R4	28	36	32
315 315M	R3	27	35	31
	R4	30	38	34
316 316M	R3	30	38	34
	R4	33	41	37
317 317M	R3	38	52	48
	R4	42	56	52
318 318M	R4	48	63	58
319	R4	55	70	65
321	R4	60	75	70

N.B. Oil quantities are indicative. Check actual level after filling through the appropriate plug.

3/V Series

	 																	
	AA - EA - FD			AF - EF - FE			AE - EE - FF			AD - ED - FA			TA - TE - TF TD - VA - VE VF - VD		OA - OE - OF OD - QA - QE QF - QD			
		input 	HS		input 	HS		input 	HS		input 	HS		input 	HS		input 	HS
3/V 00 L3	0.90			0.90			0.90			0.90			1.3			1.2		
3/V 01 L3	1.1	0.12	0.12	1.1	0.12	0.12	1.1	0.12	0.12	1.1	0.12	0.12	1.5	0.12	0.12	1.4	0.12	0.12
3/V 03 L3	1.6	0.25	0.25	1.6	0.31	0.31	1.6	0.31	0.31	1.6	0.38	0.38	2.6	0.31	0.31	2.3	0.25	0.25
3/V 04 L3	1.9	0.38	0.38	1.9	0.43	0.43	1.9	0.43	0.43	1.9	0.52	0.52	2.9	0.52	0.52	2.7	0.38	0.38
3/V 05 L3	2.1	0.38	0.38	2.1	0.43	0.43	2.1	0.43	0.43	2.1	0.52	0.52	3.1	0.52	0.52	2.9	0.38	0.38
3/V 06 L3	3.3			3.3			3.3			3.3			4.3			4.0		
3/V 10 L4 , 10M L4	7.1	0.64	0.64	7.1	0.76	0.76	7.1	0.76	0.76	7.1	0.85	0.85	8.6	0.76	0.76	8.1	0.76	0.76
3/V 07 L3	4.5			4.5			4.5			4.5			6.0			5.5		
3/V 11 L4 , 11M L4	10	2.4	2.8	10	2.6	2.6	10	2.6	2.6	10	1.7	1.7	15	1.9	1.9	13	1.9	1.9
3/V 13 L4 , 13M L4	13			13			13			13			18			16		
3/V 09 L3	5.0			5.0			5.0			5.0			6.5			6.0		
3/V 10 L3 , 10M L3	6.3			6.3			6.3			6.3			7.8			7.3		
3/V 14 L4 , 14M L4	19	4.3	4.5	19	3.9	3.9	19	3.9	3.9	19	3.0	3.0	27	3.5	3.5	23	3.5	3.5
3/V 15 L4 , 15M L4	21			21			21			21			29			25		
3/V 16 L4 , 16M L4	24			24			24			24			32			28		
3/V 11 L3 , 11M L3	9.0			9.0			9.0			9.0			14			12		
3/V 13 L3 , 13M L3	12			12			12			12			17			15		
3/V 14 L3 , 14M L3	17	7.8	9.6	17	6.7	6.7	17	6.7	6.7	17	5.0	5.0	25	5.5	5.5	21	5.5	5.5
3/V 17 L4 , 17M L4	29			29			29			29			44			39		
3/V 15 L3 , 15M L3	19			19			19			19			27			23		
3/V 18 L4 , 18M L4	40	11	15	40	8.9	8.9	40	9.4	9.4	40	7.5	7.5	55	9.5	9.5	50	9.5	9.5
3/V 19 L4	50			50			50			50			70			60		
3/V 16 L3 , 16M L3	22			22			22			22			30			26		
3/V 17 L3 , 17M L3	26	23	28	26	16.8	16.8	26	17.5	17.5	26	10.7	10.7	41	17	17	36	17	17
3/V 21 L4	56			56			56			56			76			66		

 Life lubrication

NOTE: In combined gear units, lubrication of the planetary stage is separate from that of the worm (3/V) or helical bevel (3/A) stages.



3/A Series

	[1]											
	AA - EA - FD		TA - TE - TF TD - VA - VE VF - VD		OA - OE - OF OD - QA - QE QF - QD		AD - ED - FA		AF - EF - FE		AE - EE - FF	
3/A 00 L2	0.60	1.4	1.0	1.4	0.90	1.4	0.60	1.4	0.60	1.4	0.60	1.4
3/A 01 L2	0.80	2.3	1.2	2.3	1.1	2.3	0.80	2.3	0.80	2.3	0.80	2.3
3/A 03 L2	1.3	3.2	2.3	3.2	2.0	3.2	1.3	3.2	1.3	3.2	1.3	3.2
3/A 04 L2	1.4	3.8	2.4	3.9	2.2	3.9	1.4	4.5	1.4	5.0	1.4	4.2
3/A 05 L2	1.6	4.0	2.6	4.1	2.4	4.1	1.6	4.7	1.6	5.2	1.6	4.4
3/A 06 L2	2.5	4.9	3.5	8.1	3.2	4.7	2.5	8.4	2.5	11	2.5	9.2
3/A 07 L2	3.5	6.8	5.0	8.1	4.5	12	3.5	15	3.5	18	3.5	15

Life lubrication

NOTE: In combined gear units, lubrication of the planetary stage is separate from that of the worm (3/V) or helical bevel (3/A) stages.

ANNEX 3 - MOUNTING POSITIONS AND PLUG POSITIONS

3_M_L - 3_L - 3_R Series

ALL GEARBOXES

- 1 Filling/breather oil plug
- 2 Oil level plug
- 3 Oil draining plug
- 4 Brake port

1 STAGE INLINE GEARBOXES

- 1A Filling/breather oil plug
- 3A Oil draining plug

2 STAGE RIGHT ANGLE GEARBOXES

- 1B Filling/breather oil plug
- 3B Oil draining plug

300 - 325 , 310M - 318M **A - E**

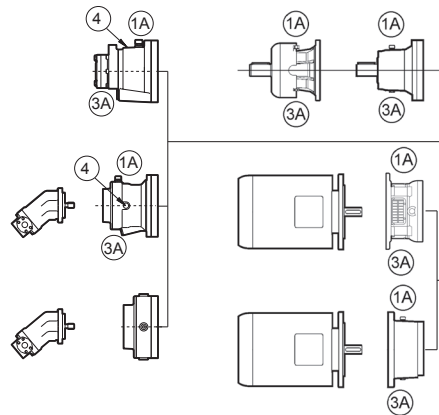

300 - 321 , 310M - 318M **B1 - B3 - I1 - I3**

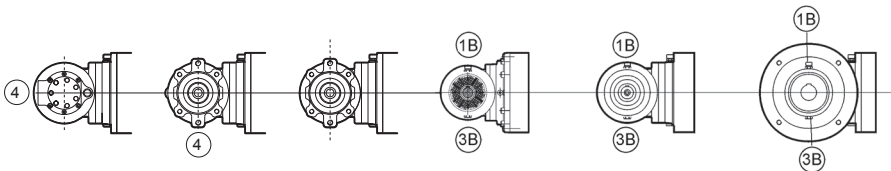

300 - 321 , 310M - 318M **B2 - I2**

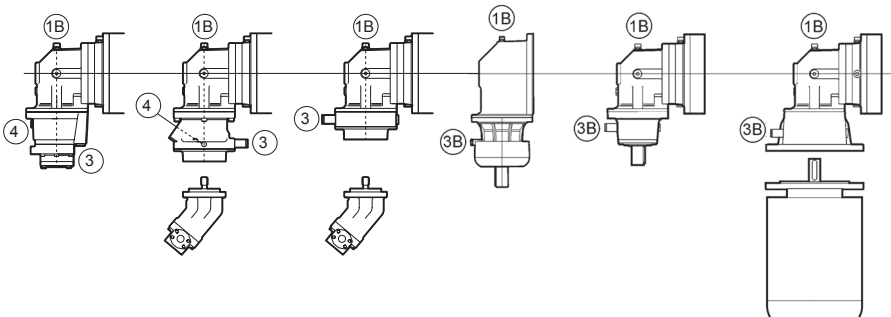

300 - 321 , 310M - 318M **B0 - I0**

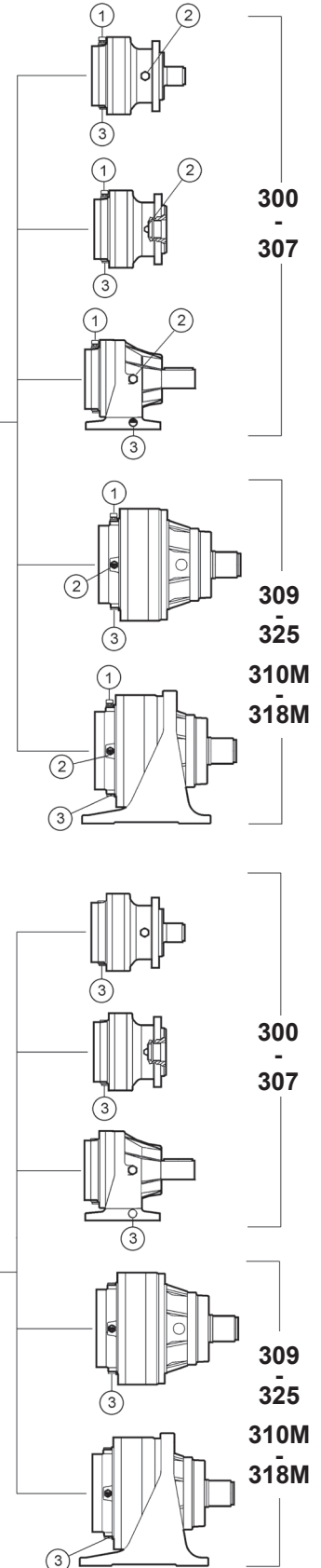
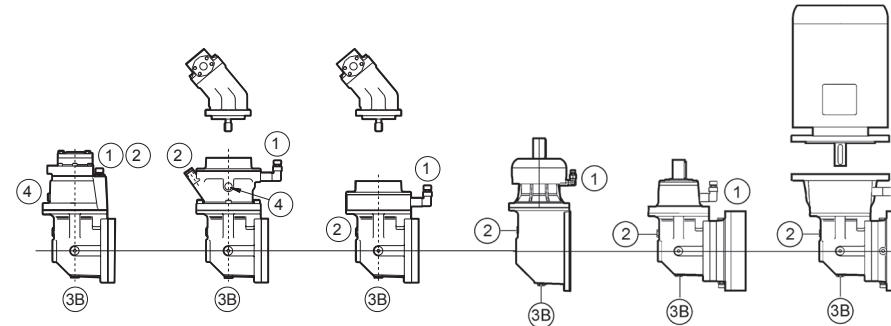



300 - 307

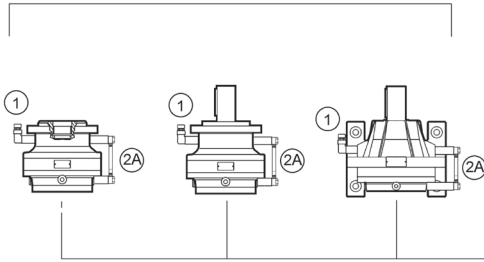

309 - 325, 310M - 318M

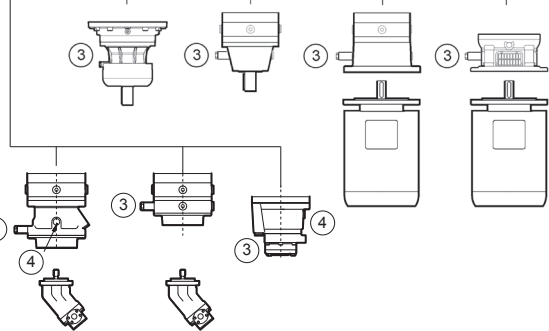
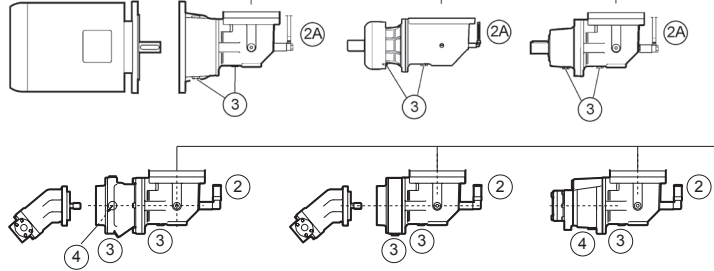
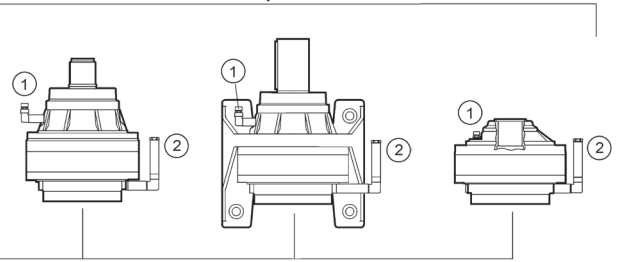

P0 - P1 - P2 - P3 R0 - R1 - R2 - R3 300 - 321, 310M - 318M

Q - O 300 - 325, 310M - 318M

ALL GEARBOXES

- 1 Filling/breather oil plug
- 2 Oil level plug

- 2A Transparent oil level hose
- 3 Oil draining plug

- 4 Brake port

- 5 Oil tank, for gearboxes in industrial application

U0 - U1 - U2 - U3 W0 - W1 - W2 - W3 300 - 321, 310M - 318M

T - V 300 - 325, 310M - 318M

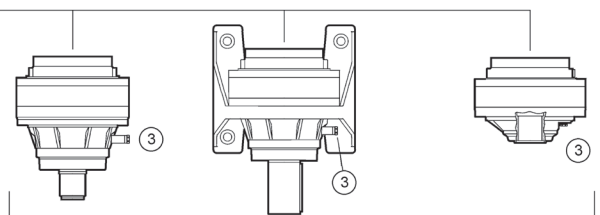
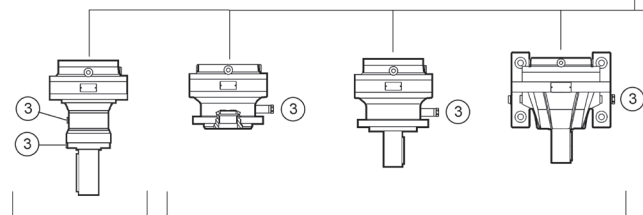
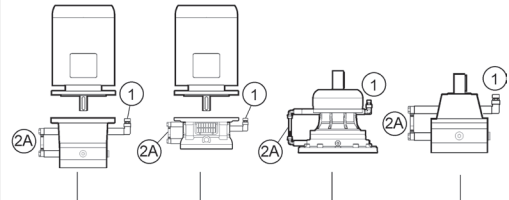
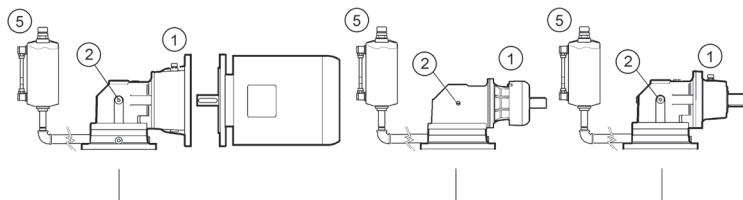
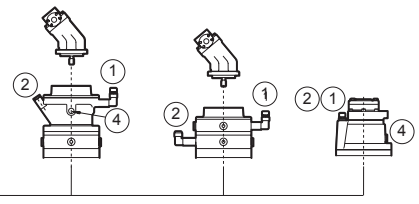
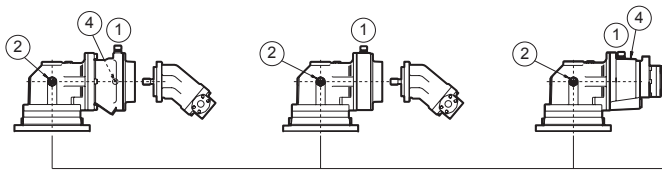

303 - 315 310M - 315M

300 - 307

309 - 325, 310M - 318M

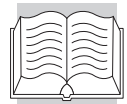

3/V M - 3/V Series

ALL GEARBOXES

(planetary stages)

- 1 Filling/breather oil plug
- 2 Oil level plug
- 3 Oil draining plug

(worm reduction module)

- 1V Filling/breather oil plug
- 2V Oil level plug
- 3V Oil draining plug

300 - 321 , 310M - 318M

A - E

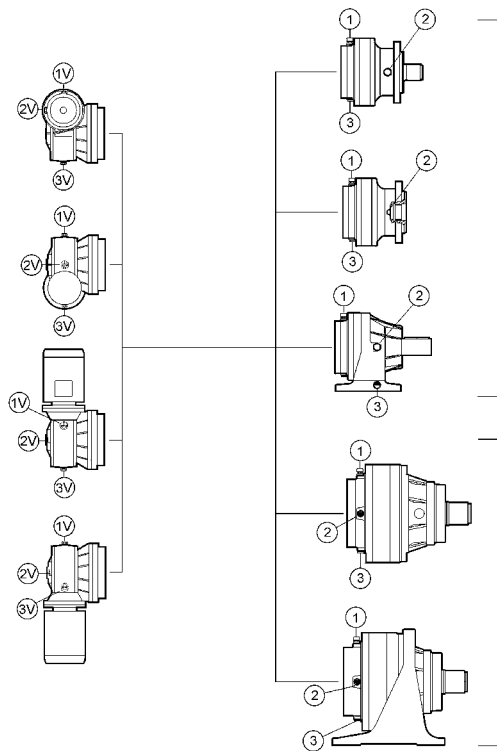

300 - 321 , 310M - 318M

O - Q

300 - 307

309 - 321 , 310M - 318M

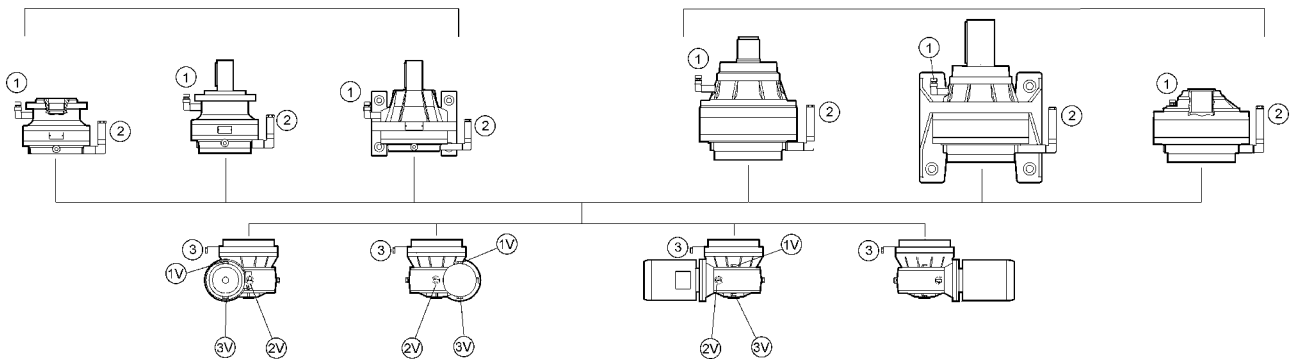

300 - 321 , 310M - 318M

T - V

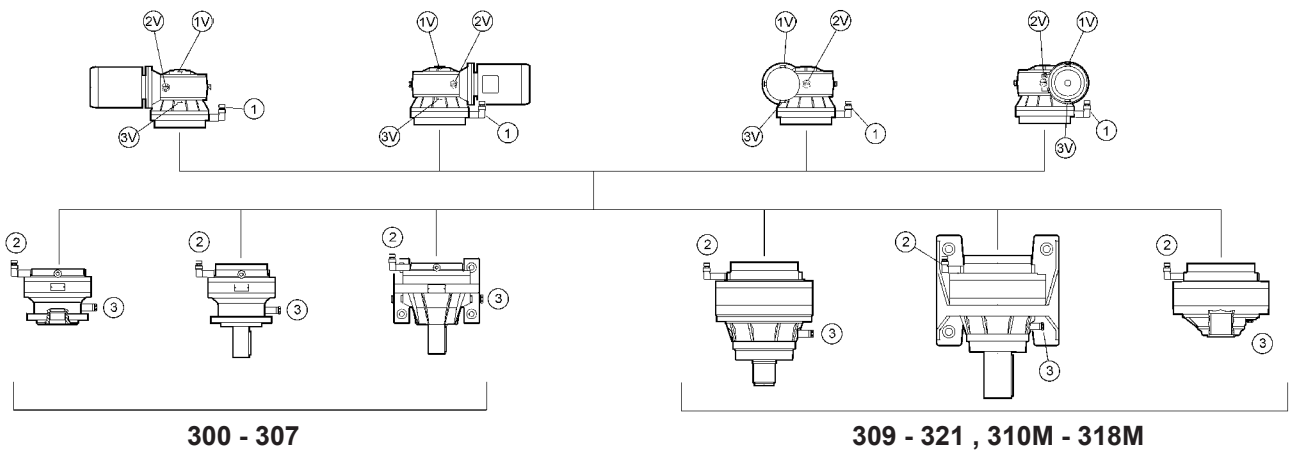



3/A Series

ALL GEARBOXES

(planetary stages)

- 1 Filling/breather oil plug
- 2 Oil level plug
- 3 Oil draining plug

(helical bevel reduction module)

- 1A Filling/breather oil plug
- 2A Oil level plug
- 3A Oil draining plug

300 - 307 A - E

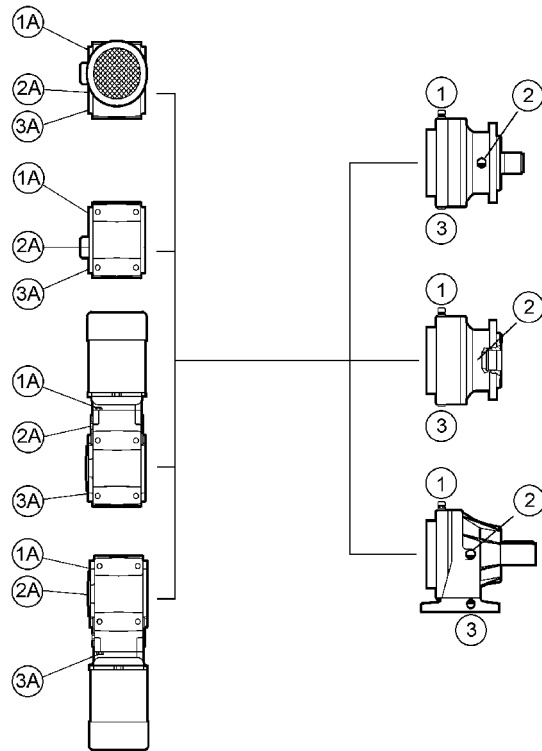

300 - 307 O - Q

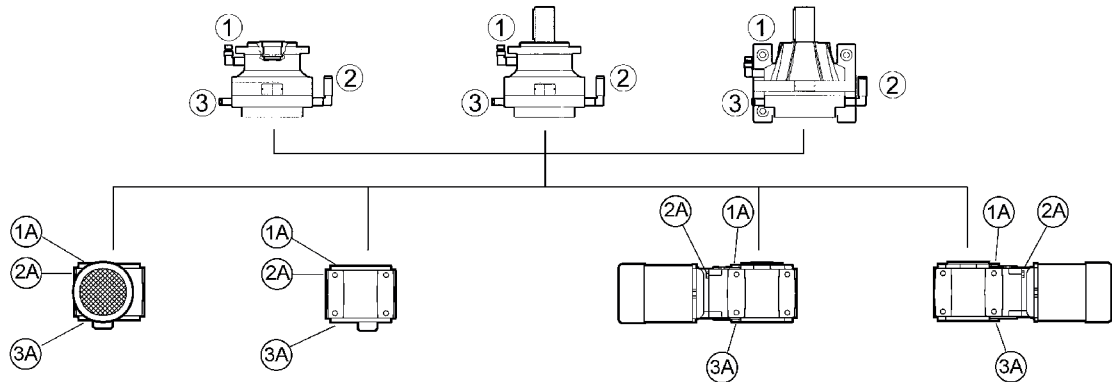

300 - 307 T - V

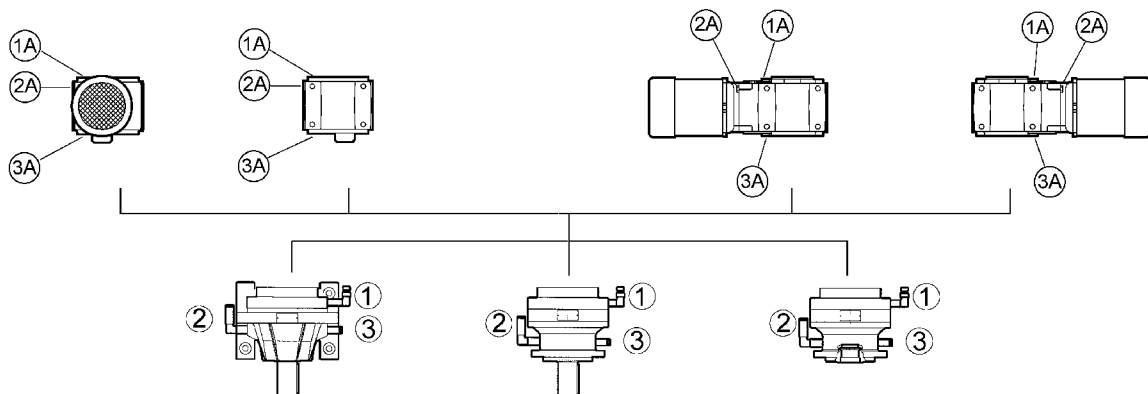

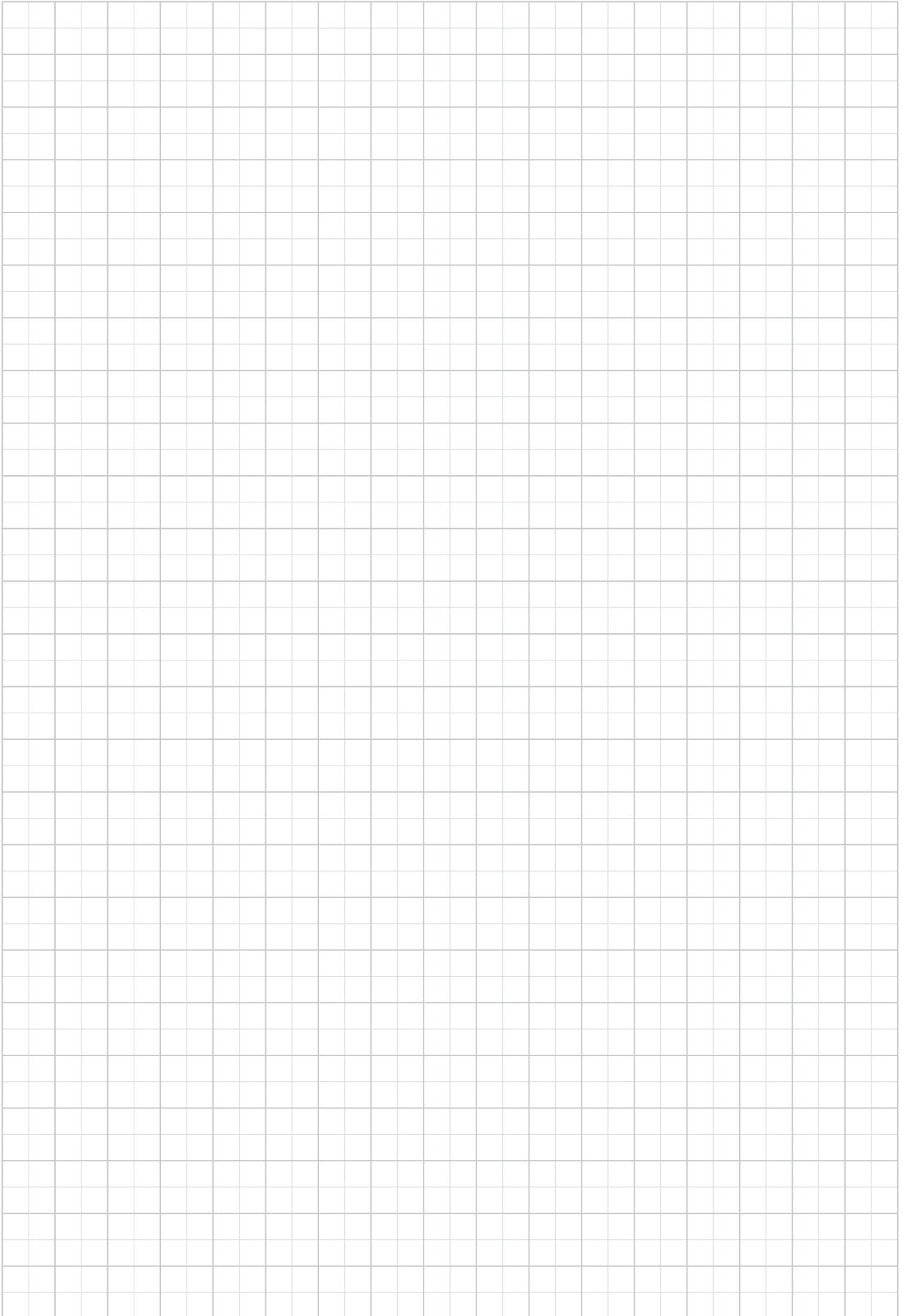



INDEX OF REVISIONS (R)

BR_IOM_300_ATX-INC_ENG_R05_1	
	Description
18, 19 36...38	Added information about the LONG TERM STOCK option.
21	Updated information for 309...321 , 310M...318M gear units - male output shaft execution.
24	Updated information for the installation of shaft mounting gear units.
27	Added information for the installation for gear units supplied without motor connection.
41	Updated table for routine maintenance.

2022.09.30

We reserve the right to implement modifications without notice.
This catalogue cannot be reproduced, even partially, without prior consent.



We have a relentless commitment to excellence, innovation & sustainability. Our team creates, distributes and services world-class power transmission & drive solutions to keep the world in motion.

HEADQUARTERS

Bonfiglioli S.p.A

Registered office: Via Cav. Clementino Bonfiglioli, 1
40012 Calderara di Reno - Bologna (Italy)
Tel. +39 051 6473111

Head office: Via Isonzo, 65/67/69
40033 Casalecchio di Reno - Bologna (Italy)

