



# 3/H SERIES

Combined gearboxes

 **Bonfiglioli**





# 3/H SERIES

## CONTENTS

---

COMBINED GEARBOXES - SPECIFICATIONS .....	4
FIELDS OF APPLICATION .....	5
PRODUCT OVERVIEW .....	6
VARIANTS.....	7
OPTIONS - ACCESSORIES .....	8
SPECIAL SOLUTIONS.....	9
DIMENSIONS.....	10
RATING TABLES.....	11
OUR CONSTANT AMBITION .....	16
OUR GLOBAL PRESENCE.....	18

# COMBINED GEARBOXES - SPECIFICATIONS

Bonfiglioli's 3/H gearboxes combine the high technology, performance and efficiency of planetary gearboxes with the robustness, quality and reliability of bevel helical gearboxes.

These planetary/bevel helical combination gearboxes deliver the high transmissible torque of our 300 Series along with the excellent power transmission characteristics of our HDO Series and are ideal for applications that demand high power density along with medium-low output speeds.

The 3/H range consists of 10 standard catalogue sizes that can transmit up to 1200 kNm of torque. Custom combinations are also available to order. A wide choice of gear ratios and above all the availability of numerous intermediate sizes enables the 3/H range to offer a truly complete answer to the needs of target applications.

Compared to conventional gearboxes, the flexibility and synergy of 3/H combination gearboxes guarantees significant benefits in terms of:

- Torque range
- Thermal capacity
- Compactness
- Silent running
- Versatility in solutions and accessories

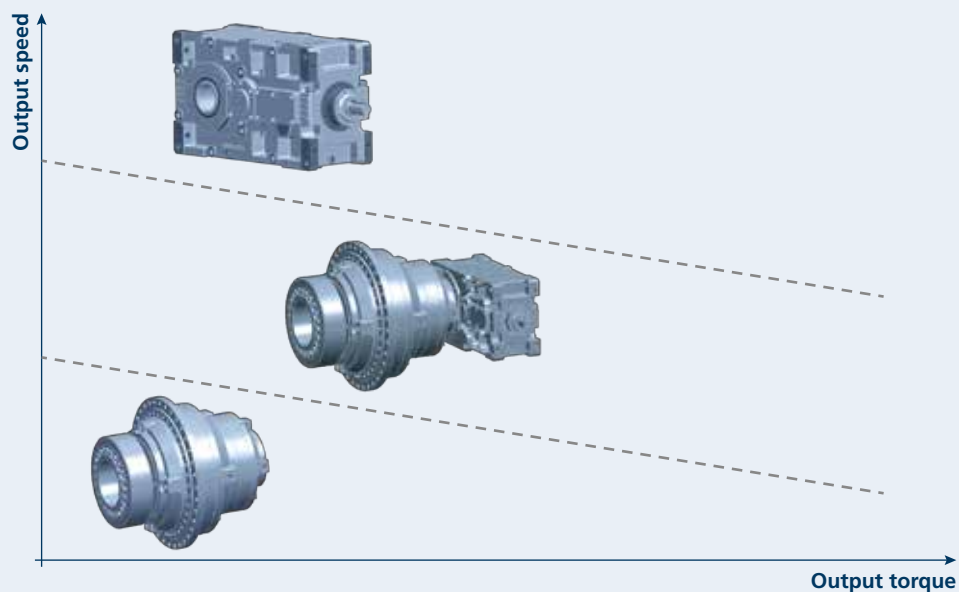

# FIELDS OF APPLICATION

---

3/H combined gearboxes are specially designed for use in high power applications in industries like mining, metal, paper and sugar.



**MINING INDUSTRY**



**METAL INDUSTRY**



**SUGAR INDUSTRY**



**PAPER INDUSTRY**

# PRODUCT OVERVIEW

## PRODUCT RANGE

Numerous combinations cover a wide range of applications and offer:

- Gear ratios from 1:100 to 1:1000
- Rated power up to 980 kW
- Reference torque up to 1200 kNm

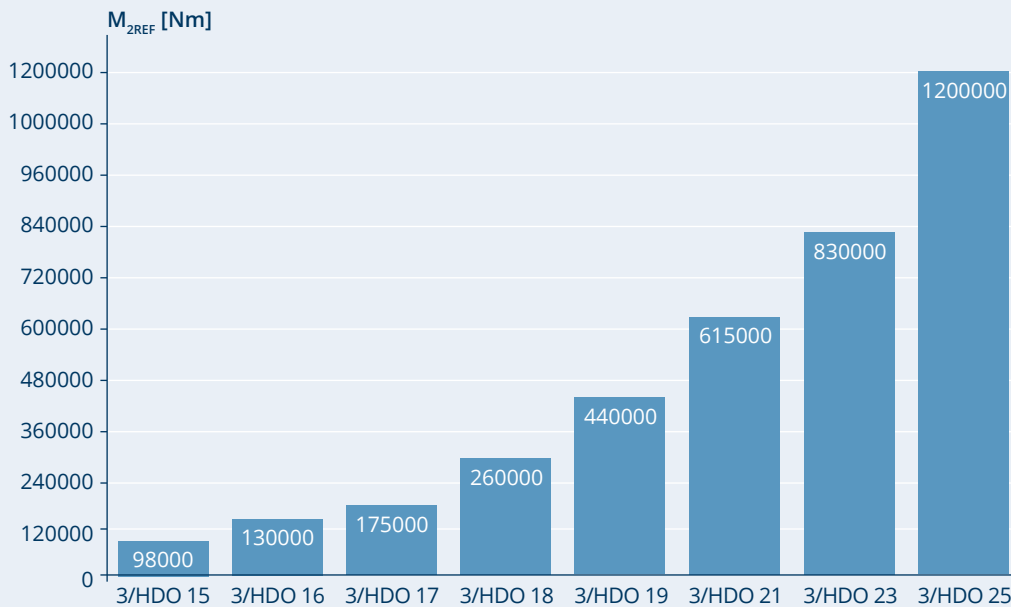

## SIZES AND GEAR RATIOS

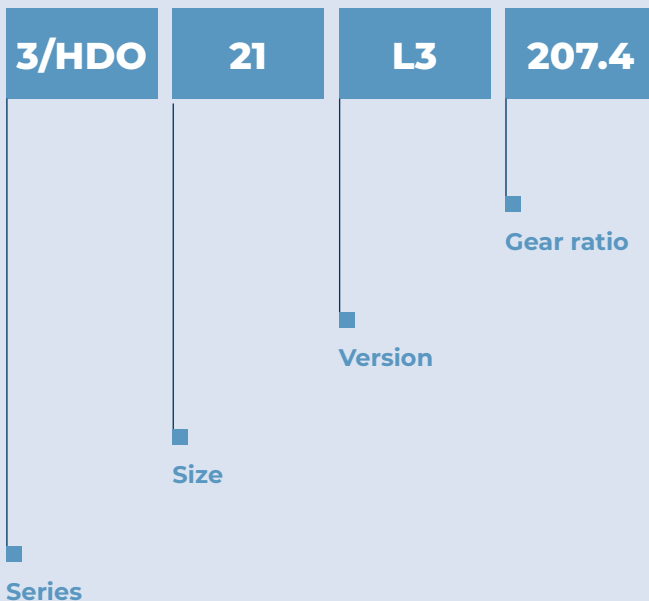

# VARIANTS

---

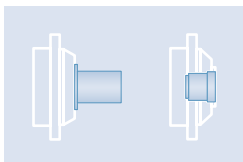

## OUTPUT VERSIONS

- solid cylindrical shaft
- solid shaft with keyway
- solid shaft with supporting feet
- solid shaft with keyway and supporting feet
- hollow shaft with shrink disc
- hollow shaft with keyway

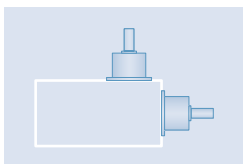

## INPUT VERSIONS

- Single sided cylindrical shaft
- Flange with motor coupling bell and intermediary elastic joint between the cylindrical shafts of the motor and gearbox.

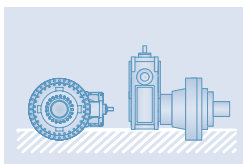

## MOUNTING POSITION

- Horizontal input shaft
- Vertical input shaft

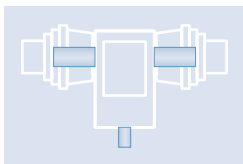

## SHAFT ARRANGEMENT

Depending on the needs of the application, 3/HDO combination gearboxes can be supplied with output shafts on the left or right side.

# OPTIONS - ACCESSORIES

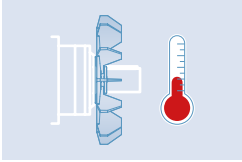

## AUXILIARY THERMAL DEVICES

The heat dissipation of 3/HDO combination gearboxes can be improved by the addition of devices like:

- cooling fans keyed on to the shaft
- integrated cooling circuit with heat exchange coil
- autonomous cooling units
- electrical heating elements if very low ambient temperatures make it necessary to pre-heat the lubricant in the casing before start-up and/or during operation.



## FORCED LUBRICATION

Standard lubrication is based on a splash system, but forced lubrication can be provided for use in special applications based on:

- forced lubrication circuits with mechanically driven pumps keyed on to the intermediate shaft of the bevel-helical unit (typical solution for continuous duty)
- forced lubrication circuits with independently powered pumps (typical solution per intermittent duty)

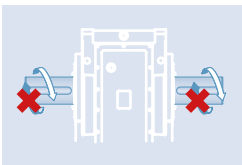

## BACKSTOP DEVICE

The backstop device ensures that the gearbox only turns in one direction, and prevents reverse movement caused by the load connected to the output shaft.

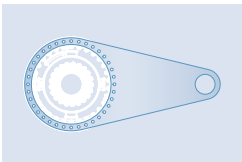

## TORQUE ARM

A torque arm is essential in all shaft mounted applications. The Bonfiglioli catalogue contains a wide range of standard torque arms for use with combination gearboxes.

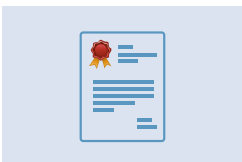

## CERTIFICATION

The following documents are available:

- Declaration of conformity
- Test certificate



# SPECIAL SOLUTIONS

---

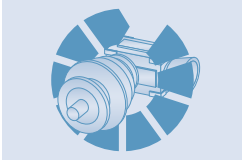

Special, complete and custom power transmission solutions are available for specific applications involving:

- **Torque arms**

The design of this accessory generally depends on the customer's machine. In addition to a standard offering, Bonfiglioli can also supply made to measure torque arms for specific applications.

- **Base plates**

Depending on the weight of the motor and/or the number of accessories needed for the combination gearbox, it may prove necessary to install a base plate. Base plate configuration depends on the overall weight of the assembled gearbox, motor and accessories.

- **Fluid couplings**

Fluid couplings are available in different versions and with different options. They are particularly useful in applications involving the acceleration of high inertia loads and/or a large number of starts per hour.

- **Shoe brakes**

- **Other accessories**

A wide range of other accessories is available to satisfy customer and application needs. Options include paint coatings for different kinds of corrosive environment, special seals and motor flanges with integrated fans.

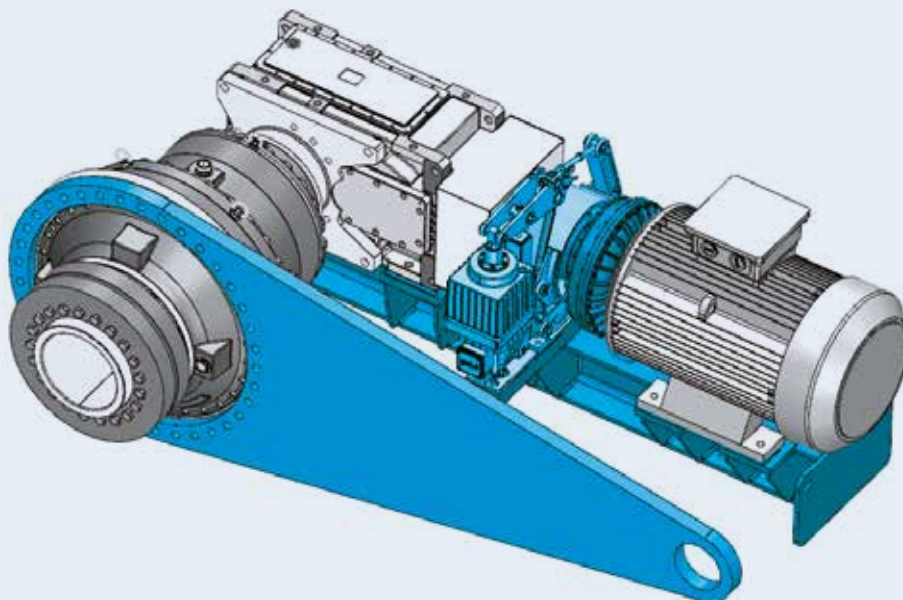

# DIMENSIONS

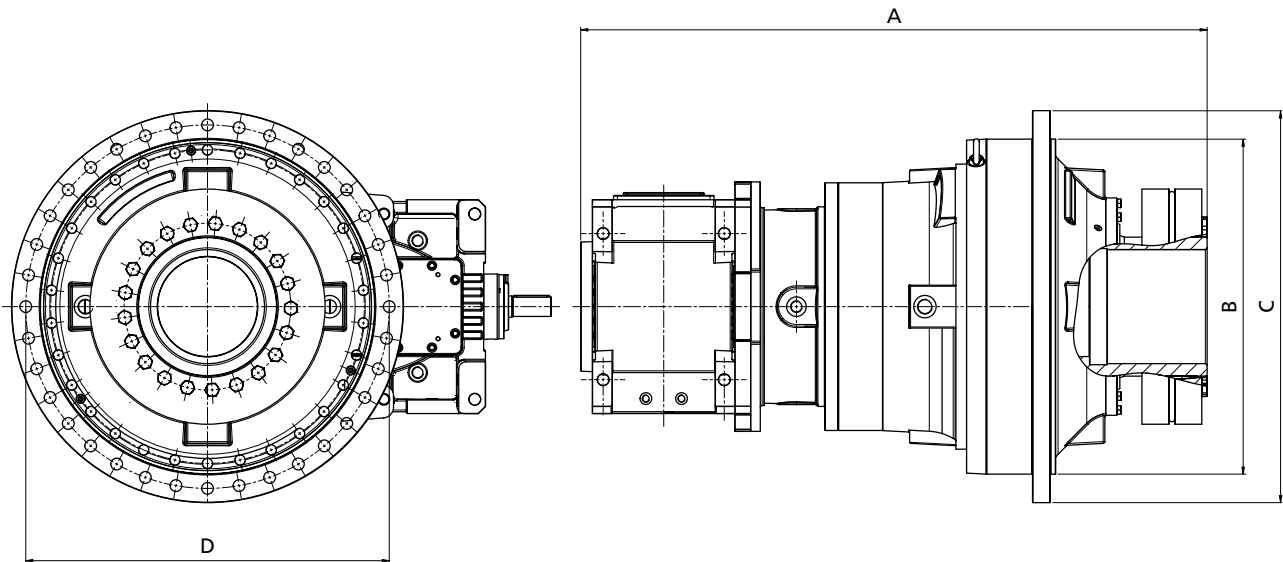

Size	A	B	C	D
	[mm]			
3/HDO 15 L2	1025	460	640	600
3/HDO 16 L2	1075	580	670	625
3/HDO 17 L2	1204	560	695	635
3/HDO 18 L2	1364	700	800	750
3/HDO 19 L2	1512	800	940	880
3/HDO 18 L3	1452	700	800	750
3/HDO 19 L3	1599	800	940	880
3/HDO 21 L3	1758	940	1100	1020
3/HDO 23 L3	2072	1100	1300	1220
3/HDO 25 L3	2125	1260	1460	1380

Note

For detailed overall dimensions and input and output dimensions, contact Bonfiglioli's Technical Service.

# RATING TABLES

3/HDO 15 L2			n <sub>1</sub> [min <sup>-1</sup> ] 1800			n <sub>1</sub> [min <sup>-1</sup> ] 1500				
Pre-stage	Output stage	Ratio	n <sub>2</sub> [min <sup>-1</sup> ]	M <sub>n2</sub> [Nm]	P <sub>n1</sub> [kW]	n <sub>2</sub> [min <sup>-1</sup> ]	M <sub>n2</sub> [Nm]	P <sub>n1</sub> [kW]	M <sub>n2 max</sub> [Nm]	M <sub>2 max</sub> [Nm]
HDO 100 3	315 L1	95,6	18,8	58620	127	15,7	61920	112	95210	135000
		106,3	16,9	60510	118	14,1	63910	104	95130	
		120,3	15,0	62800	108	12,5	66330	95	95520	
		133,9	13,4	64850	100	11,2	68500	88	95380	
		153,0	11,8	67500	91	9,8	71300	80	94290	
		170,0	10,6	69670	85	8,8	73590	75	93970	
		186,6	9,6	71640	80	8,0	75670	70	94920	
		207,4	8,7	73950	74	7,2	78110	65	96240	
		237,2	7,6	76990	67	6,3	81320	59	97580	
263,5		6,8	79460	62	5,7	83930	55	97920		
286,9		6,3	81510	59	5,2	86100	52	92940		
300,9		6,0	81630	56	5,0	86220	49	97530		
334,5		5,4	80560	50	4,5	85090	44	97670		
382,5		4,7	80460	44	3,9	84980	38	97770		
425,0		4,2	89400	44	3,5	94430	38	97680		
473,5		3,8	83870	37	3,2	88580	32	97560		
526,2		3,4	93190	37	2,9	98120	32	98120		
594,2		3,0	90230	31	2,5	95300	28	98190		
680,0	2,6	85540	26	2,2	90350	23	97600			
757,4	2,4	84470	23	2,0	89220	20	97920			
841,5	2,1	93470	23	1,8	98100	20	98100			
950,7	1,9	90430	20	1,6	95510	17	98670			

3/HDO 16 L2			n <sub>1</sub> [min <sup>-1</sup> ] 1800			n <sub>1</sub> [min <sup>-1</sup> ] 1500				
Pre-stage	Output stage	Ratio	n <sub>2</sub> [min <sup>-1</sup> ]	M <sub>n2</sub> [Nm]	P <sub>n1</sub> [kW]	n <sub>2</sub> [min <sup>-1</sup> ]	M <sub>n2</sub> [Nm]	P <sub>n1</sub> [kW]	M <sub>n2 max</sub> [Nm]	M <sub>2 max</sub> [Nm]
HDO 110 3	316 L1	93,5	19,3	74610	165	16,0	78810	145	120370	160000
		104,6	17,2	75670	150	14,3	79920	132	115220	
		115,6	15,6	80050	143	13,0	84550	126	122020	
		131,3	13,7	79920	126	11,4	84410	111	116660	
		145,8	12,3	85160	121	10,3	89950	107	123460	
		167,0	10,8	83600	104	9,0	88300	91	117900	
		185,3	9,7	89180	100	8,1	94190	88	124700	
		204,0	8,8	91160	93	7,4	96270	81	116660	
		225,7	8,0	97130	89	6,6	102590	78	123460	
259,3		6,9	90220	72	5,8	95290	63	117900		
286,9		6,3	99950	72	5,2	105560	64	124700		
329,4		5,5	108870	68	4,6	113580	60	113580		
329,0		5,5	89190	56	4,6	94200	49	116660		
364,2		4,9	98800	56	4,1	104350	49	124160		
411,0		4,4	87400	44	3,6	92320	39	115220		
462,8		3,9	97380	44	3,2	102860	38	124700		
517,2		3,5	91630	37	2,9	96780	32	116660		
582,7		3,1	86620	31	2,6	91490	27	130670		
657,5	2,7	93290	29	2,3	98530	26	127380			
740,8	2,4	95950	27	2,0	101350	24	130690			
827,5	2,2	98400	25	1,8	103930	22	128820			
916,7	2,0	104980	24	1,6	110880	21	130910			

Legend:

M<sub>n2</sub> [Nm] = rated torque for a duration of 10000 h

M<sub>n2 max</sub> [Nm] = maximum continuously transmissible torque

M<sub>2 max</sub> [Nm] = the output torque the gearbox can withstand under static or almost static conditions.

The value may change depending on the output versions.



# RATING TABLES

3/HDO 17 L2			n <sub>1</sub> [min <sup>-1</sup> ] 1800			n <sub>1</sub> [min <sup>-1</sup> ] 1500				
Pre-stage	Output stage	Ratio	n <sub>2</sub> [min <sup>-1</sup> ]	M <sub>n2</sub> [Nm]	P <sub>n1</sub> [kW]	n <sub>2</sub> [min <sup>-1</sup> ]	M <sub>n2</sub> [Nm]	P <sub>n1</sub> [kW]	M <sub>n2 max</sub> [Nm]	M <sub>2 max</sub> [Nm]
HDO 120 3	317 L1	102,4	17,6	113680	230	14,7	120070	202	147940	240000
		114,5	15,7	117470	213	13,1	124080	187	147510	
		129,2	13,9	121440	195	11,6	128270	171	147390	
		148,6	12,1	118870	166	10,1	125550	146	148030	
		168,0	10,7	131390	162	8,9	138780	143	147790	
		182,7	9,9	133440	151	8,2	140940	133	145730	
		216,3	8,3	139980	134	6,9	147290	118	147290	
		236,3	7,6	142270	125	6,3	148200	110	148200	
		259,9	6,9	129840	103	5,8	137140	91	149400	
		283,5	6,3	141400	103	5,3	149350	91	150210	
HDO 120 4		336,0	5,4	154790	97	4,5	154790	85	154790	
		365,4	4,9	158730	92	4,1	158730	81	158730	
		412,7	4,4	161180	87	3,6	161180	76	161180	
		456,8	3,9	123890	56	3,3	130860	49	162650	
		540,8	3,3	134230	51	2,8	141780	45	167440	
		589,6	3,1	146180	51	2,5	154390	45	171840	
		659,9	2,7	135330	42	2,3	142940	37	173910	
		718,7	2,5	145190	42	2,1	153350	37	174520	
		851,6	2,1	147130	36	1,8	155400	31	175690	
		943,4	1,9	140230	31	1,6	148120	27	179230	

3/HDO 18 L2			n <sub>1</sub> [min <sup>-1</sup> ] 1800			n <sub>1</sub> [min <sup>-1</sup> ] 1500				
Pre-stage	Output stage	Ratio	n <sub>2</sub> [min <sup>-1</sup> ]	M <sub>n2</sub> [Nm]	P <sub>n1</sub> [kW]	n <sub>2</sub> [min <sup>-1</sup> ]	M <sub>n2</sub> [Nm]	P <sub>n1</sub> [kW]	M <sub>n2 max</sub> [Nm]	M <sub>2 max</sub> [Nm]
HDO 130 3	318 L1	99,4	18,1	152630	318	15,1	161150	280	232060	320000
		108,7	16,6	156750	299	13,8	165510	263	230450	
		124,5	14,5	163280	272	12,0	172400	239	228000	
		136,0	13,2	167640	255	11,0	177010	225	230040	
		153,6	11,7	173880	235	9,8	183590	206	230300	
		168,5	10,7	178800	220	8,9	188790	193	228430	
		192,7	9,3	186140	200	7,8	196540	176	229250	
		210,3	8,6	191090	188	7,1	201760	166	226700	
		237,6	7,6	191390	167	6,3	202150	147	226360	
		259,6	6,9	203540	162	5,8	214910	143	232450	
HDO 130 4		295,2	6,1	211550	148	5,1	223370	131	236970	
		314,6	5,7	206400	136	4,8	218000	120	236870	
		343,6	5,2	221410	133	4,4	233780	117	238480	
		388,1	4,6	229640	123	3,9	242470	108	242470	
		423,7	4,2	235770	115	3,5	248940	101	248940	
		489,3	3,7	246170	104	3,1	254750	92	254750	
		534,2	3,4	252740	98	2,8	256290	86	256290	
		621,7	2,9	236170	79	2,4	249450	69	262780	
		678,9	2,7	257810	79	2,2	262870	69	262870	
		766,9	2,3	262740	76	2,0	262740	67	262740	
		837,3	2,1	262710	72	1,8	262710	63	262710	
		964,0	1,9	256940	55	1,6	263370	49	263370	

Legend:

M<sub>n2</sub> [Nm] = rated torque for a duration of 10000 h

M<sub>n2 max</sub> [Nm] = maximum continuously transmissible torque

M<sub>2 max</sub> [Nm] = the output torque the gearbox can withstand under static or almost static conditions.

The value may change depending on the output versions.



# RATING TABLES

3/HDO 18 L3			n <sub>1</sub> [min <sup>-1</sup> ] 1800			n <sub>1</sub> [min <sup>-1</sup> ] 1500				
Pre-stage	Output stage	Ratio	n <sub>2</sub> [min <sup>-1</sup> ]	M <sub>n2</sub> [Nm]	P <sub>n1</sub> [kW]	n <sub>2</sub> [min <sup>-1</sup> ]	M <sub>n2</sub> [Nm]	P <sub>n1</sub> [kW]	M <sub>n2 max</sub> [Nm]	M <sub>2 max</sub> [Nm]
HDO 100 2	318 L2	108,5	16,6	156640	299	13,8	165570	263	230540	50000
		121,6	14,8	162090	276	12,3	171330	243	230540	
		130,9	13,8	165730	262	11,5	175180	231	227670	
		149,6	12,0	172510	239	10,0	182340	210	228730	
		162,7	11,1	176900	225	9,2	186990	198	230390	
		187,0	9,6	184450	204	8,0	194960	180	227410	
		203,8	8,8	189280	192	7,4	200070	169	229060	
		231,9	7,8	196750	176	6,5	207960	155	229280	
		252,5	7,1	201830	166	5,9	213330	146	226780	
		291,4	6,2	210490	150	5,1	223190	132	227660	
HDO 100 3	318 L2	317,3	5,7	215920	141	4,7	228950	125	229070	50000
		329,0	5,5	218290	137	4,6	231460	121	231590	
		366,6	4,9	225490	127	4,1	234600	113	234600	
		406,6	4,4	232600	119	3,7	242000	105	242000	
		474,7	3,8	243670	106	3,2	243670	94	243670	
		528,8	3,4	251680	99	2,8	251680	87	251680	
		587,5	3,1	254600	92	2,6	254600	81	254600	
		665,1	2,7	258930	84	2,3	258930	74	258930	
		740,3	2,4	261960	78	2,0	261960	69	261960	
		846,0	2,1	263750	71	1,8	263750	63	263750	
940,0	1,9	264290	66	1,6	264290	58	264290			

3/HDO 19 L2			n <sub>1</sub> [min <sup>-1</sup> ] 1800			n <sub>1</sub> [min <sup>-1</sup> ] 1500				
Pre-stage	Output stage	Ratio	n <sub>2</sub> [min <sup>-1</sup> ]	M <sub>n2</sub> [Nm]	P <sub>n1</sub> [kW]	n <sub>2</sub> [min <sup>-1</sup> ]	M <sub>n2</sub> [Nm]	P <sub>n1</sub> [kW]	M <sub>n2 max</sub> [Nm]	M <sub>2 max</sub> [Nm]
HDO 130 3	319 L1	89,1	20,2	197230	458	16,8	208320	403	290750	40000
		96,9	18,6	212500	454	15,5	227410	405	309930	
		110,1	16,4	207510	391	13,6	219170	344	281780	
		120,3	15,0	226530	390	12,5	239260	343	305510	
		137,8	13,1	229320	345	10,9	242210	303	318940	
		150,5	12,0	238320	328	10,0	251710	289	306290	
		170,0	10,6	225190	274	8,8	237850	242	317240	
		186,5	9,7	220630	245	8,0	233040	216	287210	
		213,3	8,4	224140	218	7,0	236740	192	307760	
		232,8	7,7	234120	208	6,4	247280	183	303140	
HDO 130 4	319 L1	263,0	6,8	211840	167	5,7	223750	147	314190	40000
		287,3	6,3	231250	167	5,2	244250	147	301870	
		326,8	5,5	263130	167	4,6	277920	147	304960	
		348,2	5,2	228450	136	4,3	241290	120	313630	
		380,3	4,7	249380	136	3,9	263400	120	301310	
		429,5	4,2	281750	136	3,5	297590	120	320050	
		469,0	3,8	301410	133	3,2	316110	117	316110	
		541,5	3,3	273140	104	2,8	288500	92	331410	
		591,2	3,0	298180	104	2,5	314940	92	318490	
		688,1	2,6	261400	79	2,2	276090	69	343780	
751,4	2,4	285350	79	2,0	301390	69	330490			
848,8	2,1	322390	79	1,8	340510	69	355230			
926,8	1,9	341570	79	1,6	341570	69	341570			

Legend:

M<sub>n2</sub> [Nm] = rated torque for a duration of 10000 h

M<sub>n2 max</sub> [Nm] = maximum continuously transmissible torque

M<sub>2 max</sub> [Nm] = the output torque the gearbox can withstand under static or almost static conditions.

The value may change depending on the output versions.

Contact Bonfiglioli's Technical Service.



# RATING TABLES

3/HDO 19 L3			n <sub>1</sub> [min <sup>-1</sup> ] 1800			n <sub>1</sub> [min <sup>-1</sup> ] 1500				
Pre-stage	Output stage	Ratio	n <sub>2</sub> [min <sup>-1</sup> ]	M <sub>n2</sub> [Nm]	P <sub>n1</sub> [kW]	n <sub>2</sub> [min <sup>-1</sup> ]	M <sub>n2</sub> [Nm]	P <sub>n1</sub> [kW]	M <sub>n2 max</sub> [Nm]	M <sub>2 max</sub> [Nm]
HDO 100 2	319 L2	120,1	15,0	184500	318	12,5	194870	280	381950	68000
		134,6	13,4	190910	294	11,1	201650	259	384020	
		144,9	12,4	195200	279	10,4	206180	246	381350	
		165,6	10,9	203180	254	9,1	214610	224	385350	
		180,1	10,0	208360	240	8,3	220080	211	383460	
		207,0	8,7	217250	217	7,2	229470	191	381860	
		225,6	8,0	222940	205	6,6	235480	180	382590	
		256,7	7,0	231730	187	5,8	244760	165	385630	
279,5		6,4	237720	176	5,4	251080	155	389480		
289,8		6,2	240320	172	5,2	253840	151	387620		
322,9		5,6	248250	159	4,6	262210	140	394130		
358,1		5,0	256080	148	4,2	270480	130	406550		
418,1		4,3	268270	133	3,6	283350	117	412490		
465,8		3,9	277090	123	3,2	292670	108	428500		
517,5		3,5	285990	114	2,9	302070	101	434980		
585,8		3,1	296820	105	2,6	313510	92	443970		
652,1	2,8	306520	97	2,3	323750	86	442460			
745,2	2,4	319050	89	2,0	336990	78	443700			
828,0	2,2	329290	82	1,8	347810	73	443460			
908,7	2,0	338610	77	1,7	357650	68	447070			
1010,2	1,8	349530	72	1,5	369190	63	442740			

3/HDO 21 L3			n <sub>1</sub> [min <sup>-1</sup> ] 1800			n <sub>1</sub> [min <sup>-1</sup> ] 1500				
Pre-stage	Output stage	Ratio	n <sub>2</sub> [min <sup>-1</sup> ]	M <sub>n2</sub> [Nm]	P <sub>n1</sub> [kW]	n <sub>2</sub> [min <sup>-1</sup> ]	M <sub>n2</sub> [Nm]	P <sub>n1</sub> [kW]	M <sub>n2 max</sub> [Nm]	M <sub>2 max</sub> [Nm]
HDO 120 2	321 L2	120,1	15,0	310570	536	12,5	328030	471	519220	80000
		131,0	13,7	318780	504	11,4	336710	444	544880	
		153,8	11,7	334600	451	9,8	352870	396	560220	
		167,8	10,7	343450	424	8,9	362200	373	556920	
		188,7	9,5	355800	390	7,9	375230	343	558490	
		207,4	8,7	366000	366	7,2	385980	321	555820	
		233,0	7,7	379020	337	6,4	399720	296	556570	
		258,6	7,0	391070	313	5,8	412430	275	564580	
291,3		6,2	405260	288	5,2	427390	253	565230		
319,2		5,6	416560	270	4,7	439310	238	580990		
361,2		5,0	432280	248	4,2	455880	218	592470		
403,1		4,5	446760	230	3,7	471160	202	601620		
454,4		4,0	463100	211	3,3	488390	186	612630		
507,9		3,5	478850	195	3,0	505000	172	614420		
573,2		3,1	496530	179	2,6	523640	158	615280		
659,4		2,7	511250	161	2,3	539990	141	614390		
745,6	2,4	537290	149	2,0	566630	131	613850			
810,8	2,2	550980	141	1,8	581070	124	614960			
960,0	1,9	579610	125	1,6	611260	110	616350			

Legend:

$M_{n2}$  [Nm] = rated torque for a duration of 10000 h

$M_{n2 max}$  [Nm] = maximum continuously transmissible torque

$M_{2 max}$  [Nm] = the output torque the gearbox can withstand under static or almost static conditions.

The value may change depending on the output versions.



Contact Bonfiglioli's Technical Service.



# RATING TABLES

3/HDO 23 L3			n <sub>1</sub> [min <sup>-1</sup> ] 1800			n <sub>1</sub> [min <sup>-1</sup> ] 1500				
Pre-stage	Output stage	Ratio	n <sub>2</sub> [min <sup>-1</sup> ]	M <sub>n2</sub> [Nm]	P <sub>n1</sub> [kW]	n <sub>2</sub> [min <sup>-1</sup> ]	M <sub>n2</sub> [Nm]	P <sub>n1</sub> [kW]	M <sub>n2 max</sub> [Nm]	M <sub>2 max</sub> [Nm]
HDO 130 2	323 L2	121,5	14,8	551670	940	12,3	583160	828	812000	150000
		139,2	12,9	574570	855	10,8	607360	753	803240	
		150,9	11,9	588730	808	9,9	622330	712	808780	
		172,5	10,4	612790	736	8,7	647760	648	812560	
		188,2	9,6	629000	692	8,0	664900	610	804520	
		215,6	8,3	655210	629	7,0	692610	554	807860	
235,2		7,7	672540	592	6,4	710930	522	798800		
266,6		6,8	698280	543	5,6	738130	478	813790		
HDO 130 3		297,9	6,0	721970	502	5,0	763180	442	825450	
		358,7	5,0	763310	441	4,2	806880	388	833770	
		390,0	4,6	782750	416	3,8	827420	366	834320	
		443,0	4,1	809320	378	3,4	830960	333	830960	
		484,1	3,7	831340	357	3,1	831340	315	831340	
		554,7	3,2	835320	325	2,7	835320	286	835320	
		605,6	3,0	834040	305	2,5	834040	269	834040	
		684,0	2,6	832410	266	2,2	832410	234	832410	
		750,7	2,4	830780	237	2,0	830780	209	830780	
		858,5	2,1	838700	211	1,7	838700	186	838700	
	936,9	1,9	831460	202	1,6	831460	178	831460		

3/HDO 25 L3			n <sub>1</sub> [min <sup>-1</sup> ] 1800			n <sub>1</sub> [min <sup>-1</sup> ] 1500				
Pre-stage	Output stage	Ratio	n <sub>2</sub> [min <sup>-1</sup> ]	M <sub>n2</sub> [Nm]	P <sub>n1</sub> [kW]	n <sub>2</sub> [min <sup>-1</sup> ]	M <sub>n2</sub> [Nm]	P <sub>n1</sub> [kW]	M <sub>n2 max</sub> [Nm]	M <sub>2 max</sub> [Nm]
HDO 130 2	325 L2	138,9	13,0	660140	985	10,8	697260	867	1196790	175000
		159,0	11,3	683840	891	9,4	722290	784	1196600	
		172,5	10,4	707890	850	8,7	747690	748	1194150	
		197,1	9,1	732910	770	7,6	774110	678	1196430	
		215,0	8,4	742730	715	7,0	784490	630	934590	
		246,4	7,3	770290	648	6,1	813600	570	1201090	
268,8		6,7	780780	602	5,6	824670	530	1196380		
304,6		5,9	810830	551	4,9	856420	485	1196710		
HDO 130 3		340,5	5,3	850670	517	4,4	898490	455	1198160	
		409,9	4,4	879150	444	3,7	928580	391	1200530	
		445,8	4,0	959720	446	3,4	1013670	393	1197140	
		506,2	3,6	924940	378	3,0	976940	333	1199610	
		553,3	3,3	1009700	378	2,7	1066470	333	1204840	
		633,9	2,8	1022180	334	2,4	1079650	294	1198420	
		692,2	2,6	1062270	318	2,2	1121990	280	1201380	
		781,8	2,3	1003750	266	1,9	1060180	234	1205860	
		857,9	2,1	983460	237	1,7	1038750	209	1201760	
		981,1	1,8	999070	211	1,5	1055240	186	1200270	
	1070,7	1,7	1043550	202	1,4	1102220	178	1211270		

Legend:

M<sub>n2</sub> [Nm] = rated torque for a duration of 10000 h

M<sub>n2 max</sub> [Nm] = maximum continuously transmissible torque

M<sub>2 max</sub> [Nm] = the output torque the gearbox can withstand under static or almost static conditions.

The value may change depending on the output versions.



Contact Bonfiglioli's Technical Service.



# OUR PROJECTION INTO THE FUTURE

---

MORE THAN 250 EMPLOYEES AROUND THE WORLD ARE INVOLVED IN THE GROUP'S R&D ACTIVITIES.

## DESIGN SIMULATION

Bonfiglioli has the most advanced **virtual simulation techniques** that allow to speed up the validation process, thus reducing time to market and providing customers with optimized and efficient solutions.



## TEST LABORATORIES

In our R&D department we **research, develop, validate and certify** all the products and solutions which are engineered and manufactured in our plants across the world.



## CO-ENGINEERING

At Bonfiglioli we **work close to our customers to satisfy all their needs** and requirements with a true tailormade solution.





# OUR CONSTANT AMBITION

---

QUALITY, HEALTH, SAFETY, ENVIRONMENT & ENERGY

## QUALITY: WE CARE ABOUT OUR CUSTOMERS

Our team is wholly dedicated to continuous improvement in the quality, safety, environmental and energy spheres throughout the entire value chain, from the smallest supplier to the end client. Bonfiglioli is committed to achieving the highest quality standards, and our products are intended to generate value for our customers while respecting both people and the environment. We design, manufacture and supply effective products and services that set a benchmark for quality in the industry.

Bonfiglioli management systems are certified ISO 9001: 2015, ISO 14001: 2015, ISO 45001: 2018 and ISO 50001:2018, while our products are covered by 7 international certifications. Responsibility, excellence and continuous improvement are the basic elements that make us the favored partner of our clients and suppliers.

## HEALTH & SAFETY: SUSTAINABILITY STARTS WITH SAFETY

Prevention of accidents and incidents is a key element of our company's sustainability strategy and an integral part of each one of our business processes. The successful management of risks is essential for protecting our employees and assets, thereby strengthening their contributions.

## ENVIRONMENT & ENERGY: RESPECT THE PRESENT TO BUILD THE FUTURE

At Bonfiglioli, we believe that respect for the present and the adoption of environmental protection and energy efficiency policies are essential if we are to enjoy a better future.



# OUR GLOBAL PRESENCE

---

Thanks to an international network of closely interconnected commercial and production sites, we can guarantee the same high standards of Bonfiglioli quality anywhere at any given time. We know that our direct presence in local markets is the key to long-lasting success, so our family includes 20 production sites, 26 commercial sites and more than 550 distributors around the world.

Our organization is always close by, offering complete and efficient solutions and supporting our customers with dedicated services, co-engineering and after-sales assistance.



**20**  
PRODUCTION SITES

**26**  
COMMERCIAL SITES

**80**  
COUNTRIES

**550**  
DISTRIBUTORS

**~4,800**  
PEOPLE

## AUSTRALIA

### Bonfiglioli Transmission (Aust.) Pty Ltd

2, Cox Place Glendenning NSW 2761  
Locked Bag 1000 Plumpton NSW 2761  
Tel. +61 2 8811 8000



## BRAZIL

### Bonfiglioli Redutores do Brasil Ltda

Av. Osvaldo Fregonezi, 171, cjs 31 e 44  
CEP 09851-015 - São Bernardo do Campo  
São Paulo  
Tel. +55 11 4344 2322



## CHINA

### Bonfiglioli Drives (Shanghai) Co. Ltd.

#68, Hui-Lian Road, QingPu District,  
201707 Shanghai  
Tel. +86 21 6700 2000



### Motion & Robotics

#568, Longpan Road, Jiading District,  
201707 Shanghai



### Bonfiglioli Trading (Shanghai) Co. Ltd.

Room 423, 4<sup>th</sup> Floor, #38, Yinglun Road,  
China (Shanghai) Pilot Free Trade Zone,  
Shanghai



### Selcom Electronics (Shanghai) Co., Ltd

A7, No.5399, Waiqingsong Road, QingPu  
District,  
201707 Shanghai  
Tel. +86 21 6010 8100



A24, No.5399, Waiqingsong Road, QingPu  
District,  
201707 Shanghai

Tel. +86 21 6010 8100



## FRANCE

### Bonfiglioli Transmission S.A.S.

14 Rue Eugène Pottier  
Zone Industrielle de Moimont II  
95670 Marly la Ville  
Tel. +33 1 34474510



## GERMANY

### Bonfiglioli Deutschland GmbH

Sperberweg 12 - 41468 Neuss  
Tel. +49 0 2131 2988 0



### Bonfiglioli Vectron GmbH

Europark Fichtenhain B6 - 47807 Krefeld  
Tel. +49 0 2151 8396 0



### O&K Antriebstechnik GmbH

Ruhrallee 8-12 - 45525 Hattingen  
Tel. +49 0 2324 2050 1



## INDIA

### Bonfiglioli Transmission Pvt. Ltd.

#### Mobility & Wind Industries

AC 7 - AC 11 Sidco Industrial Estate  
Thirumudivakkam Chennai - 600 044  
Tel. +91 844 844 8649



#### Discrete Manufacturing &

#### Process Industries - Motion & Robotics

Survey No. 528/1,  
Perambakkam High Road Mannur Village,  
Sriperumbudur Taluk Chennai - 602 105  
Tel. +91 844 844 8649



#### Discrete Manufacturing &

#### Process Industries

Plot No.A-9/5, Phase IV MIDC Chakan,  
Village Nighoje Pune - 410 501  
Tel. +91 844 844 8649



## ITALY

### Bonfiglioli Riduttori S.p.A.

#### Discrete Manufacturing & Process Industries

Via Cav. Clementino Bonfiglioli, 1  
40012 Calderara di Reno  
Tel. +39 051 6473111



#### Discrete Manufacturing &

#### Process Industries

Via Sandro Pertini, lotto 7b  
20080 Carpiano  
Tel. +39 02985081



#### Discrete Manufacturing &

#### Process Industries

Via Saliceto, 15 - 40010 Bentivoglio



#### Mobility & Wind Industries

Via Enrico Mattei, 12 Z.I. Villa Selva  
47122 Forlì  
Tel. +39 0543 789111



#### Motion & Robotics

Via Unione, 49 - 38068 Rovereto  
Tel. +39 0464 443435/36



### Selcom Group S.p.A.

Via Achille Grandi, 5  
40013 Castel Maggiore (BO)  
Tel. +39 051 6387111



Via Marino Serenari, 18  
40013 Castel Maggiore (BO)  
Tel. +39 051 6387111



Via Cadriano, 19  
40057 Cadriano (BO)  
Tel. +39 051 6387111



## NEW ZEALAND

### Bonfiglioli Transmission (Aust.) Pty Ltd

88 Hastie Avenue, Mangere Bridge,  
2022 Auckland  
PO Box 11795, Ellerslie  
Tel. +64 09 634 6441



## SINGAPORE

### Bonfiglioli South East Asia Pte Ltd

8 Boon Lay Way, #04-09,  
8@ Tadehub 21, Singapore 609964  
Tel. +65 6268 9869



## SLOVAKIA

### Bonfiglioli Slovakia s.r.o.

Robotnícka 2129  
Považská Bystrica, 01701 Slovakia  
Tel. +421 42 430 75 64



## SOUTH AFRICA

### Bonfiglioli South Africa Pty Ltd.

55 Galaxy Avenue, Linbro Business Park,  
Sandton, Johannesburg  
2090 South Africa  
Tel. +27 11 608 2030



## SPAIN

### Tecnotrans Bonfiglioli S.A

Avinguda del Ferrocarril, n° 14,  
Polígono Industrial Can Estapé  
08755 Castellbisbal - Barcelona  
Tel. +34 93 447 84 00



## TURKEY

### Bonfiglioli Turkey Jsc

Atatürk Organize Sanayi Bölgesi,  
10007 Sk. No. 30  
Atatürk Organize Sanayi Bölgesi,  
35620 Çiğli - İzmir  
Tel. +90 0 232 328 22 77



## UNITED KINGDOM

### Bonfiglioli UK Ltd.

Unit 1 Calver Quay, Calver Road, Winwick  
Warrington, Cheshire - WA2 8UD  
Tel. +44 1925 852667



## USA

### Bonfiglioli USA Inc.

3541 Hargrave Drive  
Hebron, Kentucky 41048  
Tel. +1 859 334 3333



## VIETNAM

### Bonfiglioli Vietnam Ltd.

Lot C-9D-CN My Phuoc Industrial Park 3  
Ben Cat - Binh Duong Province  
Tel. +84 650 3577411





We have a relentless commitment to excellence, innovation & sustainability. Our team creates, distributes and services world-class power transmission & drive solutions to keep the world in motion.

#### HEADQUARTERS

##### Bonfiglioli S.p.A

Via Cav. Clementino Bonfiglioli, 1  
40012 Calderara di Reno - Bologna (Italy)  
Tel. +39 051 6473111

