



CATALOGUE 1 | DRIVE CHAIN



Innovation in Motion
TSUBAKI

INTRODUCTION TO TSUBAKI ROLLER CHAIN

Glossary

1. Minimum Tensile Strength as per ISO Standardisation

This is the Minimum Tensile Strength determined by ISO. If a roller chain fails a tensile load below this value, it does not surpass the standards.

2. Minimum Tensile Strength as per TSUBAKI Standardisation

This is a minimum value determined by statistical processes at TSUBAKI. If a roller chain fractures at a tensile load below this value, it does not surpass TSUBAKI standards. TSUBAKI standards are higher than ISO standards.

3. Average Tensile Strength as per TSUBAKI Standardisation

This is a fracture load reading obtained after a long period of actual tensile strength testing of a large number of chain strands. Of course, when any given strand of roller chain fractures, this value may be higher or lower, so it does not represent a guaranteed value.

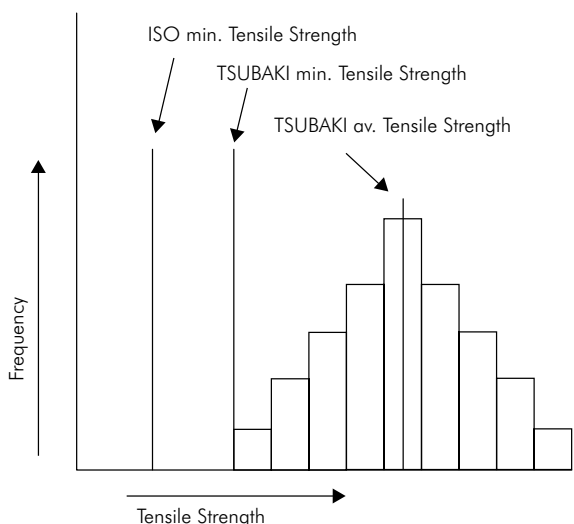

Fig. 1 Relationship between the three tensile strengths mentioned above.

4. Tensile Strength Testing Method

As shown in Fig. 2, a roller chain with minimum of five links is fixed at both ends by clevises and tensioned until fracture occurs. The type of fracture can be used to determine the cause of the breakage of the chain (Fig. 3).

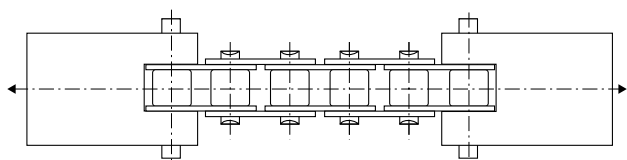

Fig. 2 Tensile Strength test

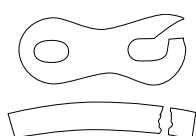

Fig. 3 Shape of fracture

5. Maximum Allowable Load

The Maximum Allowable Load (M.A.L.) of a roller chain (excluding Stainless Steel Chain and Engineering Plastic Chain) is the value derived from the lowest fatigue limit. When a load lower than this value is repetitively applied to the roller chain, fatigue failure will never occur.

The TSUBAKI M.A.L. is determined after 10 million repetitive loads instead of 3 million repetitive loads which is the European Standard.

The Maximum Allowable Load of Stainless Steel Chain and Engineering Plastic Chain is determined by the surface pressure between the pins and bushes.

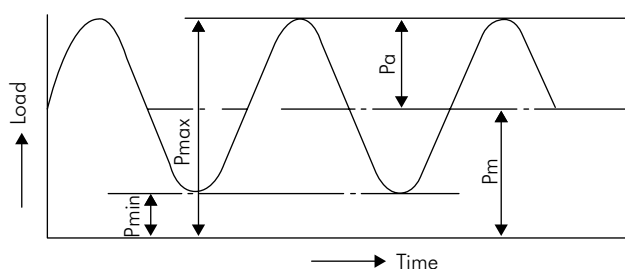

Fig. 4 Summary chart for repetitive loads

6. Ring Coining Process

For easy assembling the pin and link plate of a connecting link are slip fit. In general, this type of connecting link has a 20% lower fatigue strength than the chain itself. However, TSUBAKI developed a special process to eliminate that loss of fatigue strength and still satisfy the customers demand for easy assembling: the patented Ring Coining process. By applying the patented Ring Coining process, TSUBAKI generates a cold deformation around the pin hole of the connecting link plate. This results in residual stress around the pin hole and thereby adds strength. By using this process, transmission capacity is increased back to 100%.

TSUBAKI applies the patented Ring Coining process to all slip fit connecting links.

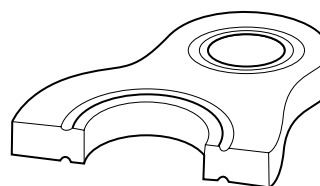

Fig. 5 Ring Coining

For severe conditions, TSUBAKI has developed the Heavy Duty Chain series. These chains are standard equipped with press fit connecting links. The installation is more difficult than in case of standard connecting links.

INTRODUCTION TO TSUBAKI ROLLER CHAIN

7. Ball Drifting Process

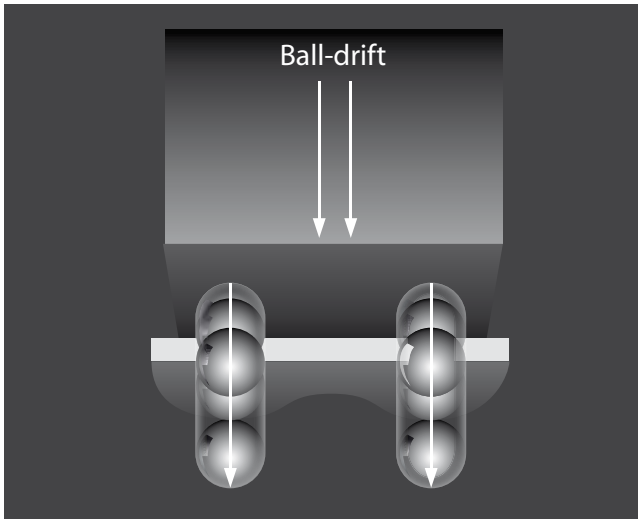

Fig. 6 Ball Drifting

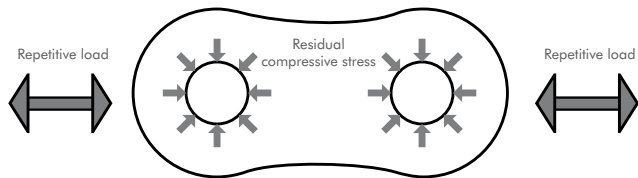

Fig. 7 Residual Compressive Stress

Ball drifting is the process of pressing a hardened steel ball through a hole in an already hardened steel plate (Fig. 6). The goal of this process is to create local plastic deformation and effectively add compressive stress (Fig. 7) to the walls of the hole. Besides this, the process generates precisely controlled holes for an optimum press fit. Together, this leads to significantly improved fatigue life (up to 30%).

8. Shot Peening Process

Shot peening is a process used to produce a compressive residual stress layer and modify mechanical properties of metals. It means impacting a surface with shot (round metallic or ceramic particles) with force sufficient to create plastic deformation.

At TSUBAKI, all basic chain parts (except pins) are shot peened.

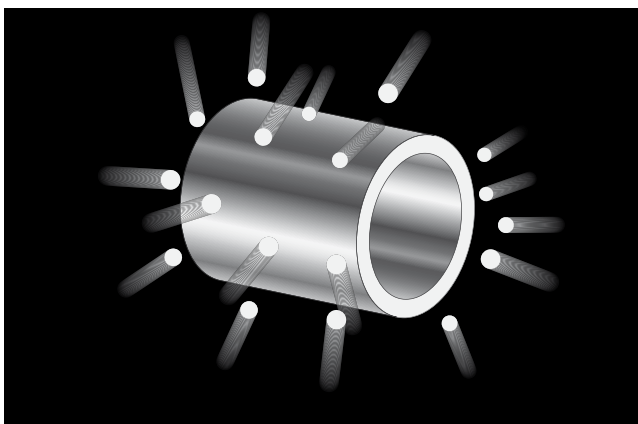

Fig. 8 Shot Peening

Shot Peening increases resistance to:

- fatigue failure
- corrosion fatigue
- hydrogen assisted cracking
- cavitation erosion
- stress corrosion cracking
- galling
- fretting

9. Pre-Loading Process



Fig. 9 Pre-Loading

After the assembly of a chain, TSUBAKI always applies an initial load, which is called a pre-load. The pre-load force approximates the recommended Maximum Allowable Load and is applied to seat the various chain components such as pins, bushes and link plates. The benefit of pre-loading is that it minimizes the initial elongation. Minimization of this initial elongation increases the chains service life therefore pre-loading is very important.

INTRODUCTION TO TSUBAKI ROLLER CHAIN

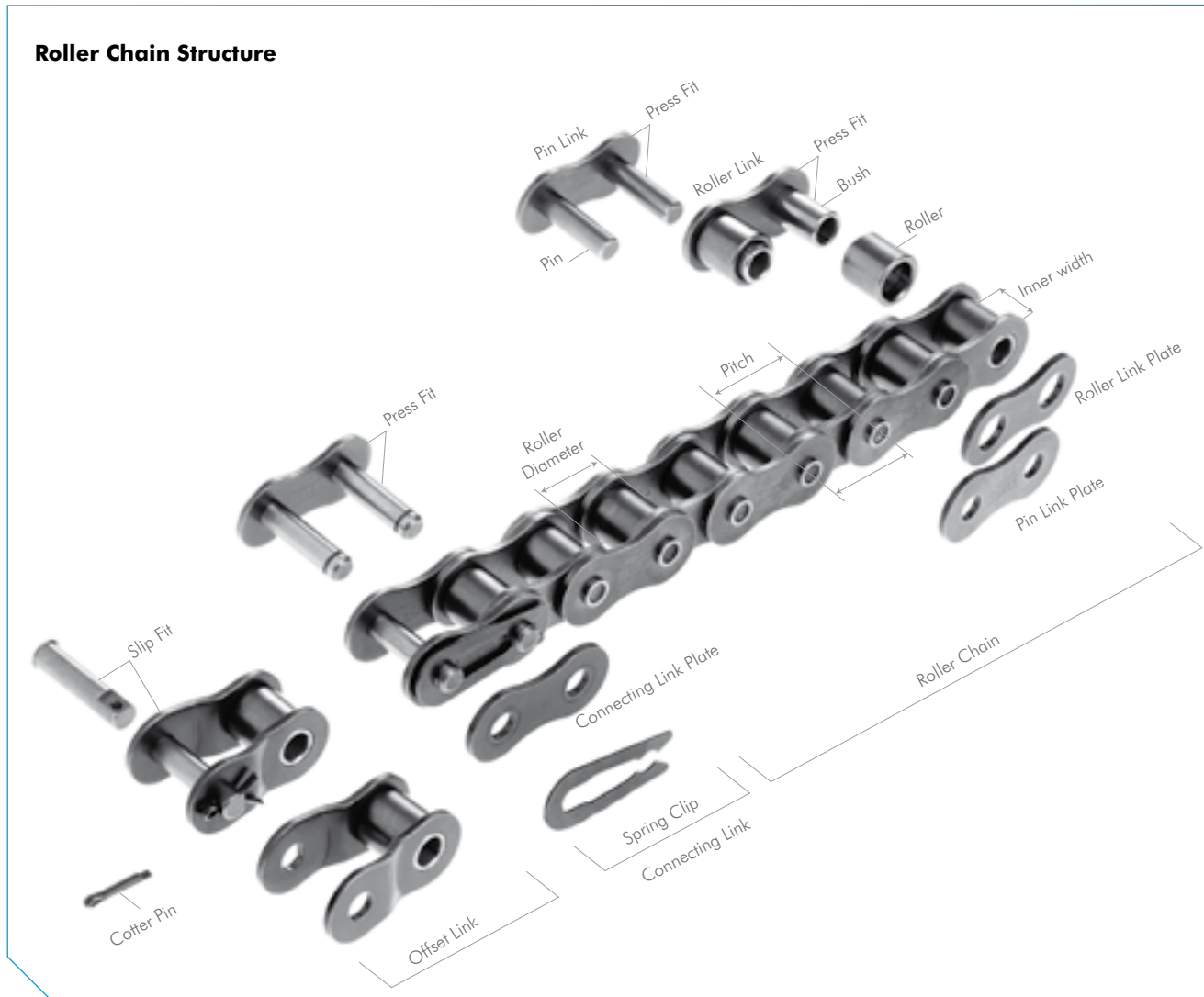

Roller Chain Structure

1. Three Basic Dimensions

Pitch, Roller Diameter and Inner Width are known as the “Three Basic Dimensions of Roller Chain.” When these three dimensions are identical, roller chains and sprockets are dimensionally compatible.

2. Basic Parts Link Plate

The plate is the component that bears the tension placed on the chain. Usually this is a repeated loading, sometimes accompanied by shock. Therefore, the plate must not only have great static tensile strength, it must also hold up to the dynamic forces of load and shock.

Pin

The pin is subject to shearing and bending forces transmitted by the plate. At the same time, it forms a load-bearing part (together with the bush) when the chain flexes during sprocket engagement. Therefore, the pin needs high tensile and shear strength,

resistance to bending, and must also have sufficient endurance against shock and wear.

Bush

The bush is subject to complex forces from all parts, especially from the repetition of shock loads when the chain engages the sprocket. Therefore, the bush needs extremely high shock resistance. In addition, the bush forms a load-bearing part together with the pin and as such requires great wear resistance.

Roller

The roller is subject to impact load as it mates with the sprocket teeth during engagement of the chain with the sprocket. After engagement, the roller changes its point of contact and balance. It is held between the sprocket teeth and bush, and moves on the tooth face while receiving a compression load. Therefore, it must be resistant to wear and still have strength against shock, fatigue and compression. (RS25 and RS35 are bush chains and do not have rollers).

Roller Link

Two bushes are press fit into two roller link plates and rollers are

INTRODUCTION TO TSUBAKI ROLLER CHAIN

Connecting Links

Spring Clip Connecting Link

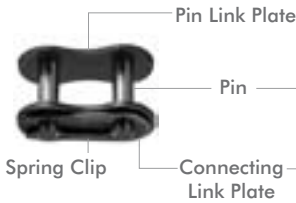

Cotter Pin Connecting Link

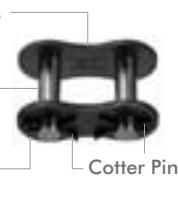

Spring Pin Connecting Link

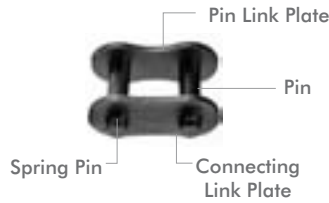

Cotter Pin Connecting Link Multi-Strand (2-strand shown)

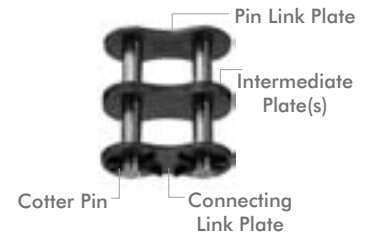

ONE Pitch Offset Links (OL)

Single Strand



Multi-strand (2-strand shown)

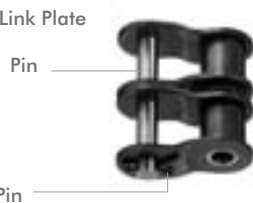

TWO Pitch Offset Links (2POL)

Single Strand



Multi-strand (2-strand shown)



inserted to allow rotation around the outside of the bushes during operation. This is the same for single and for multi strand chains.

Pin Link and Intermediate Plate

The pin link consists of two pins that have been press fit into two pin link plates. In case of multi-strand roller chain up till size 08B, an intermediate plate is added to the pin link. In case of multi-strand roller chain above size 08B, two intermediate plates are added to the pin link. The intermediate plates are slip fit for standard roller chain and press fit for SUPER roller chain.

3. Assembly Parts

Roller chains are usually made up of a number of inner and outer links in an endless formation. Although offset links can be used when there is an odd number of links in the roller chain, it is better to use a design that requires an even number of links. If an odd number of links cannot be avoided, it is recommended to use a two-pitch offset link in stead of a one-pitch offset link. As it is riveted into the chain, a two-pitch offset link has a 100% Maximum Allowable Load, where as the one-pitch offset link has a Maximum Allowable Load of 65%.

Connecting Links

There are three types of connecting links: spring clip connecting link, cotter pin connecting link and spring pin connecting link.

It's common to use slip fit spring clip connecting links for small size roller chains. Cotter pin and spring pin connecting links are used for large size roller chains and on customer request.

Offset Links

An offset link is used when an odd number of chain links is required. Different types are available:

One pitch offset link (OL).

The pin and two plates are slip fit. The fatigue strength is 35% lower than the chain itself.

Two pitch offset link (2POL).

Two pitch offset links are the combination of a roller link and an offset link connected with a rivet pin. The fatigue strength is the same as the fatigue strength of the base chain. Please refer to the dimension tables for roller chain types and sizes suitable for offset links.

BS RUNNER STANDARD ROLLER CHAIN

For standard situations, TSUBAKI can provide you with outstanding roller chain: the BS Runner. The BS Runner is produced according to the appropriate European Standards.

Advantages

TSUBAKI BS Runner is enhanced with the following advantages:

Increased kW Rating

Transmission capacity has been increased by applying the patented TSUBAKI Ring Coining process on the connecting link plate.



Fig. 13 Ring Coined Connecting Link Plate

For easy assembling the pin and link plate of a connecting link are slip fit. In general, this type of connecting link has a 20% lower fatigue strength than the chain itself. However, TSUBAKI developed a special process to eliminate that loss of fatigue strength and still satisfy the customers demand for easy assembly: the patented Ring Coining process. By applying the patented Ring Coining process, TSUBAKI generates a cold deformation around the pin hole of the connecting link plate. This results in residual stress around the pin hole and thereby adds strength. By using this process transmission capacity is 100% of the base chain.

Constant Quality Level

In pursuit of outstanding quality, every TSUBAKI chain is made of a special steel alloy, the specification of which has been developed by the TSUBAKI Engineering Department, for selected steel mills to work with.

Besides that, TSUBAKI produces the BS Runner under highly controlled conditions in its advanced heat treatment facilities. This, in combination with the TSUBAKI fatigue strength confirmation tests, ensures that our customers can always rely on a constant level of TSUBAKI quality.

Customised Pre-Lubrication Service

Proper lubrication is the key to extend the life and improve the performance of a chain. In order to get the best performance in general applications (-10°C to +60°C), all BS Runner drive chains are pre-lubricated.

For special applications, TSUBAKI can provide chains which are pre-lubricated with a special lubricant on customer demand:

- High temperature
- Low temperature
- Food safe
- Outdoor exposure
- Dusty environment

Please consult TSUBAKI for more detailed information.



BS RUNNER STANDARD ROLLER CHAIN

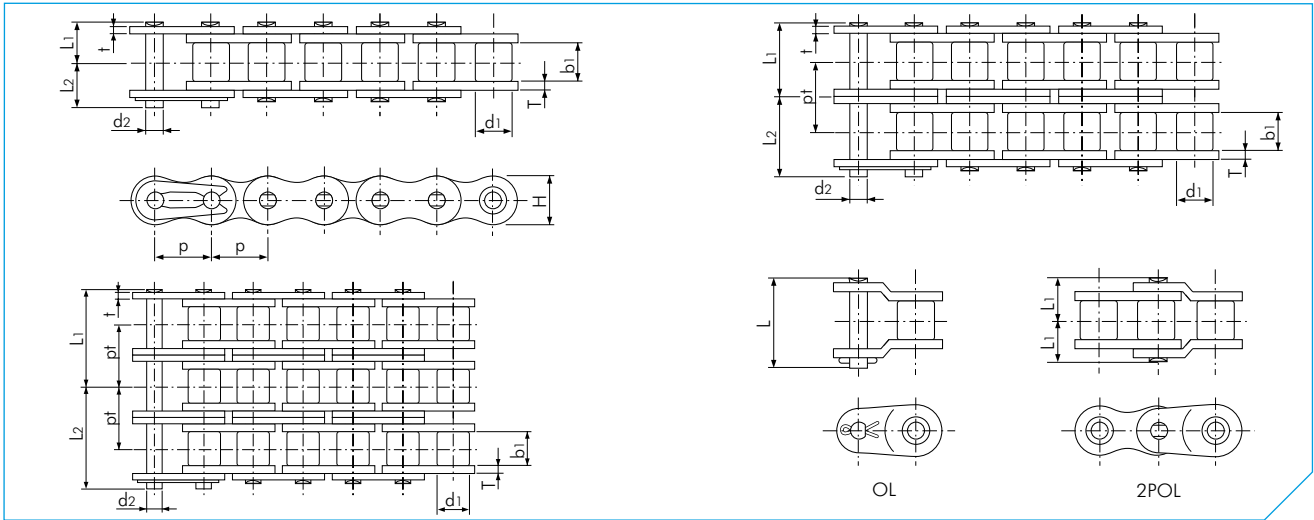

BS Runner

Dimensions in mm

TSUBAKI Chain No.	Pitch p	Roller Diameter d1	Inner Width b1	Pin			Link Plate			Transverse Pitch pt	Min. Tensile Strength acc. to ISO 606 kN	Min. Tensile Strength acc. to Tsubaki kN	Av. Tensile Strength acc. to Tsubaki kN	Approx. Mass kg/m			
				Diameter d2	Length L1	Length L2	Length L	Thickness T	Thickness t						Height H (max)		
RS05B-1	8.00 (0.315")	5.00	3.00	2.30	3.80	4.70	-	0.75	0.75	7.10	-	4.4	5.0	5.8	0.18		
RS05B-2					6.65	7.52	-				5.64	7.8	7.8	8.9	0.35		
RS05B-3					9.45	10.34	-				5.64	11.1	11.2	12.8	0.53		
RF06B-1	9.525 (3/8")	6.35	5.72	3.27	6.10	7.70	14.20	1.30	1.00	8.20	-	8.9	9.0	9.9	0.39		
RF06B-2					11.43	12.57	-				10.24	16.9	17.0	18.7	0.75		
RF06B-3					16.90	17.50	-				10.24	24.9	24.9	27.4	1.11		
RS08B-1	12.70 (1/2")	8.51	7.75	4.45	8.40	10.00	18.40	1.60	1.60	12.00	-	17.8	19.0	20.9	0.70		
RS08B-2					15.30	16.90	33.60				13.92	31.1	32.0	35.2	1.35		
RS08B-3					22.25	23.85	47.60				13.92	44.5	47.5	52.3	2.00		
RS10B-1	15.875 (5/8")	10.16	9.65	5.08	9.55	11.25	21.10	1.50	1.50	14.70	-	22.2	23.0	25.3	0.95		
RS10B-2					17.85	19.55	39.40				16.59	44.5	44.5	49.0	1.85		
RS10B-3					26.15	27.85	56.10				16.59	66.6	66.8	73.5	2.80		
RS12B-1	19.05 (3/4")	12.07	11.68	5.72	11.10	13.00	24.80	1.80	1.80	16.10	-	28.9	31.0	34.1	1.25		
RS12B-2					20.85	22.75	46.30				19.46	57.8	61.0	67.1	2.50		
RS12B-3					30.60	32.50	66.00				19.46	86.7	92.0	101.0	3.80		
RS16B-1	25.40 (1")	15.88	17.02	8.28	17.75	19.95	38.90	4.00	3.20	21.00	-	60.0	70.0	77.0	2.70		
RS16B-2					33.55	35.75	73.80				31.88	106.0	128.0	141.0	5.40		
RS16B-3					49.50	51.70	105.90				31.88	160.0	192.0	211.0	8.00		
RS20B-1	31.75 (1 1/4")	19.05	19.56	10.19	19.90	23.10	46.95	4.40	3.40	26.00	-	95.0	98.1	108.0	3.85		
RS20B-2					38.25	41.45	84.85				36.45	170.0	197.0	217.0	7.65		
RS20B-3					56.50	59.70	121.35				36.45	250.0	295.0	325.0	11.45		
RS24B-1	38.10 (1 1/2")	25.40	25.40	14.63	26.65	31.85	62.00	6.00	5.60	33.40	-	160.0	167.0	184.0	7.45		
RS24B-H-1					29.30	34.20	-				7.50	6.00	36.20	-	234.0	270.0	8.20
RS24B-2					50.80	56.00	112.95				48.36	280.0	335.0	369.0	14.65		
RS24B-3	75.10	80.20	161.35	48.36	425.0	500.0	550.0	21.75									
RS28B-1	44.45 (1 3/4")	27.94	30.99	15.90	32.45	37.45	74.50	7.50	6.30	36.40	-	200.0	200.0	220.0	9.45		
RS28B-2					62.15	67.15	136.85				59.56	360.0	374.0	411.0	18.80		
RS28B-3					91.95	96.95	196.45				59.56	530.0	560.0	616.0	28.20		
RS32B-1	50.80 (2")	29.21	30.99	17.81	32.10	37.70	73.50	7.00	6.30	42.20	-	250.0	255.0	281.0	10.25		
RS32B-2					61.25	66.85	135.25				58.55	450.0	485.0	534.0	21.10		
RS32B-3					90.50	96.10	193.80				58.55	670.0	729.0	802.0	29.90		
RS40B-1	63.50 (2 1/2")	39.37	38.10	22.89	39.25	45.05	88.85	8.50	8.00	52.90	-	355.0	373.0	410.0	16.35		
RS40B-2					75.40	81.20	163.55				72.29	630.0	716.0	788.0	32.00		
RS40B-3					111.50	117.30	235.85				72.29	950.0	1080.0	1190.0	47.75		
RS48B-1	76.20 (3")	48.26	45.72	29.23	49.30	58.80	117.70	12.10	10.00	63.80	-	560.0	565.0	618.0	25.00		
RS48B-2					95.00	104.40	209.00				91.21	1000.0	1000.0	1150.0	50.00		
RS48B-3					140.60	150.00	300.20				91.21	1500.0	1520.0	1750.0	75.00		

Note:

1. Connecting links are clip type for sizes up to RS16B, and cotter type for sizes RS20B to RS48B.
2. RF06B chain has flat-shaped link plates.
3. Intermediate plate of multi strand RF06B-2 and RS08B-2 chain is a solid plate.
4. Center sink riveting is applied to RS08B-1 to RS16B-1 single strand chain.
5. Double stake riveting is applied to all other sizes including multi-strand chain.
6. When a single pitch offset link is used, please calculate a 35% reduction of the fatigue strength.
7. RS24B-H-1 chain is a reinforced RS24B-1 chain.