

SKR



Caged Ball LM Guide Actuator Model SKR

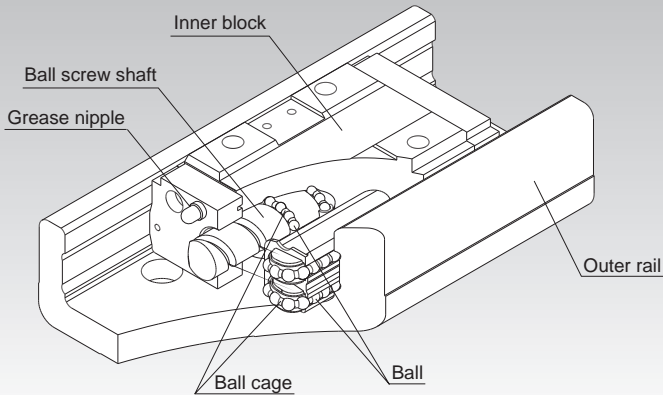

Fig.1 Structure of Caged Ball LM Guide Model SKR

Structure and Features

Caged Ball LM Guide Actuator model SKR is a compact actuator that has a inner block consisting of LM blocks and a ball screw nut integrated inside a U-shaped outer rail.

In addition, this model achieves high speed operation, lower noise and longer-term maintenance-free operation by using ball cages in the LM Guide units and the Ball Screw unit. (A ball cage is used only for the LM guide section of models SKR20 and SKR26 and the ball screws are fitted with QZ lubricators.)

[4-way Equal Load]

Each row of balls is arranged at a contact angle of 45° so that the rated load on the inner block is uniform under loads applied to the inner block in the four directions (radial, reverse radial and lateral directions). As a result, model SKR can be used in any mounting orientation.

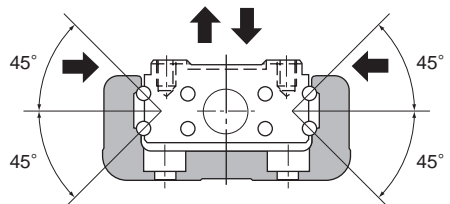

Fig.2 Load Capacity and Contact Angle of Model SKR

[High Rigidity]

Use of an outer rail with a U-shaped cross section increases the rigidity with respect to moment and torsion.

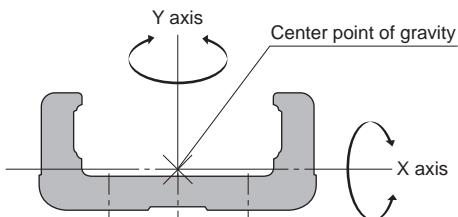

Fig.3 Cross Section of the Outer Rail

Table1 Cross-sectional Characteristics of the Outer rail Rail

Model No.	I_x [mm ⁴]	I_y [mm ⁴]	Mass[kg/m]
SKR20	6.0×10^3	6.14×10^4	2.6
SKR26	1.66×10^4	1.48×10^5	3.9
SKR33	5.35×10^4	3.52×10^6	6.1
SKR46	2.05×10^5	1.45×10^6	12.6
SKR55	2.07×10^5	2.09×10^6	13.2
SKR65	4.51×10^5	5.73×10^6	22.1

I_x =geometrical moment of inertia around X axis

I_y =geometrical moment of inertia around Y axis

[High Accuracy]

Since the linear guide section consists of 4 rows of circular-arc grooves that enable balls to smoothly move even under a preload, a highly rigid guide with no clearance is achieved. Additionally, variation in frictional resistance caused by load fluctuation is minimized, allowing the system to follow highly accurate feed.

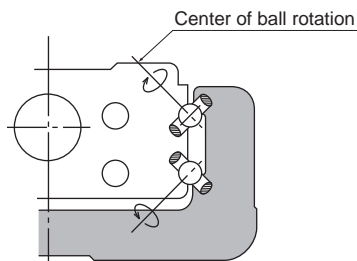

Fig.4 Contact Structure of SKR

[Space Saving]

Due to an integral structure where LM Guide units are placed on both side faces of the inner block and a Ball Screw unit is placed in the center of the inner block, a highly rigid and highly accurate actuator with a minimal space is achieved.

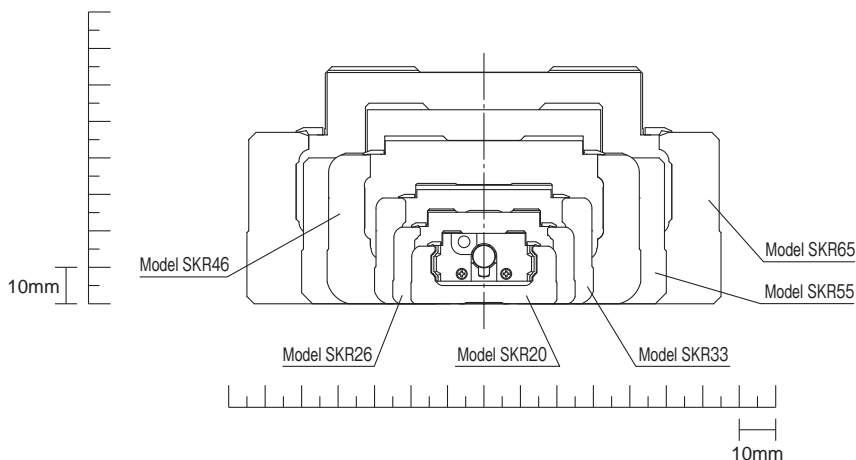

Fig.5 Cross Sectional Drawing

Caged Ball Technology

[High Speed]

Model SKR supports a latest high-rotation servomotor ($6,000 \text{ min}^{-1}$) by using a ball cage and is capable of operating at higher speed than the full-ball type model KR.

Models SKR33/55/65 are available in more leads variations to achieve higher speed operation and high leads are available which was not feasible with the model KR.

Model No.	Lead	
	SKR	KR
33	6, 10, 20	6, 10
55	20, 30, 40	20
65	20, 25, 30, 50	25

[High Lubricity]

Model SKR uses ball cages to eliminate friction between balls and significantly improve torque characteristics. As a result, the torque fluctuation is reduced and superb lubricity is achieved.

Item	Description
Shaft diameter/lead	$\phi 13/10\text{mm}$
Shaft rotation speed	60min^{-1}

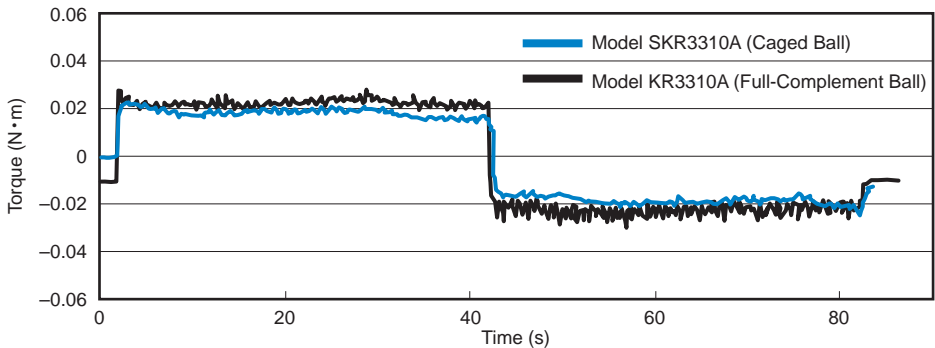

Fig.6 Comparison of Torque Fluctuation between Model SKR and Model KR

[Low Noise, Acceptable Running Sound]

In model SKR, the use of a ball cage in the LM Guide section and Ball Screw section (excluding models SKR20/26) has eliminated collision noise between the balls. As a result, low noise and acceptable running sound are achieved.

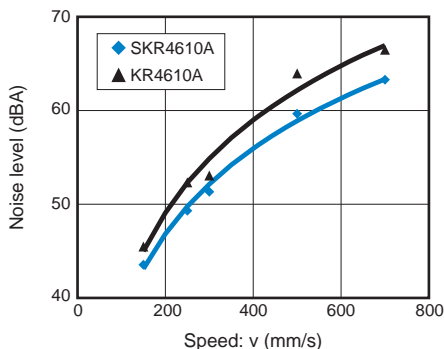

Fig.7 Comparison of Noise between Model SKR4610A and Model KR4610A

[Long-term Maintenance-free Operation]

With model SKR, the ball cage effect helps increase grease retention and achieve long-term maintenance-free operation.

[Long service life—3 times]

With model SKR, both the LM Guide unit and the Ball Screw unit have larger basic dynamic load ratings than the full-ball type model KR, and therefore a longer service lives are achieved.

The rated service life is calculated from the following equation.

LM guide unit

$$L = (C/P)^3 \times 50$$

L : Nominal life (km)

C : Basic dynamic load rating (N)

P : Applied load (N)

Ball screw unit

$$L = (Ca/Fa)^3 \times 10^6$$

L : Nominal life (rev)

Ca : Basic dynamic load rating (N)

Fa : Applied axial load (N)

As indicated in the equation above, the greater the basic dynamic load rating, the longer the service life of both the LM Guide unit and the Ball Screw unit.

Table2 Comparison of Basic Dynamic Load Rating between Model SKR and Model KR

Unit: N

Basic dynamic load rating		SKR 20	KR 20	SKR 26	KR 26	SKR 33	KR 33	SKR 46	KR 46	SKR 55	KR 55	SKR 65	KR 65
LM guide unit C	Long type block	6010	3590	13000	7240	17000	11600	39500	27400	55400	38100	74400	50900
	Short type block	—	—	—	—	11300	4900	28400	14000	—	—	—	—
Ball screw unit Ca		660	660	2350	2350	2700	1760	4240	3040	10900	3620	12000	5680

Note) On the SKR20/26, only the LM guide section features a ball cage.

[Seal]

Model SKR is equipped with end seals and side seals for dust prevention as standard.

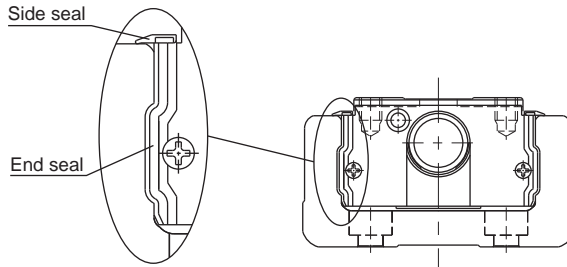

Table3 shows the rolling resistance and seal resistance per inner block (guide section).

Table3 Maximum Resistance Value Unit: N

Model No.	Rolling resistance value	Seal resistance value	Total
SKR20	4.0	0.8	4.8
SKR26	4.5	1.2	5.7
SKR33	3.0	1.7	4.7
SKR46	6.0	2.1	8.1
SKR55	14.0	3.8	17.8
SKR65	20.0	4.1	24.1

Types and Features

Model SKR-A (with a Single Long Type Block)

Representative model of SKR.

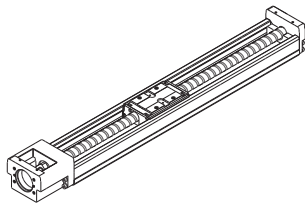

Model SKR-A

Model SKR-B (with Two Long Type Blocks)

Equipped with two units of the inner block of model SKR-A, this model achieves higher rigidity and higher load carrying capacity.

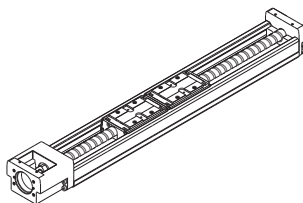

Model SKR-B

Model SKR-C (with a Single Short Type Block)

This model has a shorter overall length of the inner block and a longer stroke than model SKR-A.

* With model SKR3320, a short-block type is not available.

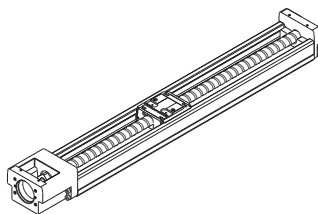

Model SKR-C

Model SKR-D (with Two Short Type Blocks)

Equipped with two units of the inner block of model SKR-C, this design allows a span between blocks that suits the equipment, thus to achieve high rigidity.

* With model SKR3320, a short-block type is not available.

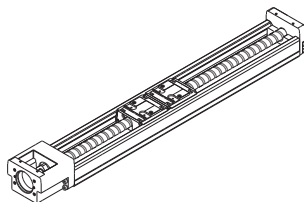

Model SKR-D

Load Ratings in All Directions and Static Permissible Moment

[Load Rating]

Caged Ball LM Guide Actuator Model SKR consists of an LM Guide, a Ball Screw and a support bearing.

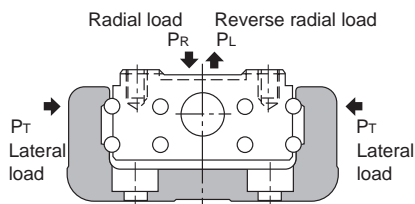

● LM Guide Unit

Model SKR is capable of receiving loads in four directions (radial, reverse radial and lateral directions). Its basic load ratings are equal in all four directions (radial, reverse radial and lateral directions), and their values are indicated in Table4.

● Ball Screw Unit

Since the inner block is incorporated with a ball screw nut, model SKR is capable of receiving an axial load. The basic load rating value is indicated in Table4.

● Bearing Unit (Fixed Side)

Since housing A contains an angular bearing, model SKR is capable of receiving an axial load. The basic load rating value is indicated in Table4.

[Equivalent Load (LM Guide Unit)]

The equivalent load when the LM Guide unit of model SKR simultaneously receives loads in all directions is obtained from the following equation.

$$P_E = P_R (P_L) + P_T$$

P_E : Equivalent load (N)

: Radial direction

: Reverse radial direction

: Lateral directions

P_R : Radial load (N)

P_L : Reverse radial load (N)

P_T : Lateral load (N)

Table4 Load Rating of Model SKR

Model No.			SKR20		SKR26		SKR33*		
			SKR2001	SKR2006	SKR2602	SKR2606	SKR3306	SKR3310	SKR3320
LM guide unit	Basic dynamic load rating C (N)	Long type block	6010		13000		17000		
		Short type block	—		—		11300	—	
	Basic static load rating C ₀ (N)	Long type block	8030		16500		20400		
		Short type block	—		—		11500	—	
	Radial clearance (mm)	Normal grade, high accuracy grade	-0.004 to 0		-0.006 to 0		-0.004 to 0		
		Precision grade	-0.006 to -0.004		-0.007 to -0.006		-0.012 to -0.004		
Ball screw unit	Basic dynamic load rating C _a (N)	Normal grade, high accuracy grade	660	860	2350	1950	4400	2700	2620
		Precision grade	660	1060	2350	2390			
	Basic static load rating C _{0a} (N)	Normal grade, high accuracy grade	1170	1450	4020	3510	6290	3780	3770
		Precision grade	1170	1600	4020	3900			
	Screw shaft diameter (mm)		6		8		13		
	Ball Screw lead (mm)		1	6	2	6	6	10	20
	Thread minor diameter (mm)		5.3	5.0	6.6	6.7	10.8		
	Ball center-to-center diameter (mm)		6.15	6.3	8.3	8.4	13.5		
Bearing unit (Fixed side)	Axial direction	Basic dynamic load rating C _a (N)	1150		2000		6250		
		Static permissible load P _{0a} (N)	735		1230		2700		

*For use in a special environment or where an axial load (25% or more of the basic dynamic load rating C_a) is applied, a special type is also available. Contact THK for details.

Note1) The load ratings in the LM Guide unit each indicate the load rating per inner block.

Note2) With model SKR3320, a short-block type is not available.

SKR46*		SKR55			SKR65			
SKR4610	SKR4620	SKR5520	SKR5530	SKR5540	SKR6520	SKR6525	SKR6530	SKR6550
39500		55400			74400			
28400		—			—			
45900		62500			81600			
28700		—			—			
-0.006 to 0		-0.007 to 0			-0.008 to 0			
-0.016 to -0.006		-0.019 to -0.007			-0.022 to -0.008			
4350	4240	10900	7000	6800	12100	12000	8200	7600
6990	7040	17600	11500	9900	21600	22000	14500	12600
15		20			25			
10	20	20	30	40	20	25	30	50
12.5		17.1			22.1			
15.75		20.75			25.75			
6700		7600			13700			
3330		3990			5830			

[Permissible Moment (LM Guide Unit)]

The Inner block is capable of receiving moment loads in all three (3) directions.

A2-15 Table 5 shows the permissible static moment in the M_A , M_B and M_C directions.

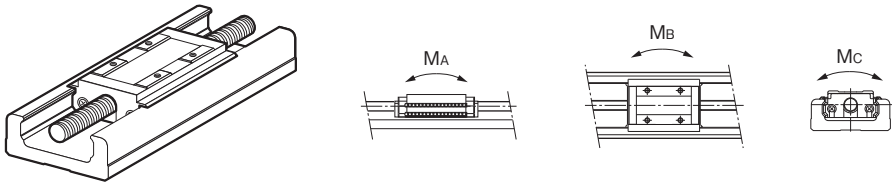

With a single long type block (Model SKR-A)

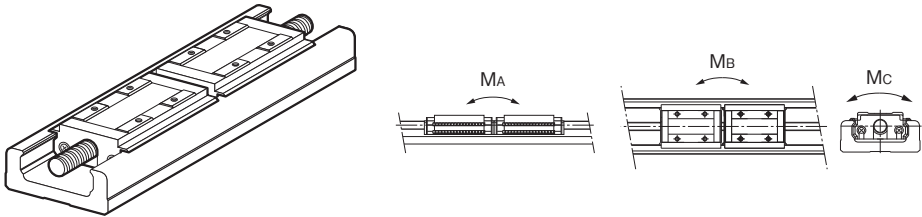

With double long type blocks (Model SKR-B)

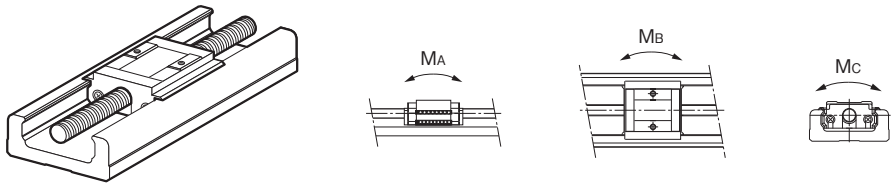

With a single short type block (Model SKR-C)

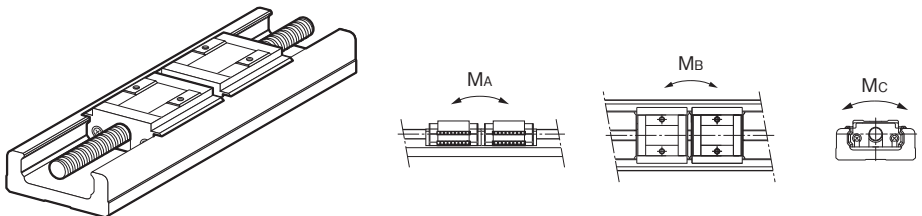

With double short type blocks (Model SKR-D)

Table5 Static Permissible Moments of Model SKR

Unit: N·m

Model No.	Static permissible moment		
	M_a	M_b	M_c
SKR20-A	38	38	98
SKR20-B	207	207	197
SKR26-A	117	117	265
SKR26-B	589	589	530
SKR33-A	173	173	424
SKR33-B	990	990	848
SKR33-C	58	58	240
SKR33-D	390	390	480
SKR46-A	579	579	1390
SKR46-B	3240	3240	2780
SKR46-C	236	236	870
SKR46-D	1460	1460	1740
SKR55-A	923	923	2276
SKR55-B	5125	5125	4552
SKR65-A	1366	1366	3868
SKR65-B	7702	7702	7736

Note1) Symbols A, B, C or D in the end of each model number indicates the inner block size and the number of inner blocks used.

A: With a single long type block

B: With double long type blocks

C: With a single short type block

D: With double short type blocks

Note2) The values for models SKR-B/D indicate the values when double inner blocks are used in close contact with each other.

Note3) Static permissible moment is the maximum moment that can be permitted while the product is stationary.

Maximum Speeds with Different Strokes

Table6 Maximum speed

Model No.	Ball Screw lead (mm)	Stroke (mm)		Outer rail length (mm)	Maximum speed (mm/s)		
		Long type block	Short type block		Long type block	Short type block	
SKR20	1	30	—	100	100	—	
		80	—	150	100	—	
		130	—	200	100	—	
	6	30	—	100	600	—	
		80	—	150	600	—	
		130	—	200	600	—	
SKR26	2	60	—	150	200	—	
		110	—	200	200	—	
		160	—	250	200	—	
		210	—	300	200	—	
	6	60	—	150	600	—	
		110	—	200	600	—	
		160	—	250	600	—	
		210	—	300	600	—	
		—	—	—	—	—	
SKR33	6	45	70	150	600	—	
		95	120	200	600	—	
		195	220	300	600	—	
		295	320	400	600	—	
		395	420	500	600	—	
		495	520	600	550	500	
		595	620	700	390	360	
	10	45	70	150	1000	—	
		95	120	200	1000	—	
		195	220	300	1000	—	
		295	320	400	1000	—	
		395	420	500	1000	—	
		495	520	600	920	830	
		595	620	700	650	600	
	20	45	—	150	2000	—	
		95	—	200	2000	—	
		195	—	300	2000	—	
		295	—	400	2000	—	
		395	—	500	2000	—	
		495	—	600	1780	—	
		595	—	700	1270	—	
	SKR46	10	190	220	340	1000	—
			290	320	440	1000	—
			390	420	540	1000	—
			490	520	640	1000	910
			590	620	740	730	660
			690	720	840	550	500
790			820	940	430	400	
20		190	220	340	2000	—	
		290	320	440	2000	—	
		390	420	540	2000	—	
		490	520	640	1980	1770	
		590	620	740	1430	1300	
		690	720	840	1080	990	
		790	820	940	840	780	
		—	—	—	—	—	

*Indicates a stroke when one inner block is incorporated.

Note1) The maximum speed is the value restricted by the permissible rotation speed of the Ball Screw or the permissible speed of the guide, with the motor rotating at 6,000 min⁻¹.

Note2) When considering the use of this model at speed higher than the maximum speed indicated above, contact THK.

Model No.	Ball Screw lead (mm)	Stroke* (mm)		Outer rail length (mm)	Maximum speed (mm/s)	
		Long type block	Short type block		Long type block	Short type block
SKR55	20	800	—	980	1100	—
		900		1080	880	
		1000		1180	730	
		1100		1280	610	
		1200		1380	520	
	30	800		980	1650	
		900		1080	1330	
		1000		1180	1100	
		1100		1280	920	
		1200		1380	780	
	40	800		980	2160	
		900		1080	1750	
		1000		1180	1440	
		1100		1280	1210	
		1200		1380	1030	
	SKR65	20		790	980	
990			1180	970		
1190			1380	690		
1490			1680	450		
25		790	980	1810		
		990	1180	1200		
		1190	1380	850		
		1490	1680	550		
30		790	980	2210		
		990	1180	1460		
		1190	1380	1030		
		1490	1680	670		
50		790	980	3000		
		990	1180	2350		
		1190	1380	1680		
		1490	1680	1100		

*Indicates a stroke when one inner block is incorporated.

Note1) The maximum speed is restricted by the permissible rotation speed of the ball screw, the permissible speed of the guide or 6,000 min⁻¹ of motor speed.

Note2) When considering the use of this model at speed higher than the maximum speed indicated above, contact THK.

Lubrication

Table7 shows standard greases used in model SKR and grease nipple types.

Table7 Types of standard grease and grease nipples used

Model No.	Standard grease	Grease nipple used
SKR20	THK AFA Grease	PB107
SKR26	THK AFA Grease	PB107
SKR33	THK AFB-LF Grease	PB107
SKR46	THK AFB-LF Grease	A-M6F
SKR55	THK AFB-LF Grease	A-M6F
SKR65	THK AFB-LF Grease	A-M6F

Static Safety Factor

Caged Ball LM Guide Actuator Model SKR consists of an LM Guide, a Ball Screw and a support bearing. The static safety factor and the service life of each component can be obtained from the basic load rating indicated in "Rated load of model SKR" (see Table 4-12).

[Calculating the Static Safety Factor]

● LM Guide Unit

To calculate a load applied to the LM Guide of model SKR, the average load required for calculating the service life and the maximum load needed for calculating the static safety factor must be obtained first. In particular, if the system starts and stops frequently, or if a large moment caused by an overhung load is applied to the system, it may receive an unexpectedly large load.

When selecting a model number, make sure that the desired model is capable of receiving the required maximum load (whether stationary or in motion).

$$f_s = \frac{C_0}{P_{\max}}$$

f_s : Static safety factor

C_0 : Basic static load rating (N)

P_{\max} : Maximum applied load (N)

*The basic static load rating is a static load with a constant direction and magnitude whereby the sum of the permanent deformation of the rolling element and that of the raceway on the contact area under the maximum stress is 0.0001 times the rolling element diameter.

● Ball Screw Unit/Bearing Unit(Fixed Side)

If an unexpected external force is applied in the axial direction as a result of an inertia caused by an impact or start and stop while model SKR is stationary or operating, it is necessary to take into account the static safety factor.

$$f_s = \frac{C_{0a}}{F_{\max}}$$

f_s : Static safety factor

C_{0a} : Basic static load rating (N)

F_{\max} : Maximum applied load (N)

[Standard Values for the Static Safety Factor (f_s)]

Machine type	Load conditions	Minimum Static Safety Factor (f_s)
General industrial machinery	Without vibration or impact	1.0 to 3.5
	With vibration or impact	2.0 to 5.0

*The standard value of the static safety factor may vary depending on the load conditions as well as environment, lubrication status, mounting accuracy, and/or rigidity.

Service Life

[LM Guide Unit]

● Nominal Life

The nominal life (L) means the total travel distance that 90% of a group of units of the same LM Guide model can achieve without flaking (scale-like pieces on the metal surface) after individually running under the same conditions.

The nominal life of the LM Guide is obtained using the following equation.

$$L = \left(\frac{f_c \cdot C}{f_w \cdot P_c} \right)^3 \times 50$$

L : Nominal life (km) f_w : Load factor (see Table8 on **A2-21**)
 C : Basic dynamic load rating (N) f_c : Contact factor (see Table9 on **A2-22**)
 P_c : Calculated applied load (N)

- If a moment is applied, calculate the equivalent load by multiplying the applied moment by the equivalent factor indicated in Table10 on **A2-22**.

$$P_m = K \cdot M$$

P_m : Equivalent load (per inner block) (N)
 K : Equivalent moment factor
 M : Applied moment (N-mm)

(If planning to use the product with a wide inner block span, contact THK.)

If moment M_c is applied to model SKR-B/D

$$P_m = \frac{K_c \cdot M_c}{2}$$

- If a radial load (P) and a moment are simultaneously applied to model SKR

$$P_E = P_m + P$$

P_E : Overall equivalent radial load (N)

Perform a nominal life calculation using the above data.

● Service Life Time

When the nominal life (L) has been obtained, the service life time is obtained using the following equation (if the stroke length and the number of reciprocations per minute are constant).

$$L_h = \frac{L \times 10^6}{2 \cdot \ell_s \cdot n_1 \times 60}$$

L_h : Service life time (h) n_1 : Number of reciprocations per minute (min^{-1})
 ℓ_s : Stroke length (mm)

[Ball Screw Unit/Bearing Unit(Fixed Side)]

● Nominal Life

The nominal life (L) means the total travel distance that 90% of a group of units of the same Ball Screw (bearing) can achieve without flaking after individually running under the same conditions.

The nominal life of the Ball Screw unit/bearing unit (fixed side) is obtained using the following equation.

Table8 Load Factor (f_w)

$$L = \left(\frac{C_a}{f_w \cdot F_a} \right)^3 \times 10^6$$

- L : Nominal life (rev)
 C_a : Basic dynamic load rating (N)
 F_a : Axial load (N)
 f_w : Load factor (see Table8)

Vibrations/impact	Speed(V)	f_w
Faint	Very low $V \leq 0.25\text{m/s}$	1 to 1.2
Weak	Slow $0.25\text{m/s} < V \leq 1\text{m/s}$	1.2 to 1.5
Medium	Medium $1\text{m/s} < V \leq 2\text{m/s}$	1.5 to 2
Strong	High $V > 2\text{m/s}$	2 to 3.5

● Service Life Time

When the nominal life (L) has been obtained, the service life time is obtained using the following equation (if the stroke length and the number of reciprocations per minute are constant).

$$L_h = \frac{L \cdot \ell}{2 \cdot \ell_s \cdot n_1 \times 60}$$

L_h : Service life time

(h)

n_1 : Number of reciprocations per minute (min^{-1})

ℓ_s : Stroke length

(mm)

ℓ : Ball Screw lead

(mm)

■ f_c : Contact Factor

If two inner blocks are used in close contact with each other with model SKR-B/D, multiply the basic load rating by the corresponding contact factor indicated in Table9.

Table9 Contact Factor (f_c)

Block type	Contact factor f_c
Model SKR-B Model SKR-D	0.81

■ f_w : Load Factor

In general, machines in reciprocal motion are likely to cause vibration and impact during operation, and it is particularly difficult to accurately determine each of vibration generated during high-speed operation, impact applied during repeated starting and stopping in normal use, etc. Therefore, where the effect of speed vibration is estimated to be significant, divide the basic load rating (C) by an empirically obtained load factor.

■ K : Moment Equivalent Factor (LM Guide Unit)

When model SKR travels under a moment, the distribution of load applied to the LM Guide is locally large. In such cases, calculate the load by multiplying the moment value by the corresponding moment equivalent factor indicated in Table10.

Symbols K_A , K_B and K_C indicate the moment equivalent loads in the M_A , M_B and M_C directions, respectively.

Table10 Equivalent moment factor(K)

Model No.	K_A	K_B	K_C
SKR20-A	2.34×10^{-1}	2.34×10^{-1}	8.07×10^{-2}
SKR20-B	4.38×10^{-2}	4.38×10^{-2}	8.07×10^{-2}
SKR26-A	1.59×10^{-1}	1.59×10^{-1}	6.17×10^{-2}
SKR26-B	3.18×10^{-2}	3.18×10^{-2}	6.17×10^{-2}
SKR33-A	1.42×10^{-1}	1.42×10^{-1}	5.05×10^{-2}
SKR33-B	2.47×10^{-2}	2.47×10^{-2}	5.05×10^{-2}
SKR33-C	2.39×10^{-1}	2.39×10^{-1}	5.05×10^{-2}
SKR33-D	3.54×10^{-2}	3.54×10^{-2}	5.05×10^{-2}
SKR46-A	9.51×10^{-2}	9.51×10^{-2}	3.46×10^{-2}
SKR46-B	1.70×10^{-2}	1.70×10^{-2}	3.46×10^{-2}
SKR46-C	1.46×10^{-1}	1.46×10^{-1}	3.46×10^{-2}
SKR46-D	2.36×10^{-2}	2.36×10^{-2}	3.46×10^{-2}
SKR55-A	8.12×10^{-2}	8.12×10^{-2}	2.88×10^{-2}
SKR55-B	1.46×10^{-2}	1.46×10^{-2}	2.88×10^{-2}
SKR65-A	7.16×10^{-2}	7.16×10^{-2}	2.21×10^{-2}
SKR65-B	1.27×10^{-2}	1.27×10^{-2}	2.21×10^{-2}

K_A : Moment equivalent factor in the M_A direction.

K_B : Moment equivalent factor in the M_B direction.

K_C : Moment equivalent factor in the M_C direction.

(Note) The values for models SKR-B/D indicate the values when double inner blocks are used in close contact with each other.

Accuracy Standards

The accuracy standard of model SKR is defined in positioning repeatability, positioning accuracy, running parallelism (vertical direction) and backlash.

[Positioning Repeatability]

After repeating positioning to a given point in the same direction seven times, measure the halting point and obtain the value of half the maximum difference. Perform this measurement in the center and both ends of the travel distance; use the maximum difference as the measurement value and express the value of half the maximum difference with a “±” sign prefixed to the value.

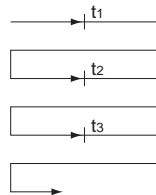

Fig.8 Positioning Repeatability

[Positioning Accuracy]

Using the maximum stroke as the reference length, express the maximum error between the actual distance traveled from the reference point and the command value in an absolute value as positioning accuracy.

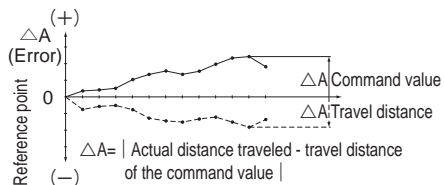

Fig.9 Positioning Accuracy

[Running of Parallelism (Vertical direction)]

Place a straightedge on the surface table where model SKR is mounted, measure almost throughout the travel distance of the inner block using a test indicator. Use the maximum difference among the readings within the travel distance as the running parallelism measurement.

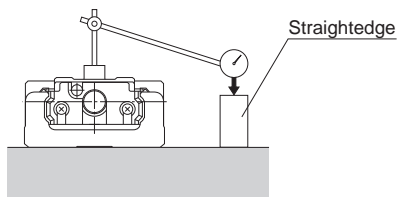

Fig.10 Running of Parallelism

[Backlash]

Feed and slightly move the inner block and read the measurement on the test indicator as the reference value. Subsequently, apply a load to the inner block from the same direction (table feed direction), and then release the inner block from the load. Use the difference between the reference value and the return as the backlash measurement.

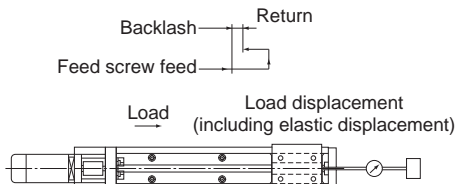

Fig.11 Backlash

Perform this measurement in the center and near both ends, and use the maximum value as the measurement value.

The accuracies of model SKR are classified into normal grade (no symbol), high accuracy grade (H) and precision grade (P). Tables below show standards for all the accuracies.

Table11 Normal Grade (No Symbol)

Unit: mm

Model No.	Stroke	Outer rail length	Positioning Repeatability	Positioning Accuracy	Running Parallelism (Vertical Direction)	Backlash	Starting torque (N-cm)
SKR20	30	100	±0.01	No standard defined	No standard defined	0.02	0.5
	80	150					
	130	200					
SKR26	60	150	±0.01	No standard defined	No standard defined	0.02	1.5
	110	200					
	160	250					
	210	300					
SKR33	45	150	±0.01	No standard defined	No standard defined	0.02	7
	95	200					
	195	300					
	295	400					
	395	500					
	495	600					
SKR46	595	700	±0.01	No standard defined	No standard defined	0.02	10
	190	340					
	290	440					
	390	540					
	490	640					
	590	740					
	690	840					
SKR55	790	940	±0.01	No standard defined	No standard defined	0.05	12
	800	980					
	900	1080					
	1000	1180					
	1100	1280					
SKR65	1200	1380	±0.01	No standard defined	No standard defined	0.05	12
	790	980					
	990	1180					
	1190	1380					
	1490	1680	±0.012				15

*Indicates stroke length when one long-type inner block is incorporated.

Note1) The evaluation method for accuracy standards complies with THK standards.

Note2) The starting torque represents the value when the following grease is used.

Models SKR20 and SKR26 : THK AFA Grease

Models SKR33, SKR46, SKR55 and SKR65 : THK AFB-LF Grease

Note3) If highly viscous grease such as vacuum grease and clean room grease is used, the actual starting torque may exceed the corresponding value in the table. Use much care in selecting a motor.

Note4) Contact THK for accuracy information of units longer than the standard length.

Table12 High Accuracy Grade (H)

Unit: mm

Model No.	Stroke*	Outer rail length	Positioning Repeatability	Positioning Accuracy	Running of Parallelism (Vertical direction)	Backlash	Starting torque (N-cm)
SKR20	30	100	±0.005	0.06	0.025	0.01	0.5
	80	150					
	130	200					
SKR26	60	150	±0.005	0.06	0.025	0.01	1.5
	110	200					
	160	250					
	210	300					
SKR33	45	150	±0.005	0.06	0.025	0.02	7
	95	200					
	195	300					
	295	400		0.10	0.035		
	395	500					
	495	600					
	595	700					
SKR46	190	340	±0.005	0.10	0.035	0.02	10
	290	440					
	390	540					
	490	640		0.12	0.04		
	590	740					
	690	840					
	790	940					
SKR55	800	980	±0.005	0.18	0.05	0.05	12
	900	1080		0.25			
	1000	1180					
	1100	1280					
	1200	1380					
SKR65	790	980	±0.008	0.18	0.05	0.05	12
	990	1180		0.2			
	1190	1380					
	1490	1680		0.28			0.055

*Indicates stroke length when one long-type inner block is incorporated.

Table13 Precision Grade (P)

Unit: mm

Model No.	Stroke*	Outer rail length	Positioning Repeatability	Positioning Accuracy	Running of Parallelism (Vertical direction)	Backlash	Starting torque (N-cm)
SKR20	30	100	±0.003	0.02	0.01	0.003	1.2
	80	150					
	130	200					
SKR26	60	150	±0.003	0.02	0.01	0.003	4
	110	200					
	160	250					
	210	300					
SKR33	45	150	±0.003	0.02	0.01	0.003	15
	95	200					
	195	300					
	295	400		0.025	0.015		
	395	500					
	495	600					
SKR46	595	700	±0.003	0.03	0.02	0.003	15
	190	340		0.025	0.015		
	290	440					
	390	540					
	490	640					
590	740	0.03	0.02	17			
SKR55	800	980	±0.005	0.035	0.025	0.003	17
	900	1080					
	1000	1180		0.04	0.03		
SKR65	790	980	±0.005	0.035	0.025	0.005	20
	990	1180					
	1190	1380		0.04	0.03		

*Indicates stroke length when one long-type inner block is incorporated.

Note1) The evaluation method complies with THK standards.

Note2) The starting torque represents the value when the following grease is used.

Models SKR20 and SKR26 : THK AFA Grease

Models SKR33, SKR46, SKR55 and SKR65 : THK AFB-LF Grease

Note3) If harder grease is used, such as vacuum/clean-room grease, the actual starting torque may exceed the values listed.

Note4) Contact THK for information on accuracy for lengths equal to or longer than the standard outer rail.

Model Number Coding

Model No.	Ball Screw Lead	Inner block type	Stroke	Accuracy
SKR33	10	A	0195	P
①	②	③	④	⑤

SKR20	01 : 1mm	A	0025 : 25mm	No symbol: normal grade H : High accuracy grade P : Precision Grade
SKR26	02 : 2mm	B	0050 : 50mm	
SKR33	06 : 6mm	C	∩	
SKR46	10 : 10mm	D	1490 : 1490mm	
SKR55	20 : 20mm			
SKR65	25 : 25mm			
	30 : 30mm			
	40 : 40mm			
	50 : 50mm			

If "2" (with Bellows) was selected for the cover ⑦, specify a stroke incorporating the bellows (→ **A2-47**).

The available ball screw leads differ depending on the model.

SKR20 : "01", "06"

SKR26 : "02", "06"

SKR33 : "06", "10", "20" (20 mm is available for inner block type A and B only)

SKR46 : "10", "20"

SKR55 : "20", "30", "40"

SKR65 : "20", "25", "30", "50"

With/without a motor	Cover	Sensor	Housing A/ Intermediate Flange																																			
0	1	B	AQ																																			
⑥	⑦	⑧	⑨																																			
<table border="1"> <tr><td>0: direct-coupled (without a motor)</td></tr> <tr><td>1: direct-coupled (with a motor, specified by the customer)</td></tr> </table>	0: direct-coupled (without a motor)	1: direct-coupled (with a motor, specified by the customer)	<table border="1"> <tr><td>0: without a cover</td></tr> <tr><td>1: with a cover</td></tr> <tr><td>2: with a bellows</td></tr> </table>	0: without a cover	1: with a cover	2: with a bellows	<table border="1"> <tr><td>0: none</td></tr> <tr><td>1</td></tr> <tr><td>2</td></tr> <tr><td>6</td></tr> <tr><td>7</td></tr> <tr><td>B</td></tr> <tr><td>E</td></tr> <tr><td>H</td></tr> <tr><td>L</td></tr> <tr><td>J</td></tr> <tr><td>M</td></tr> </table>	0: none	1	2	6	7	B	E	H	L	J	M	<table border="1"> <tr><td>10</td></tr> <tr><td>20</td></tr> <tr><td>30</td></tr> <tr><td>40</td></tr> <tr><td>60</td></tr> <tr><td>A0</td></tr> <tr><td>A5</td></tr> <tr><td>A6</td></tr> <tr><td>AM</td></tr> <tr><td>AN</td></tr> <tr><td>AP</td></tr> <tr><td>AQ</td></tr> <tr><td>AR</td></tr> <tr><td>AS</td></tr> <tr><td>AT</td></tr> <tr><td>AU</td></tr> <tr><td>AV</td></tr> <tr><td>AY</td></tr> <tr><td>AZ</td></tr> </table>	10	20	30	40	60	A0	A5	A6	AM	AN	AP	AQ	AR	AS	AT	AU	AV	AY	AZ
0: direct-coupled (without a motor)																																						
1: direct-coupled (with a motor, specified by the customer)																																						
0: without a cover																																						
1: with a cover																																						
2: with a bellows																																						
0: none																																						
1																																						
2																																						
6																																						
7																																						
B																																						
E																																						
H																																						
L																																						
J																																						
M																																						
10																																						
20																																						
30																																						
40																																						
60																																						
A0																																						
A5																																						
A6																																						
AM																																						
AN																																						
AP																																						
AQ																																						
AR																																						
AS																																						
AT																																						
AU																																						
AV																																						
AY																																						
AZ																																						
<p>If "0" is selected, a coupling is not attached. If a coupling is required, please indicate so.</p> <p>"1" means that a motor specified by the customer is mounted.</p> <p>For item ⑨, select a housing A/intermediate flange that matches the specified motor.</p>																																						
<p>Several motors by different manufacturers can be mounted. Contact THK for details.</p>																																						

A type with a wrap-around housing A and a motor wrap-around type, which are not contained in the catalog, are also available. Contact THK for details.

Model SKR20 Standard Type

Model SKR20□□A (with a Single Long Nut Block)

Model SKR20□□B (with Two Long Nut Blocks)

For model number coding, see **A2-28**.

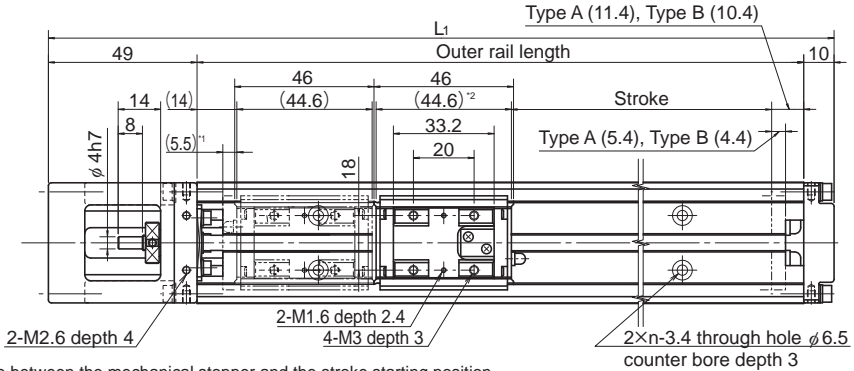

*1 Distance between the mechanical stopper and the stroke starting position.

*2 Indicates the inner block length when calculating the available stroke range. The length in model SKR-B (with two long-type inner blocks) is 90.6 mm.

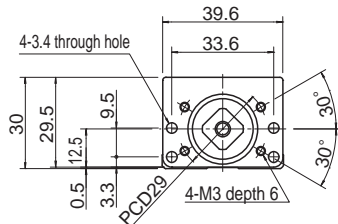
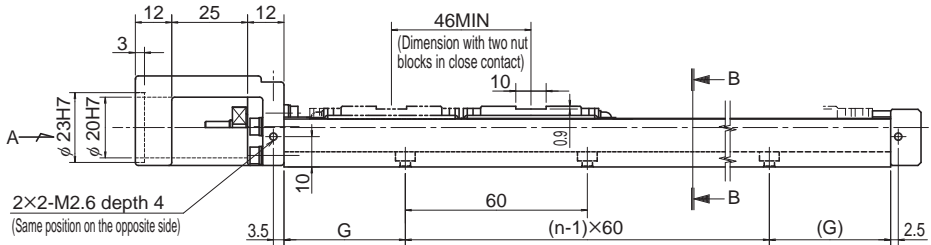

A arrow view

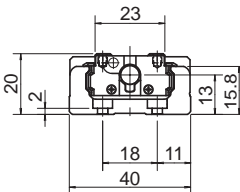

B-B cross section

Stroke (mm) (stroke between mechanical stoppers)		Outer rail length (mm)	Overall length L_1 (mm)	G (mm)	n	Overall main unit mass (kg)	
Type A	Type B					Type A	Type B
30(40.9)	—	100	159	20	2	0.45	—
80(90.9)	35(44.9)	150	209	15	3	0.58	0.66
130(140.9)	85(94.9)	200	259	40	3	0.72	0.8

*Indicates a value when two inner blocks are in close contact with each other.

Model SKR20 (with a Cover)

Model SKR20□□A (with a Single Long Nut Block)

Model SKR20□□B (with Two Long Nut Blocks)

For model number coding, see **A2-28**.

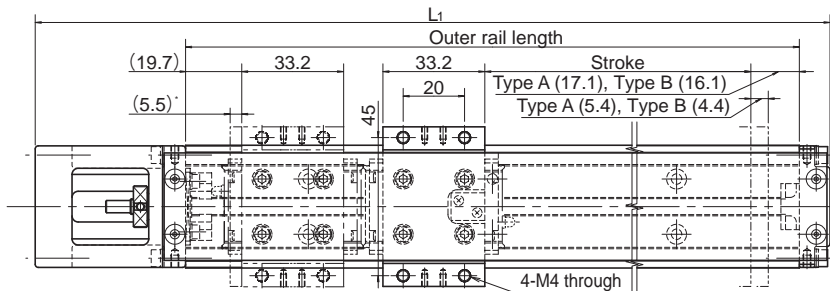

* Distance between the mechanical stopper and the stroke starting position.

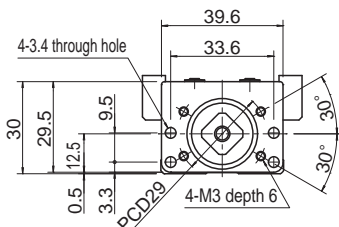
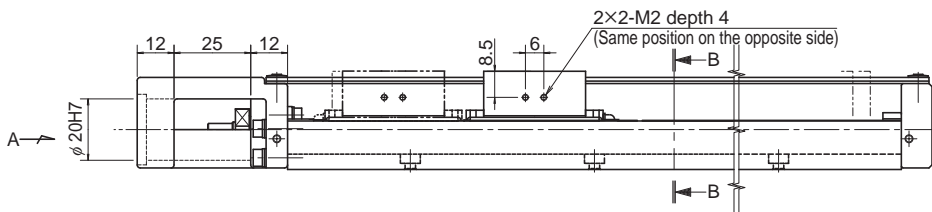

A arrow view

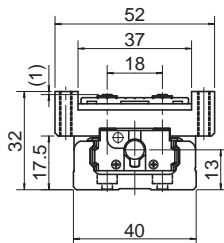

B-B cross section

Stroke (mm) (stroke between mechanical stoppers)		Outer rail length (mm)	Overall length L ₁ (mm)	G (mm)	n	Overall main unit mass (kg)	
Type A	Type B					Type A	Type B
30(40.9)	—	100	159	20	2	0.5	—
80(90.9)	35(44.9)	150	209	15	3	0.64	0.76
130(140.9)	85(94.9)	200	259	40	3	0.79	0.91

*Indicates a value when two inner blocks are in close contact with each other.

Model SKR26 Standard Type

Model SKR26□□A (with a Single Long Nut Block)

Model SKR26□□B (with Two Long Nut Blocks)

For model number coding, see **A2-28**.

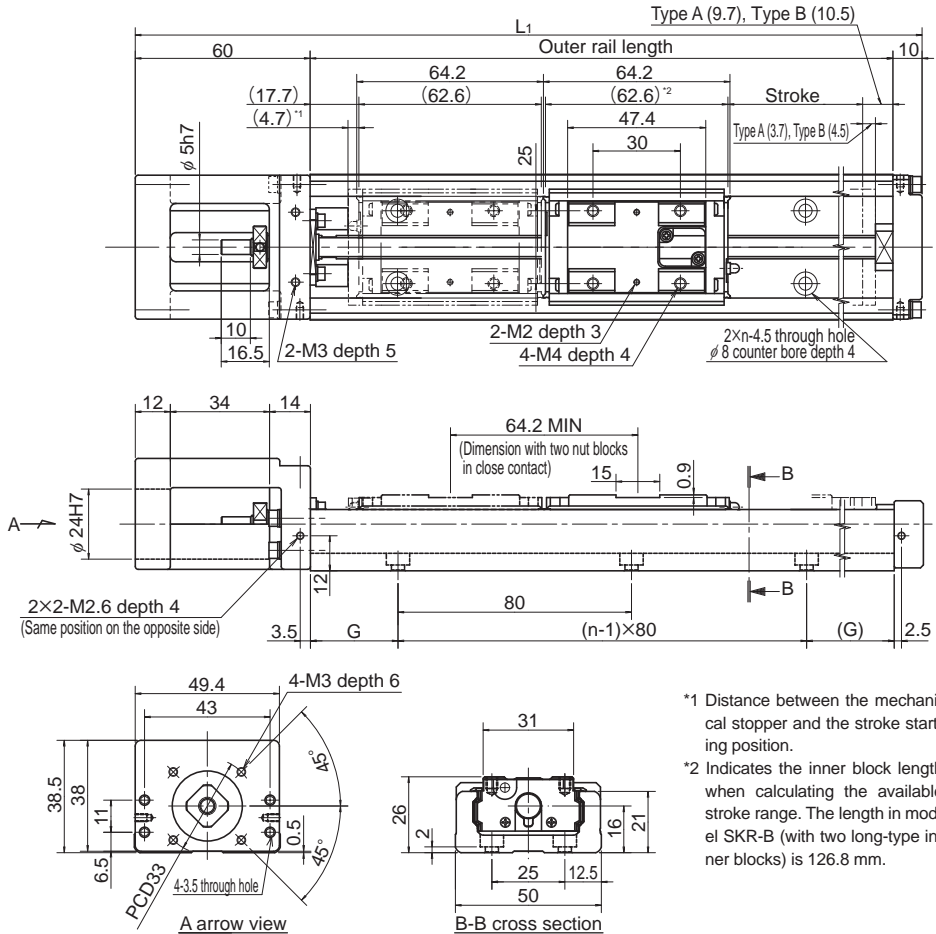

Stroke (mm) (stroke between mechanical stoppers)		Outer rail length (mm)	Overall length L_1 (mm)	G (mm)	n	Overall main unit mass (kg)	
Type A	Type B*					Type A	Type B
60(68.4)	—	150	220	35	2	0.99	—
110(118.4)	45(54.2)	200	270	20	3	1.2	1.38
160(168.4)	95(104.2)	250	320	45	3	1.41	1.59
210(218.4)	145(154.2)	300	370	30	4	1.62	1.8

*Indicates a value when two inner blocks are in close contact with each other.

Model SKR26 (with a Cover)

Model SKR26□□A (with a Single Long Nut Block)

Model SKR26□□B (with Two Long Nut Blocks)

For model number coding, see **A2-28**.

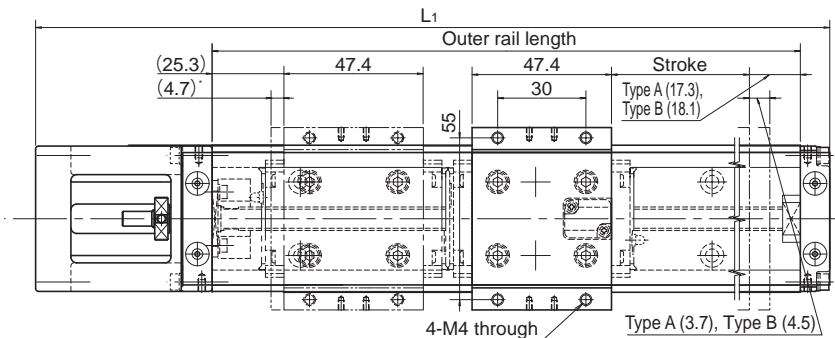

* Distance between the mechanical stopper and the stroke starting position.

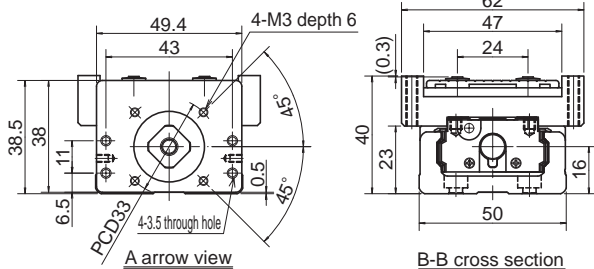
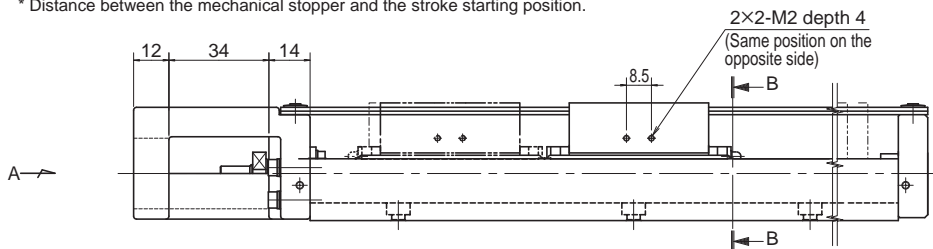

Stroke (mm) (stroke between mechanical stoppers)		Outer rail length (mm)	Overall length L ₁ (mm)	G (mm)	n	Overall main unit mass (kg)	
Type A	Type B*					Type A	Type B
60(68.4)	—	150	220	35	2	1.1	—
110(118.4)	45(54.2)	200	270	20	3	1.32	1.57
160(168.4)	95(104.2)	250	320	45	3	1.54	1.79
210(218.4)	145(154.2)	300	370	30	4	1.76	2.01

*Indicates a value when two inner blocks are in close contact with each other.

Model SKR33 Standard Type

Model SKR33□□A (with a Single Long Nut Block)

Model SKR33□□B (with Two Long Nut Blocks)

For model number coding, see **A2-28**.

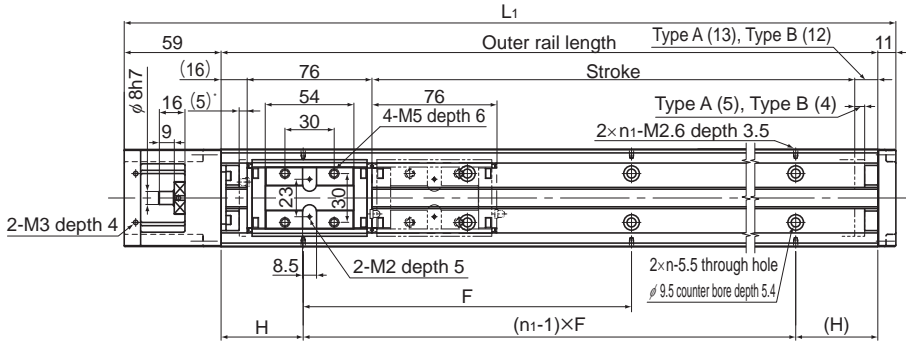

* Distance between the mechanical stopper and the stroke starting position.

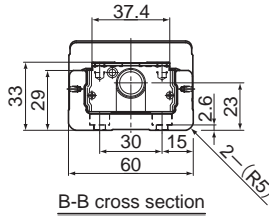
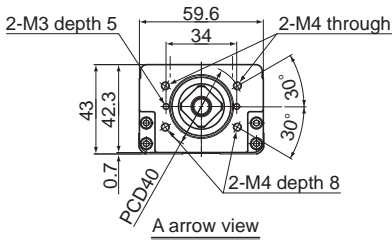
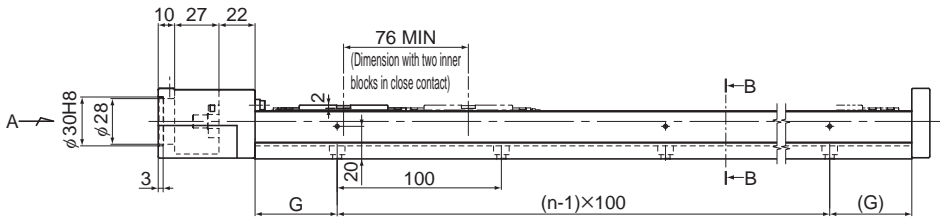

Stroke (mm) (stroke between mechanical stoppers)		Outer rail length (mm)	Overall length L ₁ (mm)	H (mm)	G (mm)	F (mm)	n	n ₁	Overall main unit mass (kg)	
Type A	Type B								Type A	Type B
45(55)	—	150	220	25	25	100	2	2	1.7	—
95(105)	—	200	270	50	50	100	2	2	2.1	—
195(205)	120(129)	300	370	50	50	200	3	2	2.8	3.1
295(305)	220(229)	400	470	100	50	200	4	2	3.5	3.8
395(405)	320(329)	500	570	50	50	200	5	3	4.2	4.5
495(505)	420(429)	600	670	100	50	200	6	3	5.0	5.3
595(605)	520(529)	700	770	50	50	200	7	4	5.7	6.0

*Indicates a value when two inner blocks are in close contact with each other.

Model SKR33 (with a Cover)

Model SKR33□□A (with a Single Long Nut Block)

Model SKR33□□B (with Two Long Nut Blocks)

For model number coding, see **A2-28**.

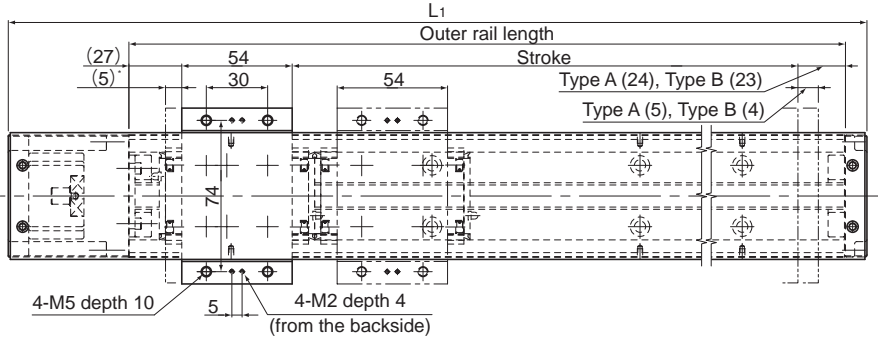

* Distance between the mechanical stopper and the stroke starting position.

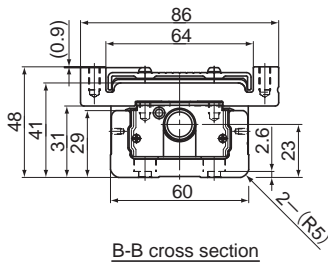
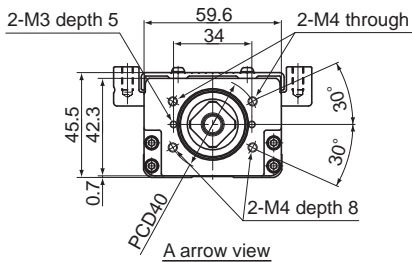
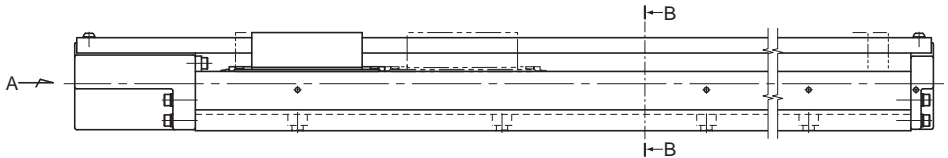

Stroke (mm) (stroke between mechanical stoppers)		Outer rail length (mm)	Overall length L_1 (mm)	H (mm)	G (mm)	F (mm)	n	n_1	Overall main unit mass (kg)	
Type A	Type B*								Type A	Type B
45(55)	—	150	220	25	25	100	2	2	1.9	—
95(105)	—	200	270	50	50	100	2	2	2.3	—
195(205)	120(129)	300	370	50	50	200	3	2	3.1	3.5
295(305)	220(229)	400	470	100	50	200	4	2	3.8	4.2
395(405)	320(329)	500	570	50	50	200	5	3	4.6	5.0
495(505)	420(429)	600	670	100	50	200	6	3	5.3	5.7
595(605)	520(529)	700	770	50	50	200	7	4	6.1	6.5

*Indicates a value when two inner blocks are in close contact with each other.

Model SKR33 Standard Type

Model SKR33□□C (with a Single Short Nut Block)

Model SKR33□□D (with Two Short Nut Blocks)

For model number coding, see **A2-28**.

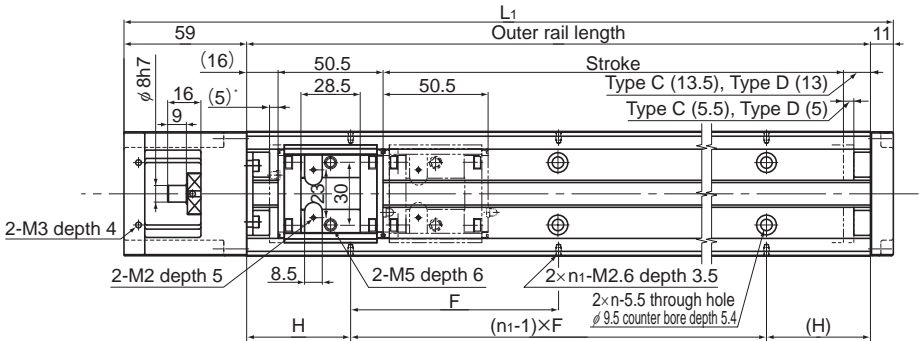

* Distance between the mechanical stopper and the stroke starting position.

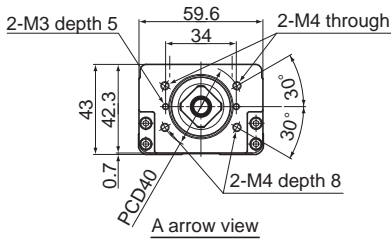
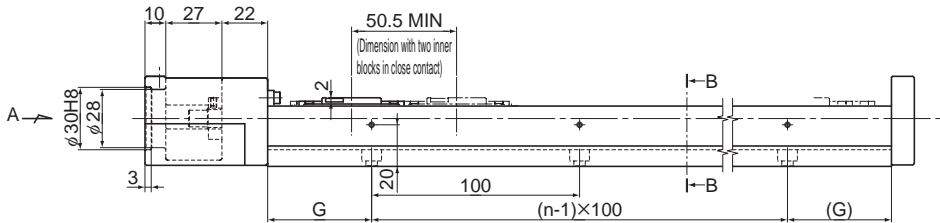

A arrow view

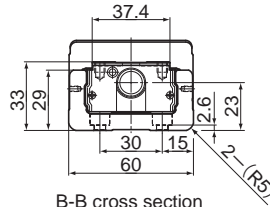

B-B cross section

Stroke (mm) (stroke between mechanical stoppers)		Outer rail length (mm)	Overall length L_1 (mm)	H (mm)	G (mm)	F (mm)	n	n_1	Overall main unit mass (kg)	
Type C	Type D								Type C	Type D
70(80.5)	20(30)	150	220	25	25	100	2	2	1.6	1.8
120(130.5)	70(80)	200	270	50	50	100	2	2	2.0	2.1
220(230.5)	170(180)	300	370	50	50	200	3	2	2.7	2.8
320(330.5)	270(280)	400	470	100	50	200	4	2	3.4	3.6
420(430.5)	370(380)	500	570	50	50	200	5	3	4.1	4.3
520(530.5)	470(480)	600	670	100	50	200	6	3	4.8	5.0
620(630.5)	570(580)	700	770	50	50	200	7	4	5.5	5.7

*Indicates a value when two inner blocks are in close contact with each other.

Model SKR33 (with a Cover)

Model SKR33□□C (with a Single Short Nut Block)

Model SKR33□□D (with Two Short Nut Blocks)

For model number coding, see **A2-28**.

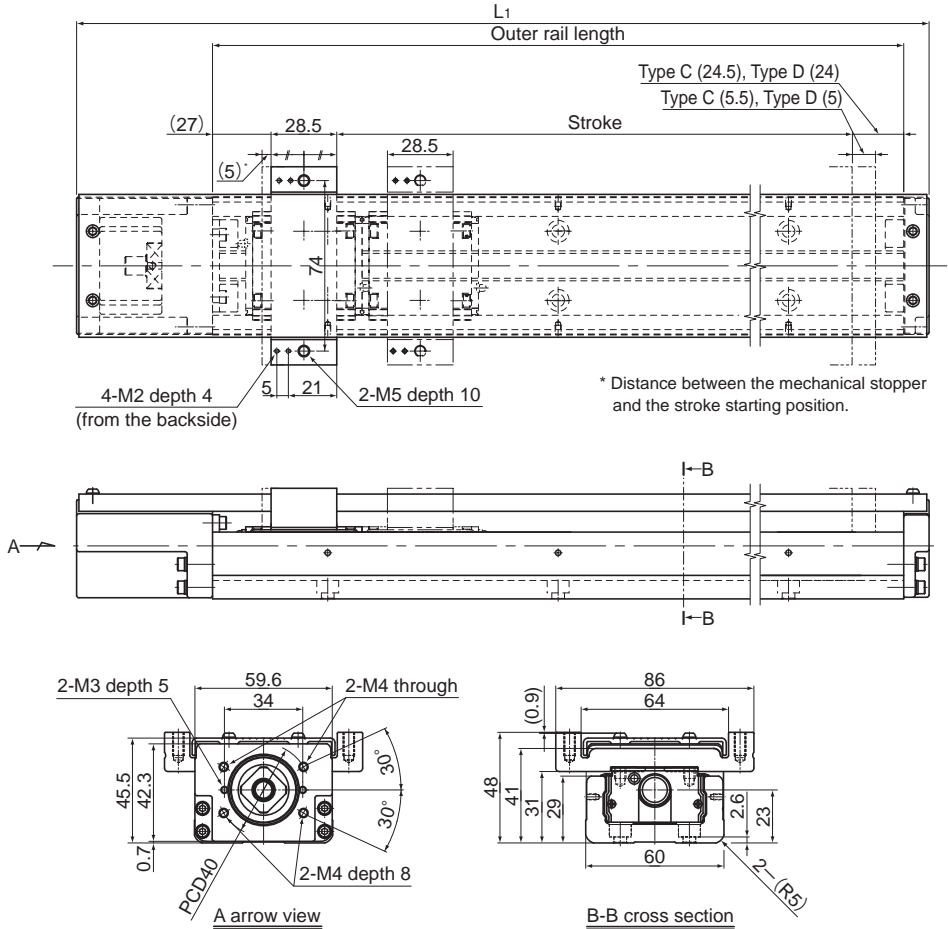

Stroke (mm) (stroke between mechanical stoppers)		Outer rail length (mm)	Overall length L (mm)	H (mm)	G (mm)	F (mm)	n	n ₁	Overall main unit mass (kg)	
Type C	Type D*								Type C	Type D
70(80.5)	20(30)	150	220	25	25	100	2	2	1.8	2.0
120(130.5)	70(80)	200	270	50	50	100	2	2	2.2	2.3
220(230.5)	170(180)	300	370	50	50	200	3	2	2.9	3.1
320(330.5)	270(280)	400	470	100	50	200	4	2	3.7	3.8
420(430.5)	370(380)	500	570	50	50	200	5	3	4.4	4.6
520(530.5)	470(480)	600	670	100	50	200	6	3	5.2	5.3
620(630.5)	570(580)	700	770	50	50	200	7	4	5.9	6.1

*Indicates a value when two inner blocks are in close contact with each other.

Model SKR46 Standard Type

Model SKR46□□A (with a Single Long Nut Block)

Model SKR46□□B (with Two Long Nut Blocks)

For model number coding, see **A2-28**.

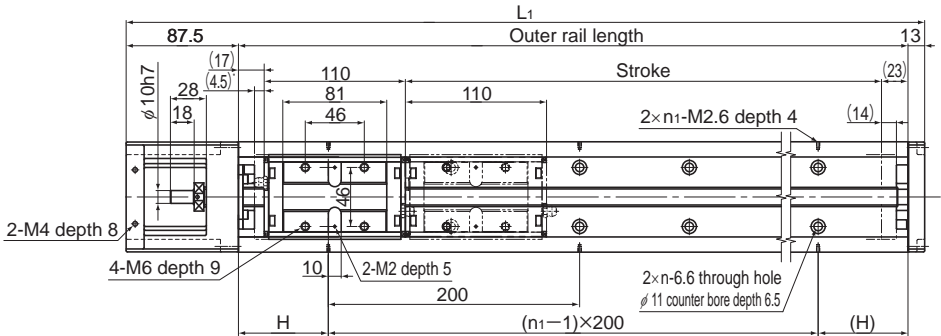

* Distance between the mechanical stopper and the stroke starting position.

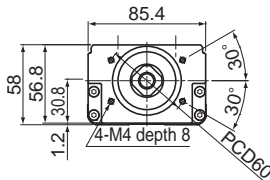
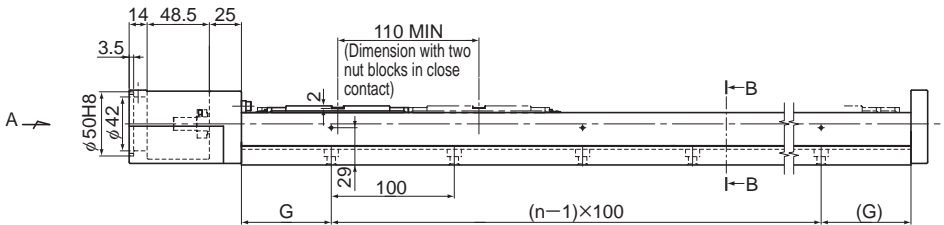

A arrow view

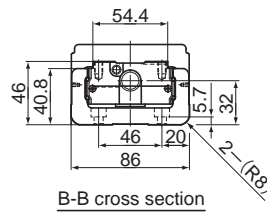

B-B cross section

Stroke (mm) (stroke between mechanical stoppers)		Outer rail length (mm)	Overall length L_1 (mm)	H (mm)	G (mm)	n	n_1	Overall main unit mass (kg)	
Type A	Type B							Type A	Type B
190(208.5)	80(98.5)	340	440.5	70	70	3	2	6.4	7.4
290(308.5)	180(198.5)	440	540.5	20	70	4	3	7.8	8.7
390(408.5)	280(298.5)	540	640.5	70	70	5	3	9.2	10.1
490(508.5)	380(398.5)	640	740.5	20	70	6	4	10.6	11.5
590(608.5)	480(498.5)	740	840.5	70	70	7	4	12.0	12.9
690(708.5)	580(598.5)	840	940.5	20	70	8	5	13.4	14.4
790(808.5)	680(698.5)	940	1040.5	70	70	9	5	14.8	15.7

*Indicates a value when two inner blocks are in close contact with each other.

Model SKR46 (with a Cover)

Model SKR46□□A (with a Single Long Nut Block)

Model SKR46□□B (with Two Long Nut Blocks)

For model number coding, see **A2-28**.

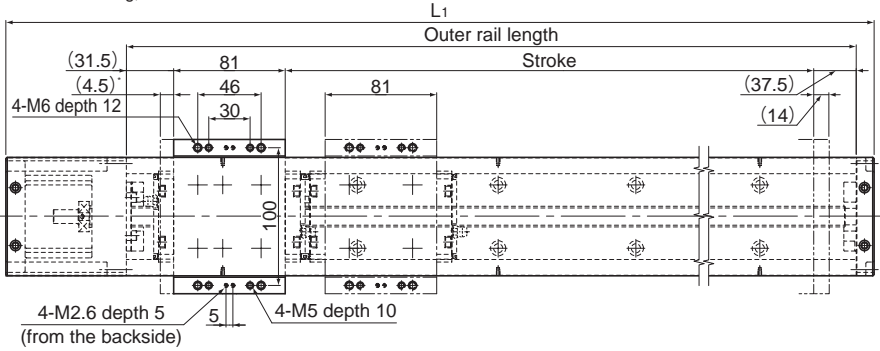

* Distance between the mechanical stopper and the stroke starting position.

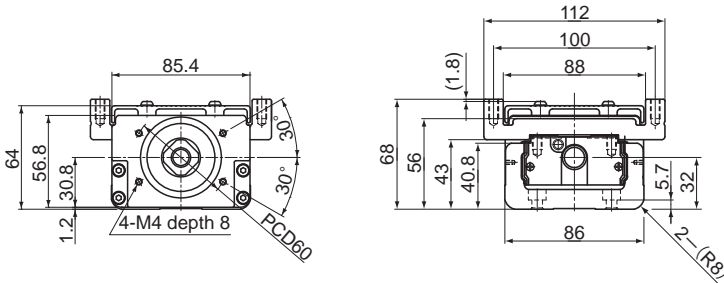
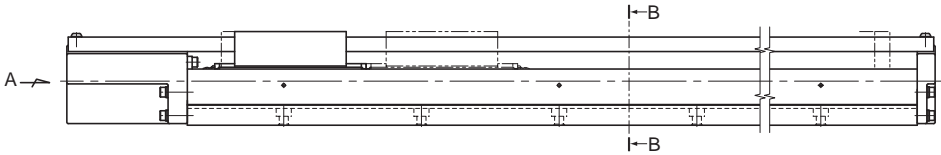

A arrow view

B-B cross section

Stroke (mm) (stroke between mechanical stoppers)		Outer rail length (mm)	Overall length L_1 (mm)	H (mm)	G (mm)	n	n_1	Overall main unit mass (kg)	
Type A	Type B*							Type A	Type B
190(208.5)	80(98.5)	340	440.5	70	70	3	2	7.1	8.3
290(308.5)	180(198.5)	440	540.5	20	70	4	3	8.6	9.8
390(408.5)	280(298.5)	540	640.5	70	70	5	3	10.0	11.3
490(508.5)	380(398.5)	640	740.5	20	70	6	4	11.5	12.7
590(608.5)	480(498.5)	740	840.5	70	70	7	4	13.0	14.2
690(708.5)	580(598.5)	840	940.5	20	70	8	5	14.5	15.7
790(808.5)	680(698.5)	940	1040.5	70	70	9	5	16.0	17.2

*Indicates a value when two inner blocks are in close contact with each other.

Model SKR46 (with a Cover)

Model SKR46□□C (with a Single Short Nut Block)

Model SKR46□□D (with Two Short Nut Blocks)

For model number coding, see **A2-28**.

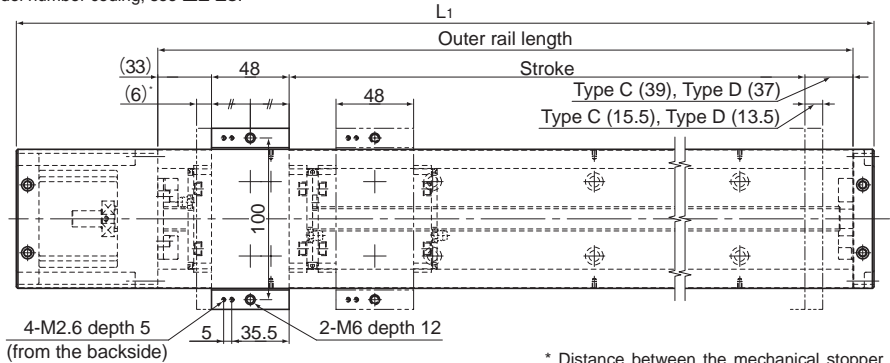

* Distance between the mechanical stopper and the stroke starting position.

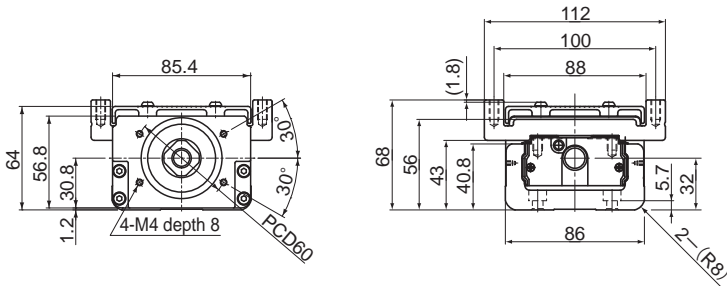
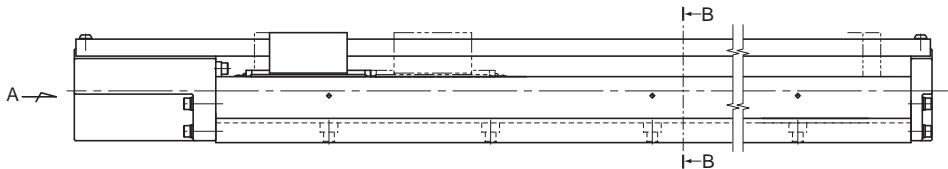

A arrow view

B-B cross section

Stroke (mm) (stroke between mechanical stoppers)		Outer rail length (mm)	Overall length L_1 (mm)	H (mm)	G (mm)	n	n_1	Overall main unit mass (kg)	
Type C	Type D*							Type C	Type D
220(241.5)	145(164.5)	340	440.5	70	70	3	2	6.6	7.4
320(341.5)	245(264.5)	440	540.5	20	70	4	3	8.1	8.9
420(441.5)	345(364.5)	540	640.5	70	70	5	3	9.6	10.3
520(541.5)	445(464.5)	640	740.5	20	70	6	4	11.0	11.8
620(641.5)	545(564.5)	740	840.5	70	70	7	4	12.5	13.3
720(741.5)	645(664.5)	840	940.5	20	70	8	5	14	14.8
820(841.5)	745(764.5)	940	1040.5	70	70	9	5	15.5	16.3

*Indicates a value when two inner blocks are in close contact with each other.

Model SKR55 Standard Type

Model SKR55□□A (with a Single Long Nut Block)

Model SKR55□□B (with Two Long Nut Blocks)

For model number coding, see **A2-28**.

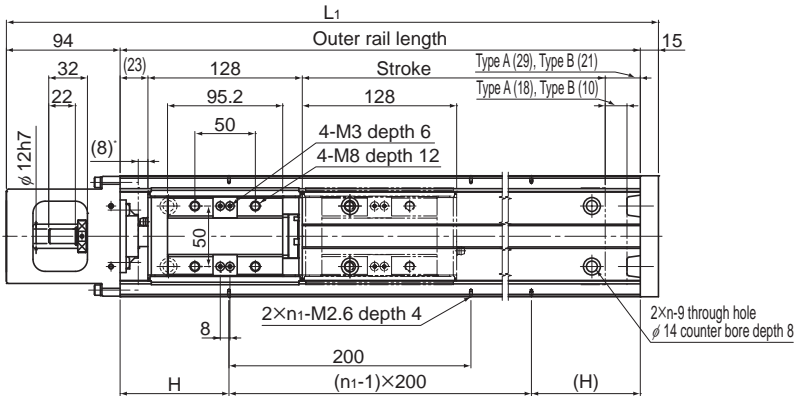

* Distance between the mechanical stopper and the stroke starting position.

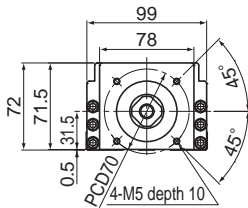
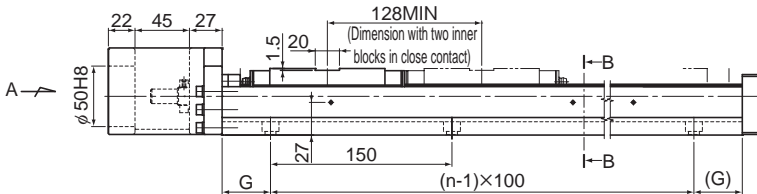

A arrow view

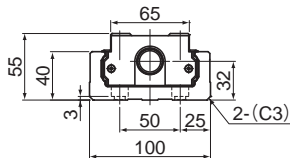

B-B cross section

Stroke (mm) (stroke between mechanical stoppers)		Outer rail length (mm)	Overall length L_1 (mm)	H (mm)	G (mm)	n	n_1	Overall main unit mass (kg)	
Type A	Type B*							Type A	Type B
800 (826)	680 (698)	980	1089	90	40	7	5	20.8	22.7
900 (926)	780 (798)	1080	1189	40	15	8	6	22.6	24.5
1000 (1026)	880 (898)	1180	1289	90	65	8	6	24.4	26.3
1100 (1126)	980 (998)	1280	1389	40	40	9	7	26.1	28
1200 (1226)	1080 (1098)	1380	1489	90	15	10	7	27.9	29.8

*Indicates a value when two inner blocks are in close contact with each other.

Model SKR55 (with a Cover)

Model SKR55□□A (with a Single Long Nut Block)

Model SKR55□□B (with Two Long Nut Blocks)

For model number coding, see **A2-28**.

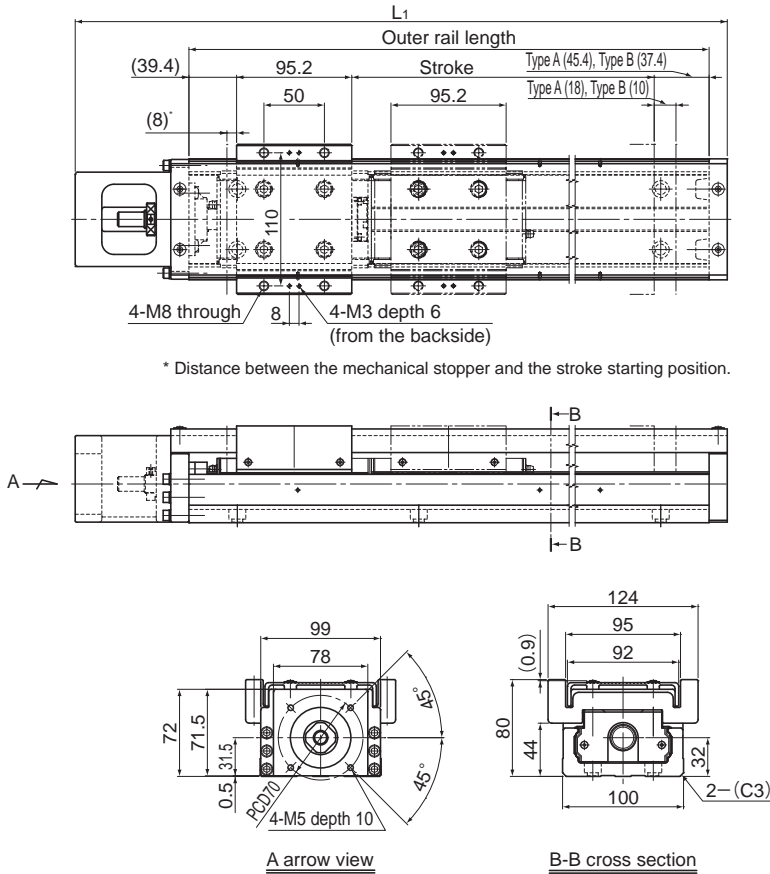

Stroke (mm) (stroke between mechanical stoppers)		Outer rail length (mm)	Overall length L ₁ (mm)	Overall main unit mass (kg)	
Type A	Type B*			Type A	Type B
800 (826)	680 (698)	980	1089	23.8	27.6
900 (926)	780 (798)	1080	1189	25.7	29.5
1000 (1026)	880 (898)	1180	1289	27.6	31.4
1100 (1126)	980 (998)	1280	1389	29.5	33.3
1200 (1226)	1080 (1098)	1380	1489	31.4	35.2

*Indicates a value when two inner blocks are in close contact with each other.

Model SKR65 Standard Type

Model SKR65□□A (with a Single Long Nut Block)

Model SKR65□□B (with Two Long Nut Blocks)

For model number coding, see **A2-28**.

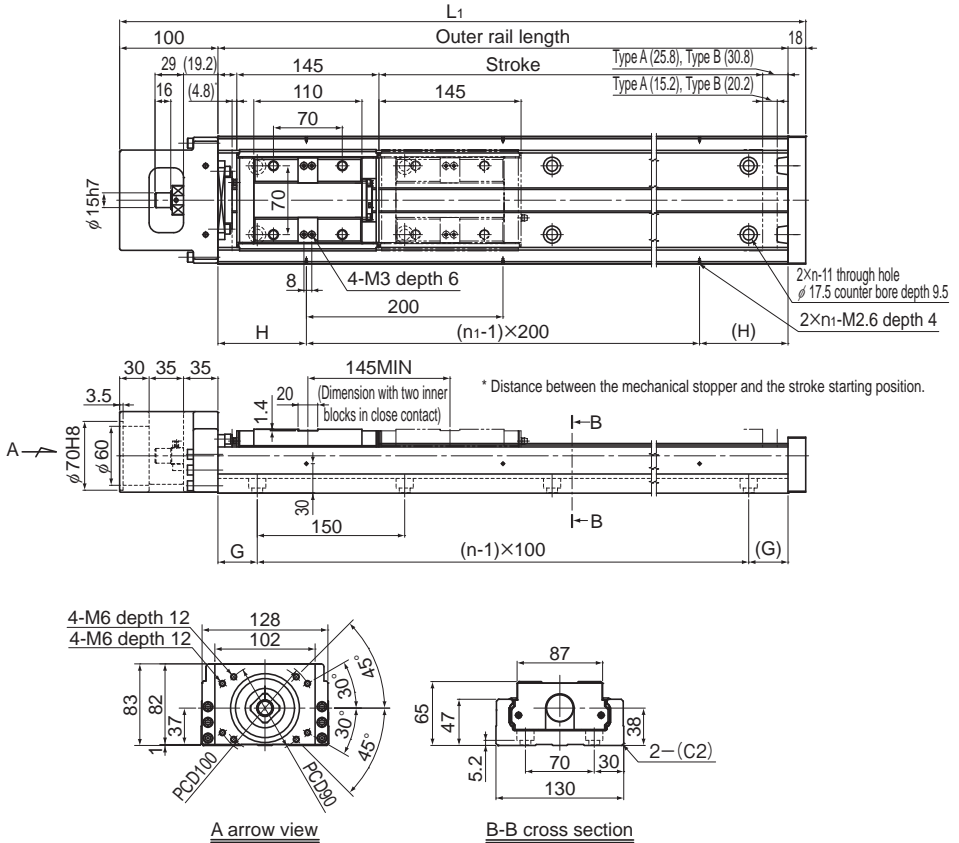

Stroke (mm) (stroke between mechanical stoppers)		Outer rail length (mm)	Overall length L_1 (mm)	H (mm)	G (mm)	n	n_1	Overall main unit mass (kg)	
Type A	Type B*							Type A	Type B
790 (810)	640 (665)	980	1098	90	40	7	5	30.2	33.2
990 (1010)	840 (865)	1180	1298	90	65	8	6	35.4	38.4
1190 (1210)	1040 (1065)	1380	1498	90	90	9	7	40.6	43.6
1490 (1510)	1340 (1365)	1680	1798	40	90	11	9	48.3	51.3

*Indicates a value when two inner blocks are in close contact with each other.

Model SKR65 (with a Cover)

Model SKR65□□A (with a Single Long Nut Block)

Model SKR65□□B (with Two Long Nut Blocks)

For model number coding, see **A2-28**.

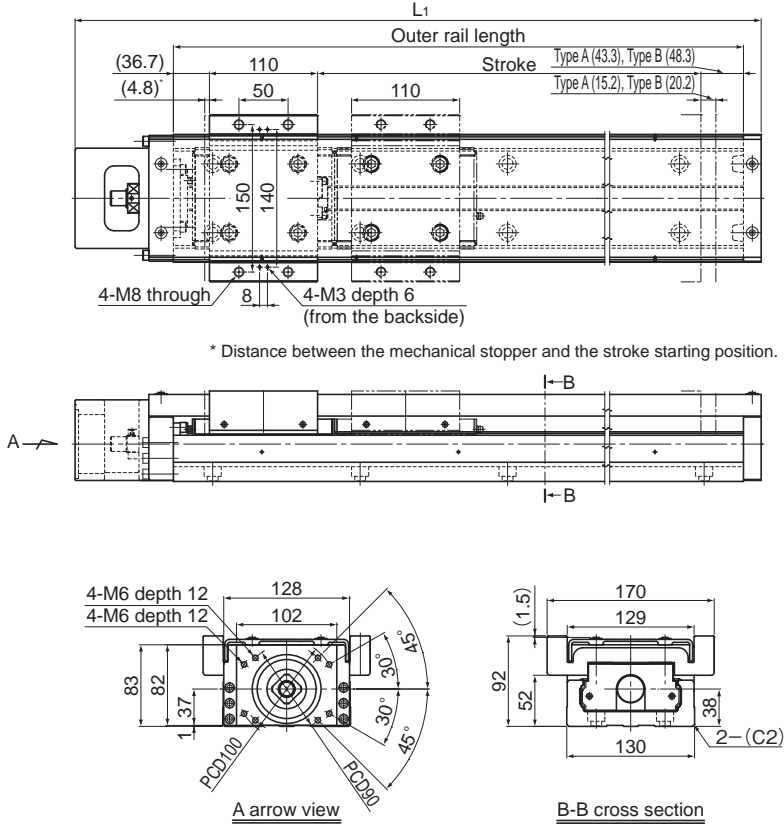

Stroke (mm) (stroke between mechanical stoppers)		Outer rail length (mm)	Overall length L ₁ (mm)	Overall main unit mass (kg)	
Type A	Type B*			Type A	Type B
790 (810)	640 (665)	980	1098	33.4	40.1
990 (1010)	840 (865)	1180	1298	38.9	45.6
1190 (1210)	1040 (1065)	1380	1498	44.3	51
1490 (1510)	1340 (1365)	1680	1798	52.4	59.1

*Indicates a value when two inner blocks are in close contact with each other.

Mass of Moving Element

Table14 shows the mass of the inner block and top table of model SKR.

Table14 Mass of the Inner Block and Top table of SKR

Unit: kg

Model No.	Long nut block types (A)		Short nut block types (C)	
	Inner block	Top table	Inner block	Top table
SKR20	0.064	0.038	—	—
SKR26	0.153	0.074	—	—
SKR33	0.31	0.13	0.17	0.07
SKR46	0.91	0.34	0.57	0.20
SKR55	1.9	1.9	—	—
SKR65	3.0	3.5	—	—



SKSSWEDEN