

# Precision, Caged Ball Screw



Models SBN, SBK, SDA, HBN and SBKH

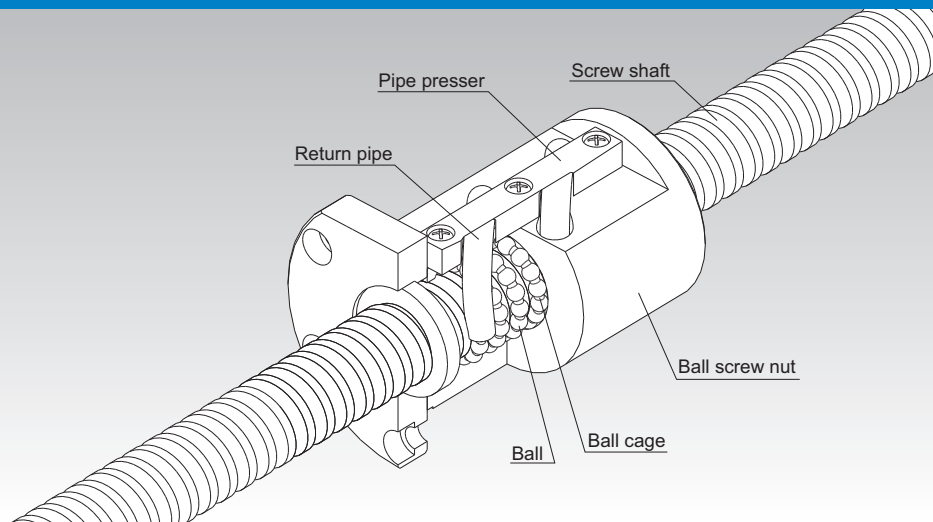

Fig.1 Structure of High-Speed Ball Screw with Ball Cage Model SBN

<b>Point of Selection</b>	<b>A15-8</b>
<b>Options</b>	<b>A15-352</b>
<b>Model No.</b>	<b>A15-369</b>
<b>Precautions on Use</b>	<b>A15-374</b>
<b>Accessories for Lubrication</b>	<b>A24-1</b>
<b>Mounting Procedure and Maintenance</b>	<b>B15-104</b>
Lead Angle Accuracy	A15-11
Accuracy of the Mounting Surface	A15-14
Axial Clearance	A15-19
Maximum Length of the Screw Shaft	A15-24
DN Value	A15-33
Support Unit	A15-316
Recommended Shapes of Shaft Ends	A15-324
Dimensions of Each Model with an Option Attached	A15-360

## Structure and Features

The use of a ball cage in the Ball Screw with the Ball Cage eliminates collision and friction between balls and increases the grease retention. This makes it possible to achieve a low noise, a low torque fluctuation and a long-term maintenance-free operation.

In addition, this Ball Screw is superbly capable of responding to the high speed because of an ideal ball recirculation structure, a strengthened circulation path and an adoption of the ball cage.

## Ball Cage Effect

### [Low Noise, Acceptable Running Sound]

The use of the ball cage eliminates the collision noise between the balls. Additionally, as balls are picked up in the tangential direction, the collision noise from the ball circulation has also been eliminated.

### [Long-term Maintenance-free Operation]

The friction between the balls has been eliminated, and the grease retention has been improved through the provision of grease pockets. As a result, the long-term maintenance-free operation (i.e., lubrication is unnecessary over a long period) is achieved.

### [Smooth Motion]

The use of a ball cage eliminates the friction between the balls and minimizes the torque fluctuation, thus allowing the smooth motion to be achieved.

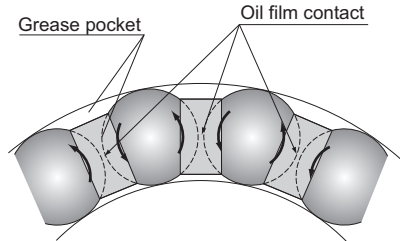
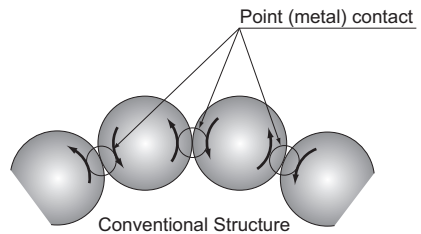

Structure of the Ball Screw with Ball Cage

## [Low Noise]

### ● Noise Level Data

Since the balls in the Ball Screw with the Ball Cage do not collide with each other, they do not produce a metallic sound and a low noise level is achieved.

### ■ Noise Measurement

[Conditions]

Item	Description
Sample	High load ball screw with ball cage HBN3210-5 Conventional type: model BNF3210-5
Stroke	600mm
Lubrication	Grease lubrication (lithium-based grease containing extreme pressure agent)

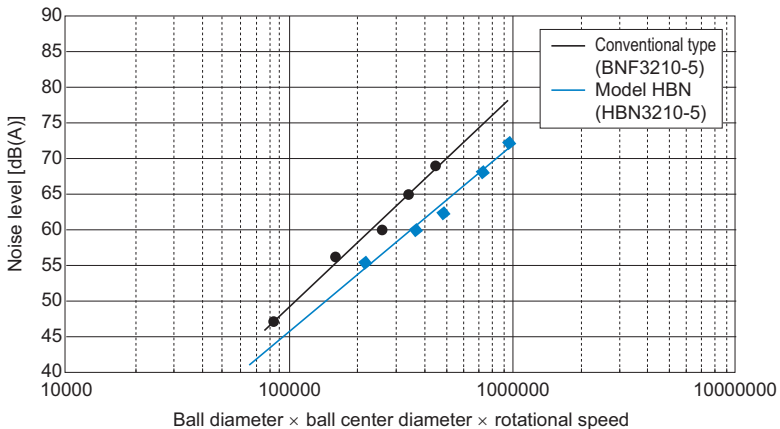
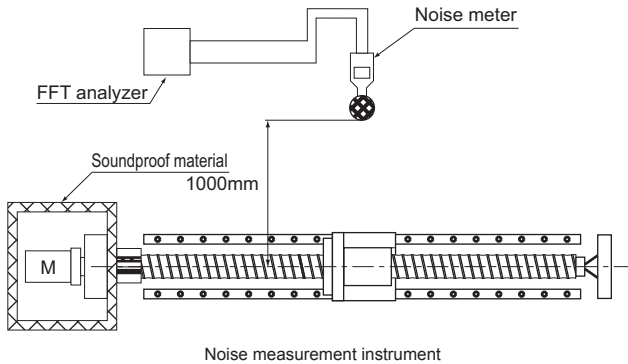

Fig.2 Ball Screw Noise Level

### [Long-term Maintenance-free Operation]

#### ● High speed, Load-bearing Capacity

Thanks to the ball circulating method supporting high speed and the caged ball technology, the Ball Screw with Ball Cage excels in high speed and load-bearing capacity.

#### ■ High Speed Durability Test

[Test conditions]

Item	Description
Sample	High Speed Ball Screw with Ball Cage SBN3210-7
Speed	3900( $\text{min}^{-1}$ )(DN value*: 130,000)
Stroke	400mm
Lubricant	THK AFG Grease
Quantity	12 $\text{cm}^3$ (lubricated every 1000km)
Applied load	1.73kN
Acceleration	1G

\* DN value: Ball center-to-center diameter x revolutions per minute

[Test result]

Shows no deviation after running 10,000 km.

#### ■ Load Bearing Test

[Test conditions]

Item	Description
Sample	High Speed Ball Screw with Ball Cage SBN3210-7
Speed	1500( $\text{min}^{-1}$ )(DN value*: 50,000)
Stroke	300mm
Lubricant	THK AFG Grease
Quantity	12 $\text{cm}^3$
Applied load	17.3kN(0.5Ca)
Acceleration	0.5G

[Test result]

Shows no deviation after running a distance 2.5 times the calculated service life.

### [Smooth Motion]

#### ● Low Torque Fluctuation

The caged ball technology allows smoother motion than the conventional type to be achieved, thus to reduce torque fluctuation.

[Conditions]

Item	Description
Shaft diameter/lead	32/10mm
Shaft rotational speed	60 $\text{min}^{-1}$

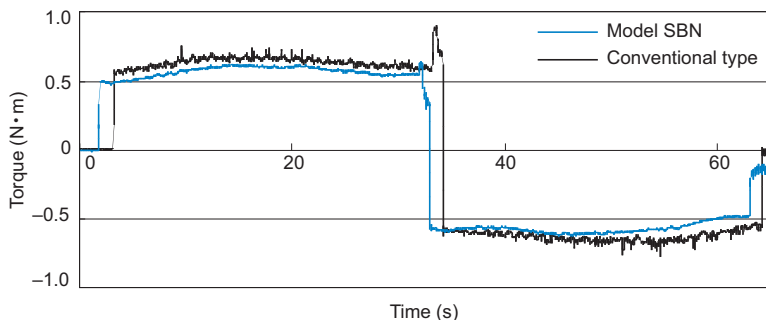

Fig.3 Torque Fluctuation Data

## Types and Features

[Preload Type]

### Model SBN

Specification Table⇒ **A15-70**

Model SBN has a circulation structure where balls are picked up in the tangential direction and is provided with a strengthened circulation path, thus to achieve a DN value of 130,000.

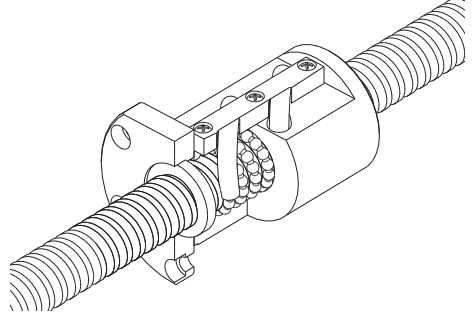

### Model SBK

Specification Table⇒ **A15-74**

As a result of adopting the offset preloading method, which shifts two rows of grooves of the ball screw nut, a compact structure is achieved.

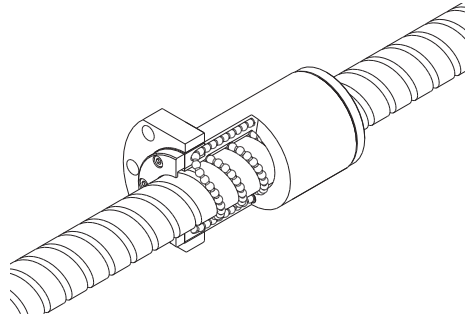

[No Preload Type]

### Model SDA

Specification Table⇒ **A15-78**

Model SDA achieves an ideal ball circulation structure and a significantly compact body by using newly developed end cap and R piece.

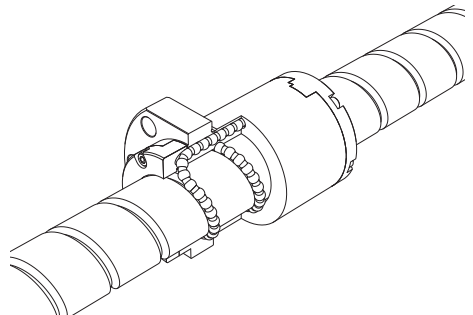

## Model HBN

With the optimal design for high loads, this Ball Screw model achieves a rated load more than twice the conventional type.

Specification Table⇒ **A15-80**

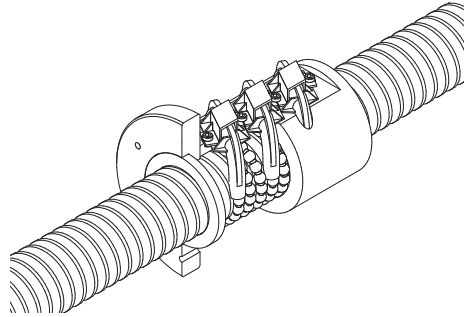

## Model SBKH

Model SBKH is a ball screw that achieves a high load carrying capacity and is capable of high-speed operation (92 m/min at a maximum).

Specification Table⇒ **A15-82**

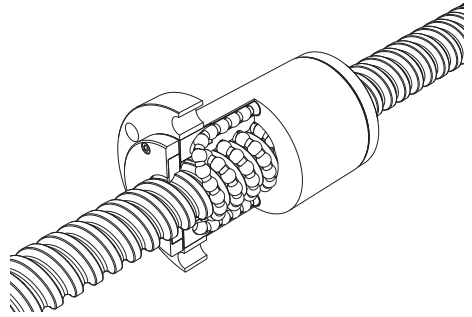

## Examples of Assembling Models HBN and SBKH

If using model HBN or SBKH under a large load, arrange the nut flange and the fixed-side support unit in relation to the loading direction as indicated in the figure below while taking into account the load balance of the balls. In addition, while HBN or SBKH is operating, be sure not to apply a tensile load to the bolts. If you intend to use HBN or SBKH in configurations other than below, contact THK.

### [Examples of Recommended Assembly of Models HBN and SBKH]

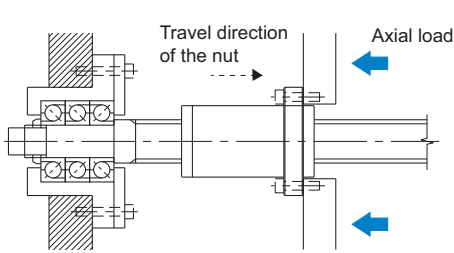

Good example (with the nut moving)

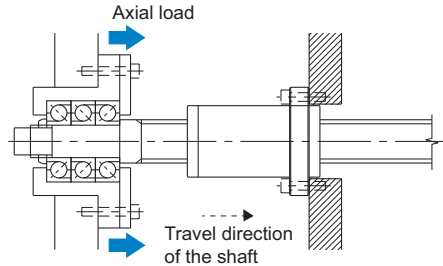

Good example (with the shaft moving)

### [Examples of Un-recommended Assembly of Models HBN and SBKH]

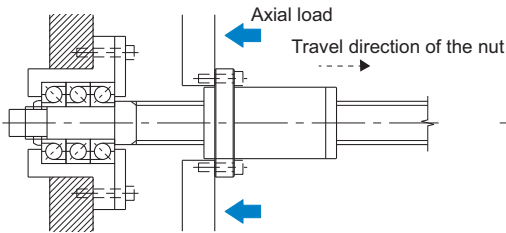

Bad example (with the nut moving)

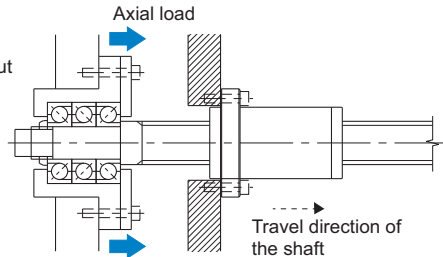

Bad example (with the shaft moving)





# Model SBN

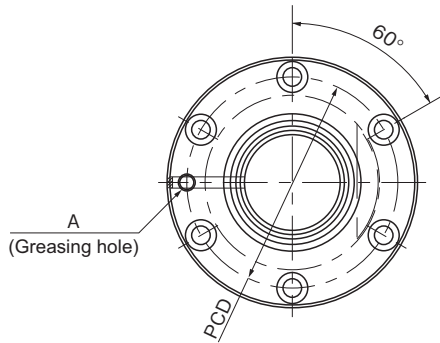

Model No.	Screw shaft outer diameter d	Lead Ph	Ball center-to-center diameter dp	Thread minor diameter dc	No. of loaded circuits Rows X turns	Basic load rating		Rigidity K N/μm
						Ca kN	C <sub>0a</sub> kN	
SBN 1604-5	16	4	16.5	13.8	1×2.5	5.3	8	281
SBN 1605-5	16	5	16.75	13.2	1×2.5	9.2	12.9	309
SBN 2004-5	20	4	20.5	17.8	1×2.5	5.9	10.1	335
SBN 2005-5	20	5	20.75	17.2	1×2.5	10.3	16.2	370
SBN 2504-5	25	4	25.5	22.8	1×2.5	6.4	12.7	400
SBN 2505-5	25	5	25.75	22.2	1×2.5	11.3	20.3	442
SBN 2506-5	25	6	26	21.4	1×2.5	15.4	25.4	457
SBN 2805-5	28	5	28.75	25.2	1×2.5	11.8	22.8	483
SBN 2806-5	28	6	29	24.4	1×2.5	16.2	28.5	499
SBN 3205-5	32	5	32.75	29.2	1×2.5	12.6	26.1	536
SBN 3206-5	32	6	33	28.4	1×2.5	17.2	32.7	555

Note) With model SBN, the raising of both ends of the thread groove is not available. When designing your system this way, contact THK.

Axial Clearance

Unit: mm

Clearance symbol	G0
Axial Clearance	0 or less

## Model number coding

**SBN1604-5 QZ RR G0 +1200L C5**

Model Number

Seal symbol (\*1)

Accuracy symbol (\*2)

With QZ Lubricator  
(no symbol if the model  
is without a QZ Lubricator)

Overall screw shaft length (in mm)  
Symbol for Clearance in the axial direction  
(G0 for all SBN variations)

(\*1) See **A15-352**. (\*2) See **A15-12**.



# Model SBN

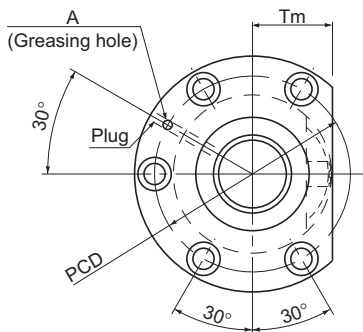

Model No.	Screw shaft outer diameter d	Lead Ph	Ball center-to-center diameter dp	Thread minor diameter dc	No. of loaded circuits Rows x turns	Basic load rating		Rigidity K N/μm
						Ca kN	C <sub>0a</sub> kN	
○ SBN 3210-7	32	10	33.75	26.4	1×3.5	43	73.1	836.7
○ SBN 3212-5	32	12	34	26.1	1×2.5	37.4	58.7	612.2
○ SBN 3610-7	36	10	37.75	30.4	1×3.5	45.6	82.3	920.9
○ SBN 3612-7	36	12	38	30.1	1×3.5	53.2	92.6	934.5
○ SBN 3616-5	36	16	38	30.1	1×2.5	39.7	66.4	676
○ SBN 4012-5	40	12	42	34.1	1×2.5	42	73.6	735.4
○ SBN 4016-5	40	16	42	34.1	1×2.5	41.9	73.8	736.6
○ SBN 4512-5	45	12	47	39.2	1×2.5	44.4	82.9	809.1
○ SBN 4516-5	45	16	47	39.2	1×2.5	44.3	83.1	810.1
○ SBN 5012-5	50	12	52	44.1	1×2.5	46.6	92.2	880.9
○ SBN 5016-5	50	16	52	44.1	1×2.5	46.6	92.4	881.7
○ SBN 5020-5	50	20	52	44.1	1×2.5	46.5	92.6	882.8

Note) With model SBN, the raising of both ends of the thread groove is not available. When designing your system this way, contact THK.

Those models marked with ○ can be attached with QZ Lubricator or the wiper ring. For dimensions of the ball screw nut with either accessory being attached, see [A15-360](#).

Axial Clearance

Unit: mm

Clearance symbol	G0
Axial Clearance	0 or less

## Model number coding

**SBN4012-5 RR G0 +1400L C5**

Model number    Seal symbol (\*1)    Overall screw shaft length (in mm)    Accuracy symbol (\*2)

Symbol for Clearance in the axial direction  
(G0 for all SBN variations)

(\*1) See [A15-352](#). (\*2) See [A15-12](#).

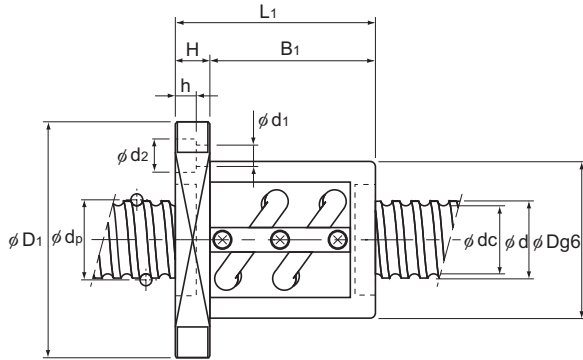

Unit: mm

	Nut dimensions									Screw shaft inertial moment/mm kg·cm <sup>2</sup> /mm	Nut mass kg	Shaft mass kg/m
	Outer diameter	Flange diameter	Overall length	H	B <sub>1</sub>	PCD	d <sub>1</sub> × d <sub>2</sub> × h	Tm	Greasing hole			
	D	D <sub>1</sub>	L <sub>1</sub>	H	B <sub>1</sub>	PCD	d <sub>1</sub> × d <sub>2</sub> × h	Tm	A			
	74	108	120	15	105	90	9 × 14 × 8.5	38	M6	8.08 × 10 <sup>-3</sup>	3.1	3.6
	76	121	117	18	99	98	11 × 17.5 × 11	39	M6	8.08 × 10 <sup>-3</sup>	3.7	3.5
	77	120	123	18	105	98	11 × 17.5 × 11	40	M6	1.29 × 10 <sup>-2</sup>	3.8	5.0
	81	124	140	18	122	102	11 × 17.5 × 11	42	M6	1.29 × 10 <sup>-2</sup>	4.7	4.8
	81	124	140	18	122	102	11 × 17.5 × 11	42	M6	1.29 × 10 <sup>-2</sup>	4.7	5.6
	84	126	119	18	101	104	11 × 17.5 × 11	43	M6	1.97 × 10 <sup>-2</sup>	4.2	6.4
	84	126	144	18	126	104	11 × 17.5 × 11	43	M6	1.97 × 10 <sup>-2</sup>	4.9	7.3
	90	130	119	18	101	110	11 × 17.5 × 11	46	PT 1/8	3.16 × 10 <sup>-2</sup>	4.6	8.6
	90	130	140	18	122	110	11 × 17.5 × 11	46	PT 1/8	3.16 × 10 <sup>-2</sup>	5.3	9.6
	95	141	119	22	97	117	14 × 20 × 13	48	PT 1/8	4.82 × 10 <sup>-2</sup>	5.3	11.1
	95	141	143	22	121	117	14 × 20 × 13	48	PT 1/8	4.82 × 10 <sup>-2</sup>	6.1	12.2
	95	141	169	22	147	117	14 × 20 × 13	48	PT 1/8	4.82 × 10 <sup>-2</sup>	7.0	12.8

Note) The rigidity values in the table represent the spring constants obtained from the load and the elastic deformation when providing a preload 10% of the basic dynamic load rating (Ca) and applying an axial load three times greater than the preload.

These values do not include the rigidity of the components related to mounting the ball screw nut. Therefore, it is normally appropriate to regard roughly 80% of the value in the table as the actual value.

If the applied preload (Fa<sub>0</sub>) is not 0.1 Ca, the rigidity value (K<sub>v</sub>) is obtained from the following equation.

$$K_v = K \left( \frac{F_{a0}}{0.1C_a} \right)^{\frac{1}{3}}$$

K: Rigidity value in the dimensional table.

# Model SBK

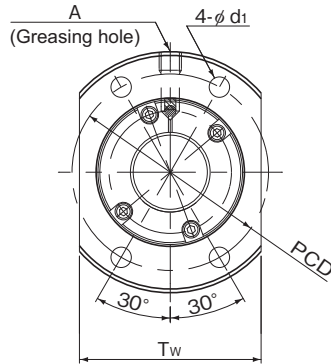

Model No.	Screw shaft outer diameter d	Lead Ph	Ball center-to-center diameter d <sub>p</sub>	Thread minor diameter d <sub>c</sub>	No. of loaded circuits Rows × turns	Basic load rating		Rigidity K N/μm
						Ca kN	C <sub>0a</sub> kN	
SBK 1520-3.6	15	20	15.75	12.2	1×1.8	5.8	7.8	178
SBK 1616-3.6	16	16	16.65	13.5	1×1.8	4.6	6.4	182
SBK 2010-5.6	20	10	20.75	17.2	1×2.8	10.7	17.3	353
SBK 2020-3.6	20	20	20.75	17.2	1×1.8	7	10.5	229
SBK 2030-3.6	20	30	20.75	17.2	1×1.8	6.9	11.2	236
SBK 2520-3.6	25	20	26	21.5	1×1.8	11	16.9	292
SBK 2525-3.6	25	25	26	21.5	1×1.8	10.8	16.9	290
SBK 3220-5.6	32	20	33.25	27.9	1×2.8	23.6	41.1	565
SBK 3232-5.6	32	32	33.25	27.9	1×2.8	23.1	41.8	567

Axial Clearance

Unit: mm

Clearance symbol	G0
Axial Clearance	0 or less

## Model number coding

**SBK2525-3.6 QZ G0 +1200L C5**

Model Number

Overall screw shaft  
length (in mm)

Accuracy symbol (\*1)

Symbol for clearance in the axial direction  
(G0 for all SBK variations)With QZ Lubricator  
(no symbol if the model is without a QZ Lubricator)(\*1) See **A15-12**.

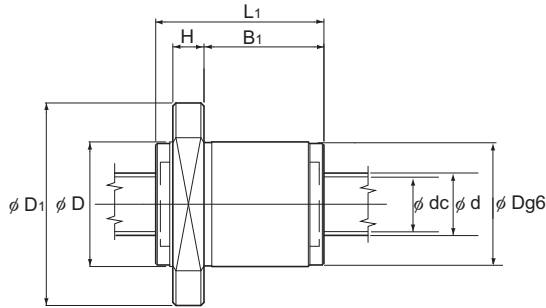

Unit: mm

	Nut dimensions									Screw shaft inertial moment/mm kg·cm <sup>2</sup> /mm	Nut mass kg	Shaft mass kg/m	Maximum permissible rotation speed min <sup>-1</sup>
	Outer diameter D	Flange diameter D <sub>1</sub>	Overall length L <sub>1</sub>	H	B <sub>1</sub>	PCD	d <sub>1</sub>	T <sub>w</sub>	Greasing hole A				
	38	62	54	10	38.5	49	5.5	39	M6	3.9 × 10 <sup>-4</sup>	0.41	1.27	5000
	33	54	45	10	29.5	43	4.5	38	M6	5.05 × 10 <sup>-4</sup>	0.25	1.46	
	40	65	45	10	29.5	53	5.5	49	M6	1.23 × 10 <sup>-3</sup>	0.37	2.18	
	40	65	54	10	38.5	53	5.5	49	M6	1.23 × 10 <sup>-3</sup>	0.43	2.32	
	40	65	71	10	55.5	53	5.5	49	M6	1.23 × 10 <sup>-3</sup>	0.55	2.36	
	47	74	57	12	38	60	6.6	56	M6	3.01 × 10 <sup>-3</sup>	0.59	3.58	
	47	74	68	12	49	60	6.6	56	M6	3.01 × 10 <sup>-3</sup>	0.69	3.63	3900
	58	92	82	15	58	74	9	68	M6	8.08 × 10 <sup>-3</sup>	1.23	5.82	
	58	92	118	15	94	74	9	68	M6	8.08 × 10 <sup>-3</sup>	1.70	5.99	

Note) The rigidity values in the table represent the spring constants obtained from the load and the elastic deformation when providing a preload 10% of the basic dynamic load rating (Ca) and applying an axial load three times greater than the preload.

These values do not include the rigidity of the components related to mounting the ball screw nut. Therefore, it is normally appropriate to regard roughly 80% of the value in the table as the actual value.

If the applied preload (Fa<sub>0</sub>) is not 0.1 Ca, the rigidity value (K<sub>s</sub>) is obtained from the following equation.

$$K_s = K \left( \frac{Fa_0}{0.1Ca} \right)^{\frac{1}{3}}$$

K: Rigidity value in the dimensional table.

# Model SBK

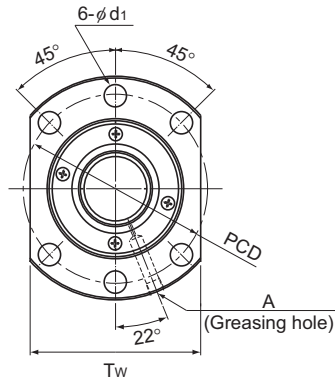

Model No.	Screw shaft outer diameter d	Lead Ph	Ball center-to-center diameter dp	Thread minor diameter dc	No. of loaded circuits Rows × turns	Basic load rating		Rigidity K N/μm
						Ca kN	C <sub>a</sub> kN	
SBK 3620-7.6	36	20	37.75	30.4	1×3.8	48.5	85	870
SBK 3636-5.6	36	36	37.75	31.4	1×2.8	36.6	64.7	460
SBK 4020-7.6	40	20	42	34.1	1×3.8	59.7	112.7	970
SBK 4030-7.6	40	30	42	34.1	1×3.8	59.2	107.5	970
SBK 4040-5.6	40	40	42	34.9	1×2.8	44.8	80.3	520
SBK 5020-7.6	50	20	52	44.1	1×3.8	66.8	141.9	1170
SBK 5030-7.6	50	30	52	44.1	1×3.8	66.5	135	1170
SBK 5036-7.6	50	36	52	44.1	1×3.8	65.9	135	1170
SBK 5050-5.6	50	50	52	44.9	1×2.8	50.3	102.4	630
SBK 5520-7.6	55	20	57	49.1	1×3.8	69.8	156.4	1250
SBK 5530-7.6	55	30	57	49.1	1×3.8	69.2	147	1250
SBK 5536-7.6	55	36	57	49.1	1×3.8	69.1	148.7	1260

Note) With model SBK, the raising of both ends of the thread groove is not available. When designing your system this way, contact THK.

Axial Clearance

Unit: mm

Clearance symbol	G0
Axial Clearance	0 or less

## Model number coding

**SBK3620-7.6 RR G0 +1500L C5**

Model number

Seal symbol (\*1)

Overall screw shaft length (in mm)

Accuracy symbol (\*2)

Symbol for clearance in the axial direction (G0 for all SBK variations)

(\*1) See **A15-352**. (\*2) See **A15-12**.

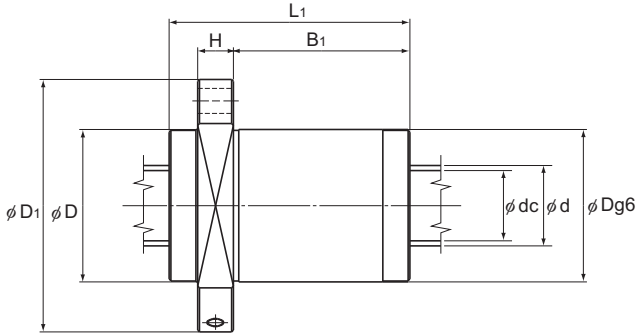

Unit: mm

	Nut dimensions									Screw shaft inertial moment/mm <sup>2</sup>	Nut mass	Shaft mass
	Outer diameter	Flange diameter	Overall length	H	B <sub>1</sub>	PCD	d <sub>i</sub>	T <sub>w</sub>	Greasing hole			
	D	D <sub>1</sub>	L <sub>1</sub>	H	B <sub>1</sub>	PCD	d <sub>i</sub>	T <sub>w</sub>	A	kg·cm <sup>2</sup> /mm	kg	kg/m
	73	114	110	18	81	93	11	86	PT 1/8	1.29 × 10 <sup>-2</sup>	3.4	5.0
	73	114	134	18	105	93	11	86	PT 1/8	1.29 × 10 <sup>-2</sup>	3.37	7.43
	80	136	110	20	79	112	14	103	PT 1/8	1.97 × 10 <sup>-2</sup>	4.5	5.7
	80	136	148	20	117	112	14	103	PT 1/8	1.97 × 10 <sup>-2</sup>	5.6	7.0
	80	136	146	20	115	112	14	103	PT 1/8	1.97 × 10 <sup>-2</sup>	4.74	9.16
	90	146	110	22	77	122	14	110	PT 1/8	4.82 × 10 <sup>-2</sup>	5.3	10.2
	90	146	149	22	116	122	14	110	PT 1/8	4.82 × 10 <sup>-2</sup>	6.6	11.9
	90	146	172	22	139	122	14	110	PT 1/8	4.82 × 10 <sup>-2</sup>	7.4	12.5
	90	146	175	22	142	122	14	110	PT 1/8	4.82 × 10 <sup>-2</sup>	6.46	14.72
	96	152	110	22	77	128	14	114	PT 1/8	7.05 × 10 <sup>-2</sup>	5.7	13.0
	96	152	149	22	116	128	14	114	PT 1/8	7.05 × 10 <sup>-2</sup>	7.2	14.8
	96	152	172	22	139	128	14	114	PT 1/8	7.05 × 10 <sup>-2</sup>	8.1	15.5

Note) The rigidity values in the table represent the spring constants obtained from the load and the elastic deformation when providing a preload 10% of the basic dynamic load rating (Ca) and applying an axial load three times greater than the preload.

These values do not include the rigidity of the components related to mounting the ball screw nut. Therefore, it is normally appropriate to regard roughly 80% of the value in the table as the actual value.

If the applied preload (Fa<sub>0</sub>) is not 0.1 Ca, the rigidity value (K<sub>N</sub>) is obtained from the following equation.

$$K_N = K \left( \frac{F_{a0}}{0.1 C_a} \right)^{\frac{1}{3}}$$

K: Rigidity value in the dimensional table.



# Model SDA

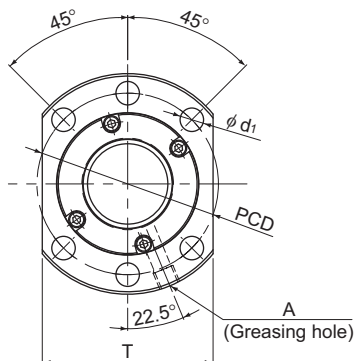

Model No.	Screw shaft outer diameter d	Lead Ph	Ball center-to-center diameter dp	Screw shaft Thread minor diameter dc	No. of loaded circuits Rows x turns	Basic load rating		Rigidity K N/μm
						Ca kN	C <sub>0a</sub> kN	
★ ☆ SDA 1510-2.8	15	10	15.5	13.1	1×2.8	5.5	7.8	144
SDA 1520-3.6	15	20	15.5	13.1	2×1.8	6.4	10.3	183
SDA 1530-3.6	15	30	15.5	13.1	2×1.8	6.1	8.9	190
SDA 1610-2.8	16	10	16.5	14.1	1×2.8	5.6	8.2	150
SDA 1616-2.8	16	16	16.5	14.1	1×2.8	5.5	8.4	152
☆ SDA 2020-2.8	20	20	20.75	17.1	1×2.8	10.9	17.6	207
SDA 2030-1.8	20	30	20.75	17.1	1×1.8	7.0	11.5	135
☆ SDA 2040-1.8	20	40	20.75	17.1	1×1.8	6.8	9.9	141
☆ SDA 2060-1.6	20	60	20.75	17.1	2×0.8	5.4	9.7	128
SDA 2520-2.8	25	20	25.75	22.1	1×2.8	12.1	21.6	245
SDA 2525-2.8	25	25	25.75	22.1	1×2.8	12.0	22.0	246
SDA 2530-1.8	25	30	25.75	22.1	1×1.8	8.2	14.5	164
SDA 2550-1.8	25	50	25.75	22.1	1×1.8	7.6	12.6	170

Note) If desiring to shape both ends of the screw shaft to have a larger diameter than the outer diameter of the screw shaft, contact THK.

★: The outer diameter dimension complies with "lead: 5 or less" of DIN standard 69051.

☆: Labyrinth seal is standard (other models come standard without labyrinth seal).

Axial Clearance

Unit: mm

Clearance symbol	G0
Axial Clearance	0 or less

## Model number coding

**SDA2520-2.8 QZ RR G0 +830L C3**

Model Number

Accuracy symbol (\*2)

Overall screw shaft length (in mm)

With QZ Lubricator

(no symbol if the model is without QZ Lubricator)

Symbol for clearance in the axial direction (G0 for all SDA variations)

Seal symbol(\*1) (RR: labyrinth seal on both sides; WW: wiper ring on both sides)

(\*1) See **A15-352**. (\*2) See **A15-12**.

## Precision, Caged Ball Screw

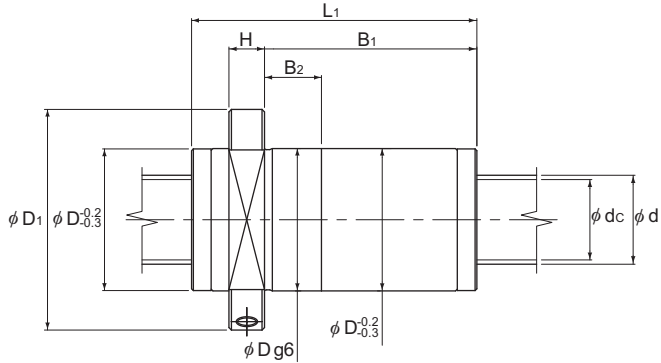

Unit: mm

	Nut dimensions										Screw shaft inertial moment/mm kg·cm <sup>2</sup> /mm	Nut mass kg	Shaft mass kg/m	Maximum permissible rotation speed min <sup>-1</sup>
	Outer diameter D	Flange diameter D <sub>1</sub>	Overall length L <sub>1</sub>	H	B <sub>1</sub>	B <sub>2</sub>	PCD	d <sub>1</sub>	T	Greasing hole A				
	28	48	35.3	10	16.8	10	38	5.5	40	M6	$3.9 \times 10^{-4}$	0.16	1.32	5000
	28	48	44.6		25.1	10	38	5.5	40		$3.9 \times 10^{-4}$	0.18	1.35	
	28	48	64.9		43.9	10	38	5.5	40		$3.9 \times 10^{-4}$	0.24	1.33	
	28	48	35.4		16.9	12.9	38	5.5	40		$5.05 \times 10^{-4}$	0.15	1.50	
	28	48	51.9		33.4	10	38	5.5	40		$5.05 \times 10^{-4}$	0.20	1.49	
	36	58	65.8		45.3	12	47	6.6	44		$1.23 \times 10^{-3}$	0.35	2.39	
	36	58	65.2		43.7	12	47	6.6	44		$1.23 \times 10^{-3}$	0.34	2.40	
	36	58	85.5		61	12	47	6.6	44		$1.23 \times 10^{-3}$	0.43	2.37	
	36	58	66.3		40.3	12	47	6.6	44		$1.23 \times 10^{-3}$	0.31	2.40	
	40	62	66.4		45.9	16	51	6.6	48		$3.01 \times 10^{-3}$	0.39	3.75	
	40	62	80.2		59.7	16	51	6.6	48		$3.01 \times 10^{-3}$	0.46	3.76	
	40	62	65.1		44.1	16	51	6.6	48		$3.01 \times 10^{-3}$	0.37	3.77	
	40	62	105.4		80.4	16	51	6.6	48		$3.01 \times 10^{-3}$	0.58	3.79	

Note) The rigidity values (K) in the table represent spring constants each obtained from the load and the elastic deformation under an axial load representing 30% of the basic dynamic load rating (Ca). These values do not include the rigidity of the components related to mounting the ball screw nut. Therefore, it is normally appropriate to regard roughly 80% of the rigidity value (K) in the table as the actual value. If the axial load (Fa) is not 0.3 Ca, the rigidity value (K<sub>v</sub>) is obtained from the following equation.

$$K_v = K \left( \frac{F_a}{0.3C_a} \right)^3$$

K: Rigidity value in the dimensional table.

# Model HBN

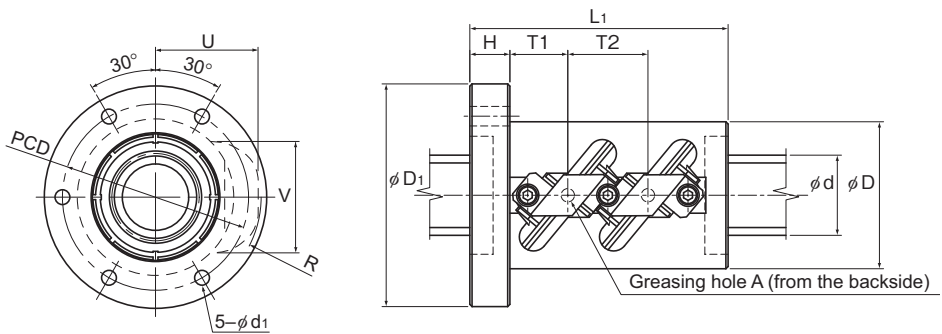

Models HBN3210 to 3612

Model No.	Screw shaft outer diameter d	Lead Ph	Ball center-to-center diameter dp	Thread minor diameter dc	No. of loaded circuits Rows × turns	Basic load rating		Permissible load* F <sub>P</sub> kN	Rigidity K N/μm
						Ca kN	C <sub>0a</sub> kN		
HBN 3210-5	32	10	34	26	2×2.5	102.9	191.3	31.9	1077
HBN 3610-5	36	10	38	30	2×2.5	108.2	220.4	33.5	1176
HBN 3612-5	36	12	38.4	29	2×2.5	141.1	267.7	43.7	1207
HBN 4010-7.5	40	10	42	34	3×2.5	162.6	336	50.4	1910
HBN 4012-7.5	40	12	42.4	33	3×2.5	212.4	441.6	65.8	1922
HBN 5010-7.5	50	10	52	44	3×2.5	179.1	462.7	55.5	2279
HBN 5012-7.5	50	12	52.4	43	3×2.5	235.7	572.2	73.1	2345
HBN 5016-7.5	50	16	53	39.6	3×2.5	379.6	820.9	117.7	2392
HBN 6316-7.5	63	16	66	52.6	3×2.5	427.1	1043.8	132.4	2898
HBN 6316-10.5	63	16	66	52.6	3×3.5	577.1	1461.3	178.9	4029
HBN 6320-7.5	63	20	66.5	49.6	3×2.5	578.8	1283.1	179.4	3030

Note) The permissible load F<sub>P</sub>\* indicates the maxim axial load that the Ball Screw can receive.

This model is capable of achieving a longer service life than the conventional Ball Screw under a high load.

Axial Clearance

Unit: mm

Clearance symbol	G2
Axial Clearance	0 to 0.02

## Model number coding

**HBN3210-5 RR G2 +1200L C7**

Model number Seal symbol (\*1)

Accuracy symbol (\*2)

Overall screw shaft length (in mm)

Symbol for clearance in the axial direction

(For the axial clearance, this model has clearance G2 as standard.)

Other clearance is also available at your request. Contact THK for details.)

(\*1) See **A15-352**. (\*2) See **A15-12**.

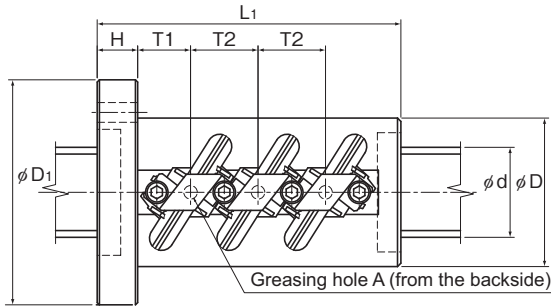

Models HBN4010 to 6320

Unit: mm

	Nut dimensions											Screw shaft inertial moment/mm <sup>2</sup> kg·cm <sup>2</sup> /mm	Nut mass kg	Shaft mass kg/m	
	Outer diameter D	Flange diameter D <sub>1</sub>	Overall length L <sub>1</sub>	H	PCD	d <sub>1</sub>	T1	T2	U <sub>MAX</sub>	V <sub>MAX</sub>	R <sub>MAX</sub>				Greasing hole A
	58	85	98	15	71	6.6	22	30	43	46	43.5	M6	8.08 × 10 <sup>-3</sup>	1.8	5.26
	62	89	98	15	75	6.6	22	30	45	50	46	M6	1.29 × 10 <sup>-2</sup>	1.9	6.79
	66	100	116	18	82	9	26	36	49	52.5	50	M6	1.29 × 10 <sup>-2</sup>	2.8	6.55
	66	100	135	18	82	9	23.5	30	46.5	54	48	M6	1.97 × 10 <sup>-2</sup>	2.9	8.52
	70	104	152	18	86	9	26	36	51	56	52	M6	1.97 × 10 <sup>-2</sup>	3.7	5.24
	78	112	135	18	94	9	23.5	30	52	63.5	54.5	M6	4.82 × 10 <sup>-2</sup>	3.7	13.7
	80	114	152	18	96	9	26	36	56	66	58.5	M6	4.82 × 10 <sup>-2</sup>	4.4	13.34
	95	135	211	28	113	9	37.5	48	64.5	69.6	65.2	PT 1/8	4.82 × 10 <sup>-2</sup>	10.0	12.1
	105	139	211	28	122	9	37.5	48	70.5	82	72.5	PT 1/8	1.21 × 10 <sup>-1</sup>	10.6	20.2
	105	139	259	28	122	9	53.5	64	70.5	82	73	PT 1/8	1.21 × 10 <sup>-1</sup>	17.4	20.2
	117	157	252	32	137	11	44	60	79	86.5	80	PT 1/8	1.21 × 10 <sup>-1</sup>	17.2	19.13

Note) The rigidity values in the table represent the spring constants obtained from the load and the elastic deformation when providing an axial load, 30% of the basic dynamic load rating (Ca).

These values do not include the rigidity of the components related to mounting the ball screw nut. Therefore, it is normally appropriate to regard roughly 80% of the value in the table as the actual value.

If the axial load (Fa) is not 0.3 Ca, the rigidity value (K<sub>n</sub>) is obtained from the following equation.

$$K_n = K \left( \frac{Fa}{0.3Ca} \right)^{\frac{1}{3}}$$

K: Rigidity value in the dimensional table.

## Model SBKH

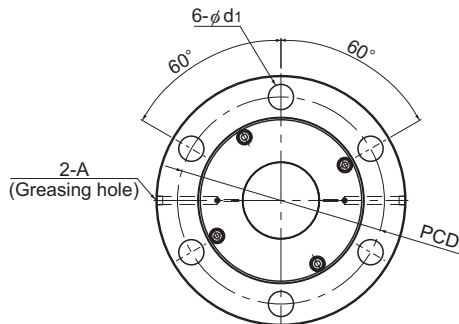

Model No.	Screw shaft outer diameter d	Lead Ph	Ball center-to-center diameter dp	Screw shaft Thread minor diameter dc	No. of loaded circuits Rows X turns	Basic load rating		Permissible load* Fp kN	Rigidity K N/μm
						Ca kN	C <sub>0a</sub> kN		
SBKH 6332-3.8	63	32	66.5	49.8	1×3.8	304	631	88	1435
SBKH 6340-7.6	63	40	66.0	52.6	2×3.8	413	967	135	2723
SBKH 8050-7.6	80	50	84.0	63.6	2×3.8	777	1788	250	3402
SBKH 8060-7.6	80	60	84.0	63.6	2×3.8	780	1824	255	3452
SBKH 10050-7.6	100	50	104.0	83.6	2×3.8	876	2401	336	4098
SBKH 10060-7.6	100	60	104.0	83.6	2×3.8	880	2294	321	4149
SBKH 12060-7.6	120	60	124.0	103.6	2×3.8	962	2941	411	4809

Note) The permissible load  $F_p^*$  indicates the maximum axial load that the Ball Screw can receive.  
If desiring both ends of the screw shaft to be larger than the screw shaft diameter, contact THK.

Axial Clearance

Unit: mm

Clearance symbol	G1	G2	G3
Axial Clearance	0 to 0.01	0 to 0.02	0 to 0.05

### Model number coding

**SBKH8050-7.6 RR G2 +1200L C7**

Model Number

Accuracy symbol (\*2)

Overall screw shaft length (in mm)

Axial clearance symbol  
(clearance in the axial direction must be: G1, G2 or G3.  
Clearance G0 and GT are not supported.)

Seal symbol(\*1)

(RR: labyrinth seal on both sides)

(\*1) See **A15-352**. (\*2) See **A15-12**.

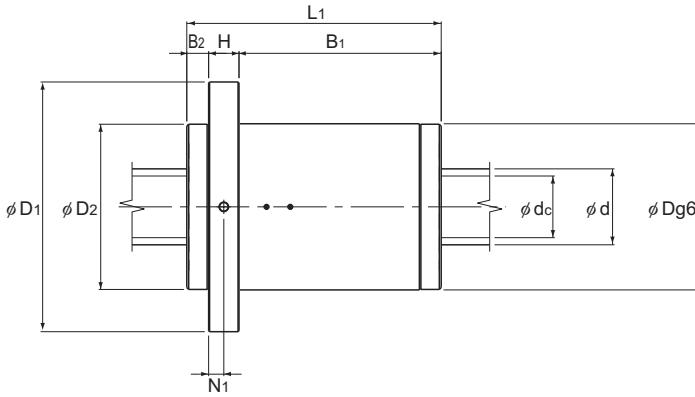

Unit: mm

	Nut dimensions											Screw shaft inertial moment/mm kg·cm <sup>2</sup> /mm	Nut mass kg	Shaft mass* <sup>1</sup> kg/m
	Outer diameter D	Flange diameter D <sub>1</sub>	Cap diameter D <sub>2</sub>	Overall length L <sub>1</sub>	H	B <sub>1</sub>	B <sub>2</sub>	PCD	d <sub>i</sub>	N <sub>1</sub>	Greasing hole A			
	140	205	(140)	190	28	143	(19)	173	22	14	PT1/8	1.21 × 10 <sup>-1</sup>	17.2	21.0
	127	191	(127)	209	30	163	(16)	159	22	15	PT1/8	1.21 × 10 <sup>-1</sup>	15.5	21.0
	175	253	(175)	268	32	213	(23)	214	26	16	PT1/8	3.16 × 10 <sup>-1</sup>	36.9	31.3
	175	253	(175)	306	40	243	(23)	214	26	20	PT1/8	3.16 × 10 <sup>-1</sup>	43.5	32.5
	195	273	(195)	269	40	206	(23)	234	26	20	PT1/8	7.71 × 10 <sup>-1</sup>	44.5	51.3
	195	273	(195)	307	40	244	(23)	234	26	20	PT1/8	7.71 × 10 <sup>-1</sup>	50.5	52.9
	210	288	(210)	308	45	240	(23)	249	26	22.5	PT1/8	1.60	53.7	78.1

Note1) There will be no dimensional change after the seal is attached.

Note2) The rigidity values (K) in the table represent spring constants each obtained from the load and the elastic deformation under an axial load representing 30% of the basic dynamic load rating (Ca).

These values do not include the rigidity of the components related to mounting the ball screw nut. Therefore, it is normally appropriate to regard roughly 80% of the rigidity value (K) in the table as the actual value.

If the axial load (Fa) is not 0.3 Ca, the rigidity value (K<sub>N</sub>) is obtained from the following equation.

$$K_N = K \left( \frac{F_a}{0.3C_a} \right)^3$$

K: Rigidity value in the dimensional table.



SKSSWEDEN