

DIN Standard compliant Ball Screw (DIN69051)

Models EBA, EBB, EBC, EPA, EPB and EPC

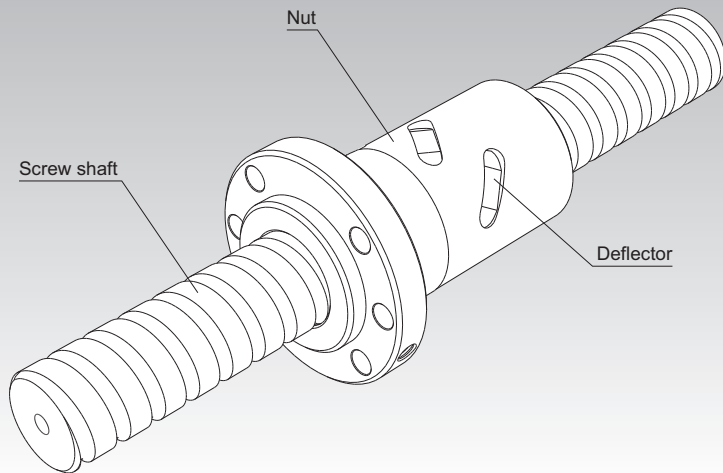

Fig.1 DIN Standard (DIN69051) Compliant Precision Ball Screw

Point of Selection **A15-8**

Options **A15-352**

Model No. **A15-369**

Precautions on Use **A15-374**

Accessories for Lubrication **A24-1**

Mounting Procedure and Maintenance **B15-104**

Lead Angle Accuracy **A15-11**

Accuracy of the Mounting Surface **A15-14**

Axial Clearance **A15-19**

Maximum Length of the Screw Shaft **A15-24**

DN Value **A15-33**

Support Unit **A15-316**

Recommended Shapes of Shaft Ends **A15-324**

Dimensions of Each Model with an Option Attached **A15-360**

Structure and Features

In the DIN standard compliant Ball Screw, balls under a load roll in the raceway cut between the screw shaft and the nut while receiving the axial load, travel along the groove of a deflector embedded inside the nut to the adjacent raceway, and then circulate back to the loaded area. Thus, the balls perform infinite rolling motion.

Two types of nuts are available: model EB of oversized-ball preload type or non-preloaded type, and model EP of offset preloaded type.

[Compact]

This Ball Screw is compactly built. Because of an internal circulation system using deflectors, the outer diameter of the nut is 70 to 80% of the conventional double nut and the overall nut length is only 60 to 80% of the return pipe nut.

[Compliant with a DIN standard]

The nut flange shape, mounting holes and rated load are compliant with DIN69051.

Types and Features

Models EPA/EBA

[Flange shape: round-flange type]

Specification Table⇒ [A15-94](#)/[A15-88](#)

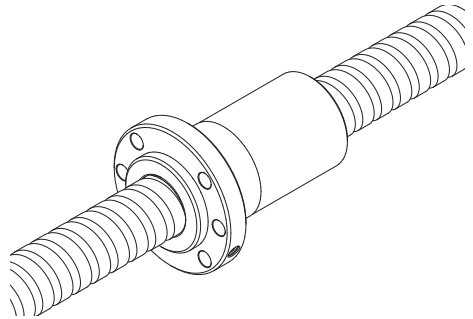

Models EPB/EBB

[Flange shape: type with two cut faces]

Specification Table⇒ [A15-96](#)/[A15-90](#)

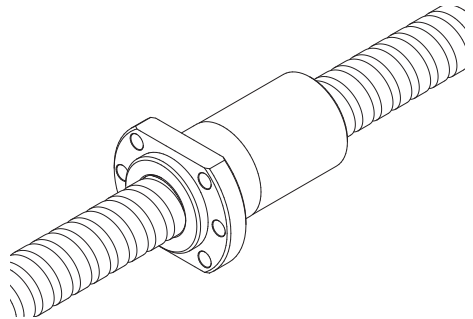

Models EPC/EBC

[Flange shape: type with one cut face]

Specification Table⇒ [A15-98](#)/[A15-92](#)

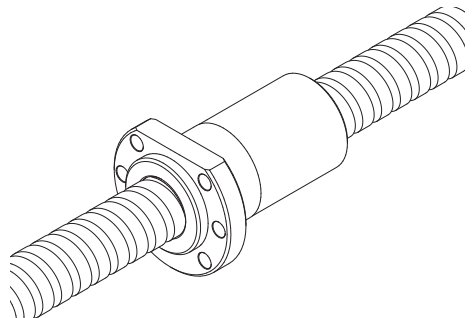

Accuracy Standards

The accuracy of DIN standard compliant Ball Screw is controlled in accordance with ISO standard (ISO3408-3) and JIS standard (JIS B1192-1997). C, Cp and Ct grades are defined for this Ball Screw series.

Grade C (see page **A15-11**)

Grade Cp, Ct (see ISO 3408-3)

Grade	0	1	2	3	5	7
C	○	○	○	○	○	○
Cp	—	—	—	○	○	—
Ct	—	—	—	○	○	○

Model EBA (Dimensional Table of Model EBA Oversized-ball preload type or non-preloaded type)

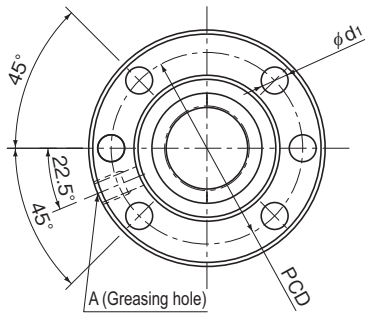

Hole type 1
(Model EBA1605 to 3210)

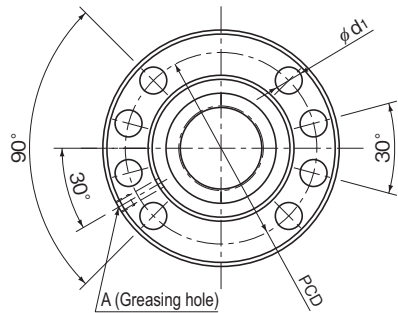

Hole type 2
(Model EBA4005 to 6320)

Model No.	Screw shaft outer diameter d	Lead ℓ	Ball diameter Da	Ball center-to-center diameter dp	Thread minor diameter ds	No. of loaded circuits Rows x turns	Basic load rating		Rigidity K N/μm
							Ca*	Ca	
EBA 1605-4	16	5	3.175	16.75	13.1	4×1	11.9	17.4	210
EBA 2005-3	20	5	3.175	20.75	17.1	3×1	10.6	17.3	200
EBA 2505-3	25	5	3.175	25.75	22.1	3×1	12.1	22.6	250
EBA 2510-3	25	10	3.969	26	21.6	3×1	15.9	27	250
EBA 2510-4	25	10	3.969	26	21.6	4×1	20.9	37.6	330
EBA 3205-3	32	5	3.175	32.75	29.2	3×1	13.9	30.2	300
EBA 3205-4	32	5	3.175	32.75	29.2	4×1	17.8	40.3	400
EBA 3205-6	32	5	3.175	32.75	29.2	6×1	25.1	60.4	600
EBA 3210-3	32	10	6.35	33.75	26.4	3×1	32.1	52.2	300
EBA 3210-4	32	10	6.35	33.75	26.4	4×1	41.3	69.7	390
EBA 4005-6	40	5	3.175	40.75	37.1	6×1	26.6	77.5	716
EBA 4010-3	40	10	6.35	41.75	34.4	3×1	37.3	69.3	380
EBA 4010-4	40	10	6.35	41.75	34.4	4×1	47.6	92.4	500
EBA 4020-3	40	20	6.35	41.75	34.7	3×1	36.8	69.3	750
EBA 5010-4	50	10	6.35	51.75	44.4	4×1	54.3	120.5	610
EBA 5020-3	50	20	7.938	52.25	43.6	3×1	55.3	108.8	470
EBA 6310-6	63	10	6.35	64.75	57.7	6×1	87.9	242.1	1140
EBA 6320-3	63	20	9.525	65.7	56.0	3×1	104.4	229.3	1470

Note) ★ Basic Dynamic Load Rating(Ca) of the accuracy C7 and Ct7 is 0.9Ca.

Model number coding

EB A 20 05 -6 QZ RR G0 +650L C3

Shaft diameter: A
 Number of turns: 20
 Lead: 05
 Clearance symbol: -6
 Seal symbol (RR : Labyrinth seal, WW : Wiper ring.): QZ
 Accuracy symbol: RR
 Ball screw shaft length (mm): G0
 With QZ Lubricator (no symbol without QZ Lubricator): +650L
 Flange shape: C3
 Nut type: oversized-ball preload type or non-preloaded type

DIN Standard compliant Ball Screw (DIN69051)

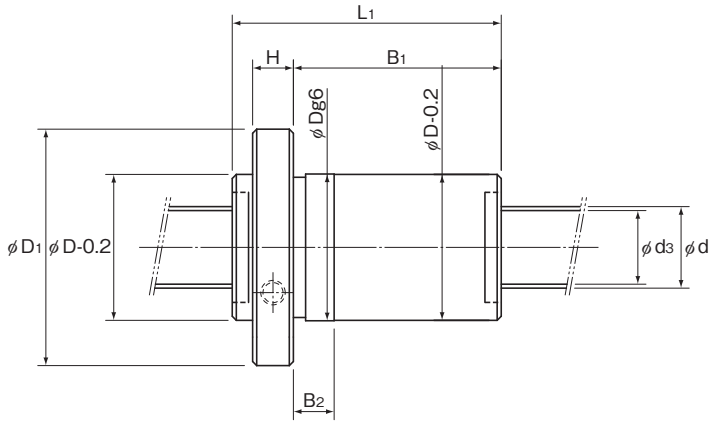

Unit: mm

Nut dimensions											
Outer diameter	Flange diameter	Overall length					Hole type	PCD	d ₁	Tw	Greasing hole
D	D ₁	L ₁	H	B ₁	B ₂						A
28	48	55	10	40	12		1	38	5.5	20	M6×1
36	58	50	10	35	12		1	47	6.6	22	M6×1
40	62	50	10	35	12		1	51	6.6	24	M6×1
40	62	80	10	65	18		1	51	6.6	24	M6×1
40	62	85	10	70	18		1	51	6.6	24	M6×1
50	80	52	12	35	12		1	65	9	31	M6×1
50	80	57	12	40	12		1	65	9	31	M6×1
50	80	67	12	50	12		1	65	9	31	M6×1
50	80	82	12	65	18		1	65	9	31	M6×1
50	80	94	12	77	18		1	65	9	31	M6×1
63	93	70	14	51	12		2	78	9	35	M8×1
63	93	84	14	65	18		2	78	9	35	M8×1
63	93	94	14	75	18		2	78	9	35	M8×1
63	93	129	14	105	25		2	78	9	35	M8×1
75	110	96	16	75	18		2	93	11	42.5	M8×1
75	110	134	16	108	27		2	93	11	42.5	M8×1
90	125	119	18	96	18		2	108	11	47.5	M8×1
95	135	136	18	108	27		2	115	13.5	50	M8×1

Note) The rigidity values in the table represent spring constants each obtained from the load and the Elastic Deformation finish when providing an axial load 24% of the basic dynamic load rating (Ca).

These values do not include the rigidity of the components related to mounting the nut. Therefore, it is normally appropriate to regard roughly 80% of the value in the table as the actual value.

If the axial load (Fa) is not 0.24 Ca, the rigidity value (K_N) is obtained from the following equation.

$$K_N = K \left(\frac{Fa}{0.24Ca} \right)^{\frac{1}{3}}$$

K: Rigidity value in the dimensional table.

Model EBB (Dimensional Table of Model EBB Oversized-ball preload type or non-preloaded type)

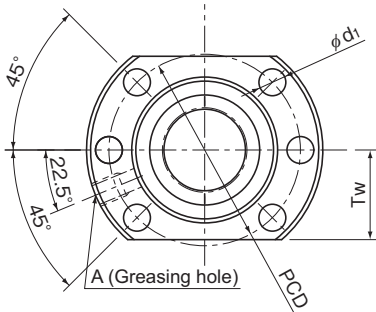

Hole type 1
(Model EBB1605 to 3210)

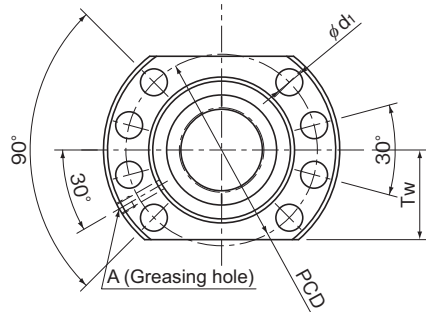

Hole type 2
(Model EBB4005 to 6320)

Model No.	Screw shaft outer diameter d	Lead l	Ball diameter Da	Ball center-to-center diameter dp	Thread minor diameter ds	No. of loaded circuits Rows x turns	Basic load rating		Rigidity K N/μm
							Ca*	Ca	
EBB 1605-4	16	5	3.175	16.75	13.1	4×1	11.9	17.4	210
EBB 2005-3	20	5	3.175	20.75	17.1	3×1	10.6	17.3	200
EBB 2505-3	25	5	3.175	25.75	22.1	3×1	12.1	22.6	250
EBB 2510-3	25	10	3.969	26	21.6	3×1	15.9	27	250
EBB 2510-4	25	10	3.969	26	21.6	4×1	20.9	37.6	330
EBB 3205-3	32	5	3.175	32.75	29.2	3×1	13.9	30.2	300
EBB 3205-4	32	5	3.175	32.75	29.2	4×1	17.8	40.3	400
EBB 3205-6	32	5	3.175	32.75	29.2	6×1	25.1	60.4	600
EBB 3210-3	32	10	6.35	33.75	26.4	3×1	32.1	52.2	300
EBB 3210-4	32	10	6.35	33.75	26.4	4×1	41.3	69.7	390
EBB 4005-6	40	5	3.175	40.75	37.1	6×1	26.6	77.5	716
EBB 4010-3	40	10	6.35	41.75	34.4	3×1	37.3	69.3	380
EBB 4010-4	40	10	6.35	41.75	34.4	4×1	47.6	92.4	500
EBB 4020-3	40	20	6.35	41.75	34.7	3×1	36.8	69.3	750
EBB 5010-4	50	10	6.35	51.75	44.4	4×1	54.3	120.5	610
EBB 5020-3	50	20	7.938	52.25	43.6	3×1	55.3	108.8	470
EBB 6310-6	63	10	6.35	64.75	57.7	6×1	87.9	242.1	1140
EBB 6320-3	63	20	9.525	65.7	56.0	3×1	104.4	229.3	1470

Note) ★ Basic Dynamic Load Rating(Ca) of the accuracy C7 and Ct7 is 0.9Ca.

Model number coding

EB B 20 05 -6 QZ RR G0 +650L C3

EB: Flange shape (A: round; B: double chamfered; C: single chamfered)
 B: Shaft diameter
 20: Lead
 05: Number of turns
 -6: Clearance symbol
 QZ: Seal symbol (RR: Labyrinth seal, WW: Wiper ring.)
 RR: With QZ Lubricator (no symbol without QZ Lubricator)
 G0: Ball screw shaft length (mm)
 +650L: Accuracy symbol
 C3: Nut type: oversized-ball preload type or non-preloaded type

DIN Standard compliant Ball Screw (DIN69051)

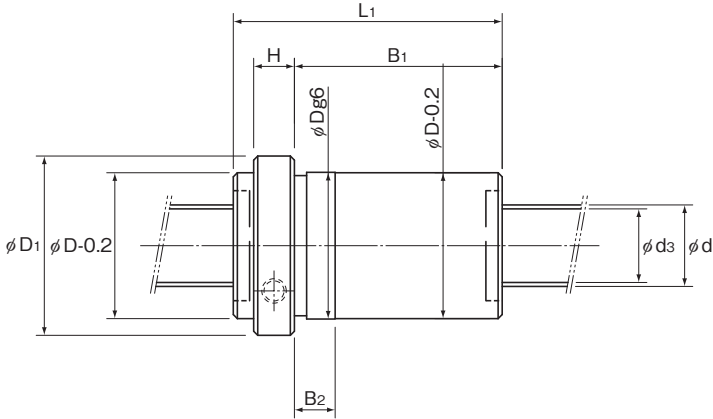

Unit: mm

Nut dimensions											
Outer diameter	Flange diameter	Overall length					Hole type	PCD	d ₁	Tw	Greasing hole
D	D ₁	L ₁	H	B ₁	B ₂						A
28	48	55	10	40	12		1	38	5.5	20	M6×1
36	58	50	10	35	12		1	47	6.6	22	M6×1
40	62	50	10	35	12		1	51	6.6	24	M6×1
40	62	80	10	65	18		1	51	6.6	24	M6×1
40	62	85	10	70	18		1	51	6.6	24	M6×1
50	80	52	12	35	12		1	65	9	31	M6×1
50	80	57	12	40	12		1	65	9	31	M6×1
50	80	67	12	50	12		1	65	9	31	M6×1
50	80	82	12	65	18		1	65	9	31	M6×1
50	80	94	12	77	18		1	65	9	31	M6×1
63	93	70	14	51	12		2	78	9	35	M8×1
63	93	84	14	65	18		2	78	9	35	M8×1
63	93	94	14	75	18		2	78	9	35	M8×1
63	93	129	14	105	25		2	78	9	35	M8×1
75	110	96	16	75	18		2	93	11	42.5	M8×1
75	110	134	16	108	27		2	93	11	42.5	M8×1
90	125	119	18	96	18		2	108	11	47.5	M8×1
95	135	136	18	108	27		2	115	13.5	50	M8×1

Note) The rigidity values in the table represent spring constants each obtained from the load and the Elastic Deformation finish when providing an axial load 24% of the basic dynamic load rating (Ca).

These values do not include the rigidity of the components related to mounting the nut. Therefore, it is normally appropriate to regard roughly 80% of the value in the table as the actual value.

If the axial load (Fa) is not 0.24 Ca, the rigidity value (K_N) is obtained from the following equation.

$$K_N = K \left(\frac{F_a}{0.24 C_a} \right)^{\frac{1}{3}}$$

K: Rigidity value in the dimensional table.

Model EBC (Dimensional Table of Model EBC Oversized-ball preload type or non-preloaded type)

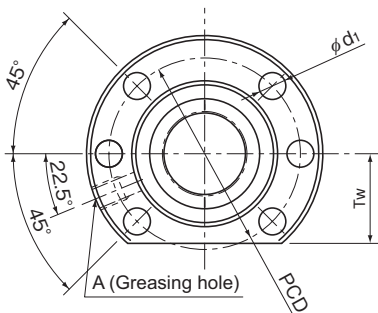

Hole type 1
(Model EBC1605 to 3210)

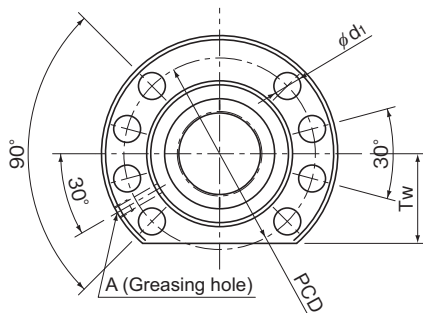

Hole type 2
(Model EBC4005 to 6320)

Model No.	Screw shaft outer diameter d	Lead ℓ	Ball diameter Da	Ball center-to-center diameter dp	Thread minor diameter d _s	No. of loaded circuits Rows x turns	Basic load rating		Rigidity K N/μm
							Ca*	C _a	
							kN	kN	
EBC 1605-4	16	5	3.175	16.75	13.1	4×1	11.9	17.4	210
EBC 2005-3	20	5	3.175	20.75	17.1	3×1	10.6	17.3	200
EBC 2505-3	25	5	3.175	25.75	22.1	3×1	12.1	22.6	250
EBC 2510-3	25	10	3.969	26	21.6	3×1	15.9	27	250
EBC 2510-4	25	10	3.969	26	21.6	4×1	20.9	37.6	330
EBC 3205-3	32	5	3.175	32.75	29.2	3×1	13.9	30.2	300
EBC 3205-4	32	5	3.175	32.75	29.2	4×1	17.8	40.3	400
EBC 3205-6	32	5	3.175	32.75	29.2	6×1	25.1	60.4	600
EBC 3210-3	32	10	6.35	33.75	26.4	3×1	32.1	52.2	300
EBC 3210-4	32	10	6.35	33.75	26.4	4×1	41.3	69.7	390
EBC 4005-6	40	5	3.175	40.75	37.1	6×1	26.6	77.5	716
EBC 4010-3	40	10	6.35	41.75	34.4	3×1	37.3	69.3	380
EBC 4010-4	40	10	6.35	41.75	34.4	4×1	47.6	92.4	500
EBC 4020-3	40	20	6.35	41.75	34.7	3×1	36.8	69.3	750
EBC 5010-4	50	10	6.35	51.75	44.4	4×1	54.3	120.5	610
EBC 5020-3	50	20	7.938	52.25	43.6	3×1	55.3	108.8	470
EBC 6310-6	63	10	6.35	64.75	57.7	6×1	87.9	242.1	1140
EBC 6320-3	63	20	9.525	65.7	56.0	3×1	104.4	229.3	1470

Note) ★ Basic Dynamic Load Rating(Ca) of the accuracy C7 and Ct7 is 0.9Ca.

Model number coding

EB C 20 05 -6 QZ RR G0 +650L C3

Shaft diameter Number of turns Clearance symbol Accuracy symbol

Lead

Ball screw shaft length (mm)

Seal symbol (RR : Labyrinth seal, WW : Wiper ring.)

With QZ Lubricator (no symbol without QZ Lubricator)

Flange shape: A: round; B: double chamfered; C: single chamfered

Nut type: oversized-ball preload type or non-preloaded type

DIN Standard compliant Ball Screw (DIN69051)

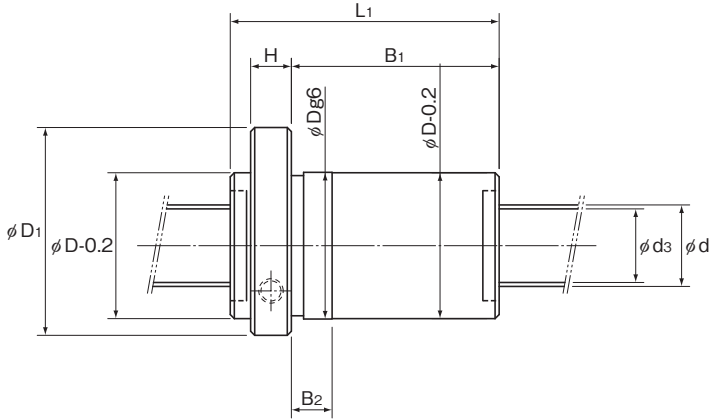

Unit: mm

Nut dimensions											
Outer diameter	Flange diameter	Overall length					Hole type	PCD	d ₁	Tw	Greasing hole
D	D ₁	L ₁	H	B ₁	B ₂						A
28	48	55	10	40	12		1	38	5.5	20	M6×1
36	58	50	10	35	12		1	47	6.6	22	M6×1
40	62	50	10	35	12		1	51	6.6	24	M6×1
40	62	80	10	65	18		1	51	6.6	24	M6×1
40	62	85	10	70	18		1	51	6.6	24	M6×1
50	80	52	12	35	12		1	65	9	31	M6×1
50	80	57	12	40	12		1	65	9	31	M6×1
50	80	67	12	50	12		1	65	9	31	M6×1
50	80	82	12	65	18		1	65	9	31	M6×1
50	80	94	12	77	18		1	65	9	31	M6×1
63	93	70	14	51	12		2	78	9	35	M8×1
63	93	84	14	65	18		2	78	9	35	M8×1
63	93	94	14	75	18		2	78	9	35	M8×1
63	93	129	14	105	25		2	78	9	35	M8×1
75	110	96	16	75	18		2	93	11	42.5	M8×1
75	110	134	16	108	27		2	93	11	42.5	M8×1
90	125	119	18	96	18		2	108	11	47.5	M8×1
95	135	136	18	108	27		2	115	13.5	50	M8×1

Note) The rigidity values in the table represent spring constants each obtained from the load and the Elastic Deformation finish when providing an axial load 24% of the basic dynamic load rating (Ca).

These values do not include the rigidity of the components related to mounting the nut. Therefore, it is normally appropriate to regard roughly 80% of the value in the table as the actual value.

If the axial load (Fa) is not 0.24 Ca, the rigidity value (K_w) is obtained from the following equation.

$$K_w = K \left(\frac{F_a}{0.24 C_a} \right)^{\frac{1}{3}}$$

K: Rigidity value in the dimensional table.

Model EPA (Offset Preload Type)

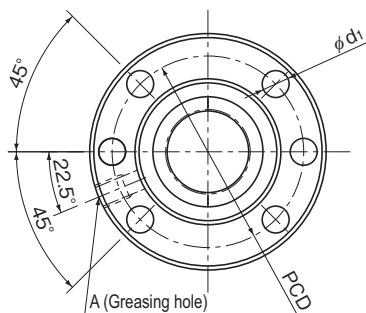

Hole type 1
(Model EPA1605 to 3210)

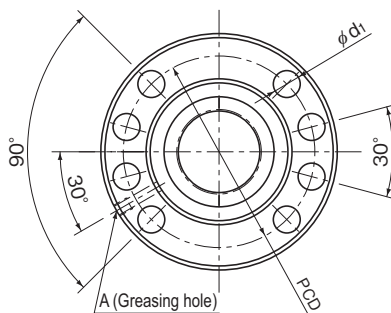

Hole type 2
(Model EPA4005 to 6310)

Model No.	Screw shaft outer diameter d	Lead ℓ	Ball diameter Da	Ball center-to-center diameter dp	Thread minor diameter d _s	No. of loaded circuits Rows x turns	Basic load rating		Rigidity K N/μm
							Ca* kN	C _a kN	
EPA 1605-6	16	5	3.175	16.75	13.1	3×1	9.3	13.1	317
EPA 2005-6	20	5	3.175	20.75	17.1	3×1	10.6	17.3	310
EPA 2505-6	25	5	3.175	25.75	22.1	3×1	12.1	22.6	490
EPA 2510-4	25	10	3.969	26	21.6	2×1	11.3	18	330
EPA 3205-6	32	5	3.175	32.75	29.2	3×1	13.9	30.2	620
EPA 3205-8	32	5	3.175	32.75	29.2	4×1	17.8	40.3	810
EPA 3210-6	32	10	6.35	33.75	26.4	3×1	32.1	52.2	600
EPA 4005-6	40	5	3.175	40.75	37.1	3×1	15.4	38.8	298
EPA 4010-6	40	10	6.35	41.75	34.7	3×1	37.3	69.3	750
EPA 4010-8	40	10	6.35	41.75	34.7	4×1	47.6	92.4	1000
EPA 5010-8	50	10	6.35	51.75	44.4	4×1	54.3	120.5	1230
EPA 6310-8	63	10	6.35	64.75	57.7	4×1	61.9	160.7	1550

Note) ★ Basic Dynamic Load Rating(Ca) of the accuracy C7 and Ct7 is 0.9Ca.

Model number coding

EP A 20 05 -6 QZ RR G0 +650L C3

EP: Flange shape: A: round; B: double chamfered; C: single chamfered
 A: Shaft diameter
 20: Number of turns
 05: Lead
 -6: Ball screw shaft length (mm)
 QZ: Seal symbol (RR: Labyrinth seal, WW: Wiper ring.)
 RR: With QZ Lubricator (no symbol without QZ Lubricator)
 G0: Clearance symbol
 +650L: Accuracy symbol
 C3: Nut type: offset preloaded type

DIN Standard compliant Ball Screw (DIN69051)

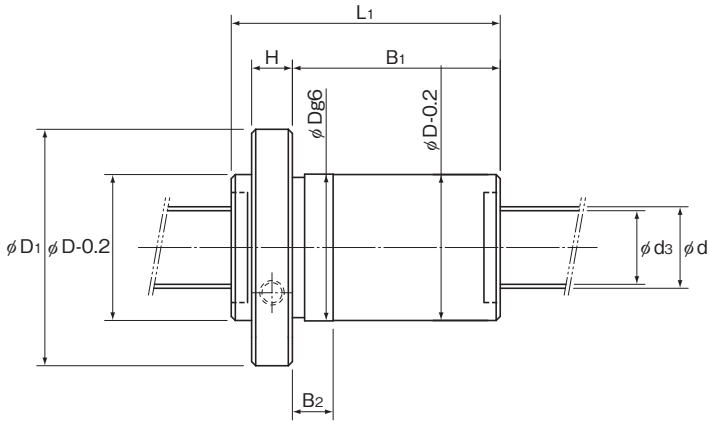

Unit: mm

Nut dimensions											
Outer diameter	Flange diameter	Overall length	H	B ₁	B ₂	Hole type	PCD	d ₁	Tw	Greasing hole	A
D	D ₁	L ₁									
28	48	65	10	50	12	1	38	5.5	20	M6×1	
36	58	66	10	51	12	1	47	6.6	22	M6×1	
40	62	66	10	51	12	1	51	6.6	24	M6×1	
40	62	85	10	70	18	1	51	6.6	24	M6×1	
50	80	67	12	50	12	1	65	9	31	M6×1	
50	80	78	12	61	12	1	65	9	31	M6×1	
50	80	112	12	95	18	1	65	9	31	M6×1	
63	93	70	14	51	12	2	78	9	35	M8×1	
63	93	114	14	95	18	2	78	9	35	M8×1	
63	93	138	14	119	18	2	78	9	35	M8×1	
75	110	140	16	119	18	2	93	11	42.5	M8×1	
90	125	142	18	119	18	2	108	11	47.5	M8×1	

Note) The rigidity values in the table represent spring constants each obtained from the load and the elastic deformation when providing a preload 8% of the basic dynamic load rating (Ca) and applying an axial load three times greater than the preload. These values do not include the rigidity of the components related to mounting the nut. Therefore, it is normally appropriate to regard roughly 80% of the value in the table as the actual value.

If the applied preload (Fa0) is not 0.08 Ca, the rigidity value (K_n) is obtained from the following equation.

$$K_n = K \left(\frac{Fa_0}{0.08Ca} \right)^{\frac{1}{3}}$$

K: Rigidity value in the dimensional table.

Model EPB (Offset Preload Type)

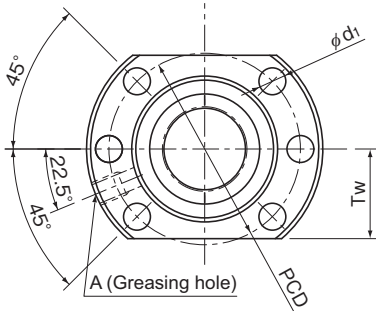

Hole type 1
(Model EPB1605 to 3210)

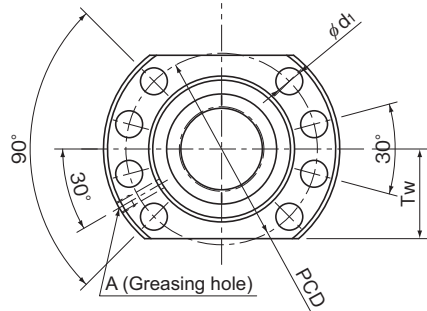

Hole type 2
(Model EPB4005 to 6310)

Model No.	Screw shaft outer diameter d	Lead ℓ	Ball diameter Da	Ball center-to-center diameter dp	Thread minor diameter d ₃	No. of loaded circuits Rows x turns	Basic load rating		Rigidity K N/μm
							Ca* kN	C _a kN	
EPB 1605-6	16	5	3.175	16.75	13.1	3×1	9.3	13.1	317
EPB 2005-6	20	5	3.175	20.75	17.1	3×1	10.6	17.3	310
EPB 2505-6	25	5	3.175	25.75	22.1	3×1	12.1	22.6	490
EPB 2510-4	25	10	3.969	26	21.6	2×1	11.3	18	330
EPB 3205-6	32	5	3.175	32.75	29.2	3×1	13.9	30.2	620
EPB 3205-8	32	5	3.175	32.75	29.2	4×1	17.8	40.3	810
EPB 3210-6	32	10	6.35	33.75	26.4	3×1	32.1	52.2	600
EPB 4005-6	40	5	3.175	40.75	37.1	3×1	15.4	38.8	298
EPB 4010-6	40	10	6.35	41.75	34.7	3×1	37.3	69.3	750
EPB 4010-8	40	10	6.35	41.75	34.7	4×1	47.6	92.4	1000
EPB 5010-8	50	10	6.35	51.75	44.4	4×1	54.3	120.5	1230
EPB 6310-8	63	10	6.35	64.75	57.7	4×1	61.9	160.7	1550

Note) ★ Basic Dynamic Load Rating(Ca) of the accuracy C7 and Ct7 is 0.9Ca.

Model number coding

EP B 20 05 -6 QZ RR G0 +650L C3

EP: Flange shape: A: round; B: double chamfered; C: single chamfered
 B: Shaft diameter
 20: Ball screw shaft length (mm)
 05: Number of turns
 -6: Lead
 QZ: Seal symbol (RR : Labyrinth seal, WW : Wiper ring.)
 RR: With QZ Lubricator (no symbol without QZ Lubricator)
 G0: Clearance symbol
 +650L: Accuracy symbol
 C3: Nut type: offset preloaded type

DIN Standard compliant Ball Screw (DIN69051)

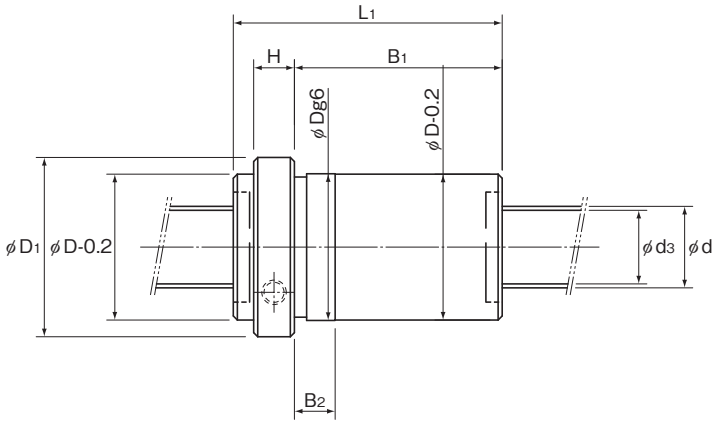

Unit: mm

Nut dimensions											
Outer diameter	Flange diameter	Overall length	H	B ₁	B ₂	Hole type	PCD	d ₁	Tw	Greasing hole	A
D	D ₁	L ₁									
28	48	65	10	50	12	1	38	5.5	20	M6×1	
36	58	66	10	51	12	1	47	6.6	22	M6×1	
40	62	66	10	51	12	1	51	6.6	24	M6×1	
40	62	85	10	70	18	1	51	6.6	24	M6×1	
50	80	67	12	50	12	1	65	9	31	M6×1	
50	80	78	12	61	12	1	65	9	31	M6×1	
50	80	112	12	95	18	1	65	9	31	M6×1	
63	93	70	14	51	12	2	78	9	35	M8×1	
63	93	114	14	95	18	2	78	9	35	M8×1	
63	93	138	14	119	18	2	78	9	35	M8×1	
75	110	140	16	119	18	2	93	11	42.5	M8×1	
90	125	142	18	119	18	2	108	11	47.5	M8×1	

Note) The rigidity values in the table represent spring constants each obtained from the load and the elastic deformation when providing a preload 8% of the basic dynamic load rating (Ca) and applying an axial load three times greater than the preload. These values do not include the rigidity of the components related to mounting the nut. Therefore, it is normally appropriate to regard roughly 80% of the value in the table as the actual value.

If the applied preload (Fa0) is not 0.08 Ca, the rigidity value (K_n) is obtained from the following equation.

$$K_n = K \left(\frac{Fa0}{0.08Ca} \right)^{\frac{1}{3}}$$

K: Rigidity value in the dimensional table.

Model EPC (Offset Preload Type)

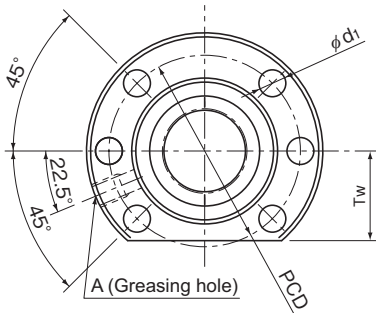

Hole type 1
(Model EPC1605 to 3210)

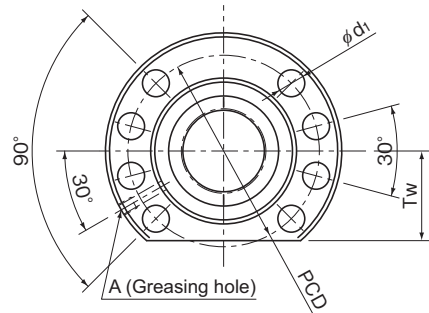

Hole type 2
(Model EPC4005 to 6310)

Model No.	Screw shaft outer diameter d	Lead ℓ	Ball diameter Da	Ball center-to-center diameter dp	Thread minor diameter d _s	No. of loaded circuits Rows x turns	Basic load rating		Rigidity K N/μm
							Ca* kN	C _a kN	
EPC 1605-6	16	5	3.175	16.75	13.1	3×1	9.3	13.1	317
EPC 2005-6	20	5	3.175	20.75	17.1	3×1	10.6	17.3	310
EPC 2505-6	25	5	3.175	25.75	22.1	3×1	12.1	22.6	490
EPC 2510-4	25	10	3.969	26	21.6	2×1	11.3	18	330
EPC 3205-6	32	5	3.175	32.75	29.2	3×1	13.9	30.2	620
EPC 3205-8	32	5	3.175	32.75	29.2	4×1	17.8	40.3	810
EPC 3210-6	32	10	6.35	33.75	26.4	3×1	32.1	52.2	600
EPC 4005-6	40	5	3.175	40.75	37.1	3×1	15.4	38.8	298
EPC 4010-6	40	10	6.35	41.75	34.7	3×1	37.3	69.3	750
EPC 4010-8	40	10	6.35	41.75	34.7	4×1	47.6	92.4	1000
EPC 5010-8	50	10	6.35	51.75	44.4	4×1	54.3	120.5	1230
EPC 6310-8	63	10	6.35	64.75	57.7	4×1	61.9	160.7	1550

Note) ★ Basic Dynamic Load Rating(Ca) of the accuracy C7 and Ct7 is 0.9Ca.

Model number coding

EP C 20 05 -6 QZ RR G0 +650L C3

EP: Flange shape: A: round; B: double chamfered; C: single chamfered
 C: Nut type: offset preloaded type
 20: Shaft diameter
 05: Lead
 -6: Number of turns
 QZ: Seal symbol (RR : Labyrinth seal, WW : Wiper ring.)
 RR: With QZ Lubricator (no symbol without QZ Lubricator)
 RR: Clearance symbol
 G0: Ball screw shaft length (mm)
 +650L: Accuracy symbol
 C3: Accuracy symbol

DIN Standard compliant Ball Screw (DIN69051)

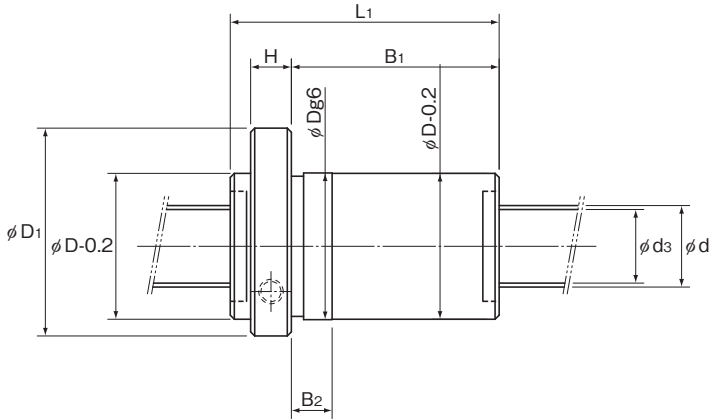

Unit: mm

Nut dimensions											
Outer diameter	Flange diameter	Overall length	H	B ₁	B ₂	Hole type	PCD	d ₁	Tw	Greasing hole	A
D	D ₁	L ₁									
28	48	65	10	50	12	1	38	5.5	20	M6×1	
36	58	66	10	51	12	1	47	6.6	22	M6×1	
40	62	66	10	51	12	1	51	6.6	24	M6×1	
40	62	85	10	70	18	1	51	6.6	24	M6×1	
50	80	67	12	50	12	1	65	9	31	M6×1	
50	80	78	12	61	12	1	65	9	31	M6×1	
50	80	112	12	95	18	1	65	9	31	M6×1	
63	93	70	14	51	12	2	78	9	35	M8×1	
63	93	114	14	95	18	2	78	9	35	M8×1	
63	93	138	14	119	18	2	78	9	35	M8×1	
75	110	140	16	119	18	2	93	11	42.5	M8×1	
90	125	142	18	119	18	2	108	11	47.5	M8×1	

Note) The rigidity values in the table represent spring constants each obtained from the load and the elastic deformation when providing a preload 8% of the basic dynamic load rating (Ca) and applying an axial load three times greater than the preload. These values do not include the rigidity of the components related to mounting the nut. Therefore, it is normally appropriate to regard roughly 80% of the value in the table as the actual value.
If the applied preload (Fa0) is not 0.08 Ca, the rigidity value (K_n) is obtained from the following equation.

$$K_n = K \left(\frac{Fa0}{0.08Ca} \right)^{\frac{1}{3}}$$

K: Rigidity value in the dimensional table.



SKSSWEDEN