

Precision Ball Screw/Spline

Models BNS-A, BNS, NS-A and NS

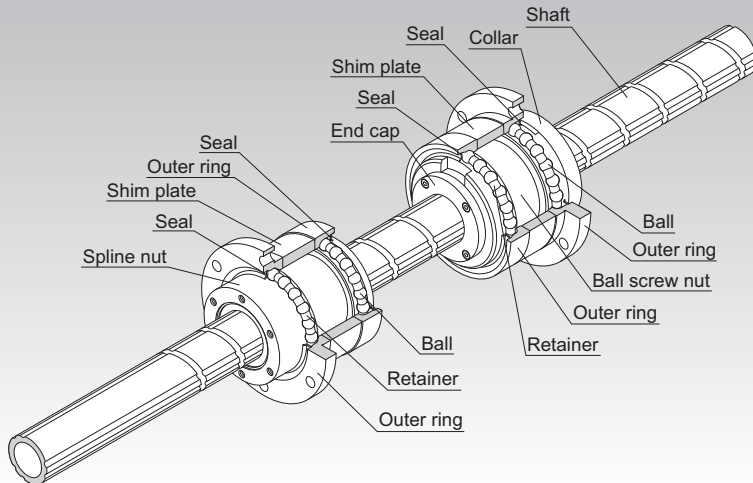

Point of Selection **A15-8**

Options **A15-352**

Model No. **A15-369**

Precautions on Use **A15-374**

Accessories for Lubrication **A24-1**

Mounting Procedure and Maintenance **B15-104**

DN Value **A15-33**

Accuracy Standards **A15-267**

Action Patterns **A15-268**

Example of Assembly **A15-271**

Example of Using the Spring Pad **A15-272**

Precautions on Use **A15-273**

Structure and Features

The Ball Screw/Spline contains the Ball Screw grooves and the Ball Spline groove crossing one another. The nuts of the Ball Screw and the Ball Spline have dedicated support bearings directly embedded on the circumference of the nuts.

The Ball Screw/Spline is capable of performing three (rotational, linear and spiral) modes of motion with a single shaft by rotating or stopping the spline nut.

It is optimal for machines using a combination of rotary and straight motions, such as scholar robot's Z-axis, assembly robot, automatic loader, and machining center's ATC equipment.

[Zero Axial Clearance]

The Ball Spline has an angular-contact structure that causes no backlash in the rotational direction, enabling highly accurate positioning.

[Lightweight and Compact]

Since the nut and the support bearing are integrated, highly accurate, compact design is achieved. In addition, small inertia because of the lightweight ball screw nut ensures high responsiveness.

[Easy Installation]

The Ball Spline nut is designed so that balls do not fall off even if the spline nut is removed from the shaft, making installation easy. The Ball Screw/Spline can easily be mounted simply by securing it to the housing with bolts. (For the housing's inner-diameter tolerance, H7 is recommended.)

[Smooth Motion with Low Noise]

As the Ball Screw is based on an end cap mechanism, smooth motion with low noise is achieved.

[Highly Rigid Support Bearing]

The support bearing on the Ball Screw has a contact angle of 60° in the axial direction while that on the Ball Spline has a contact angle of 30° in the moment direction, thus to provide a highly rigid shaft support.

In addition, a dedicated rubber seal is attached as standard to prevent entry of foreign materials.

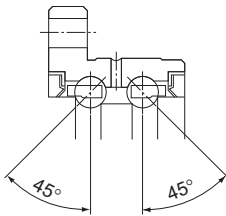

Fig.1 Structure of Support Bearing Model BNS-A

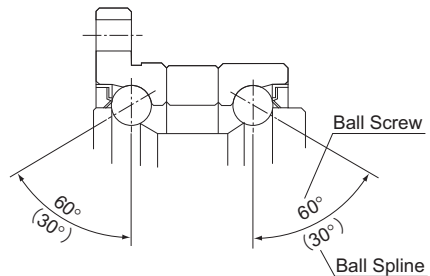

Fig.2 Structure of Support Bearing Model BNS

Type

[No Preload Type]

Model BNS-A

Specification Table⇒ **A15-274**

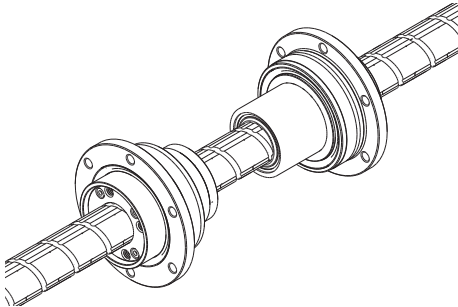

(Compact type: linear-rotary motion)

Model BNS

Specification Table⇒ **A15-276**

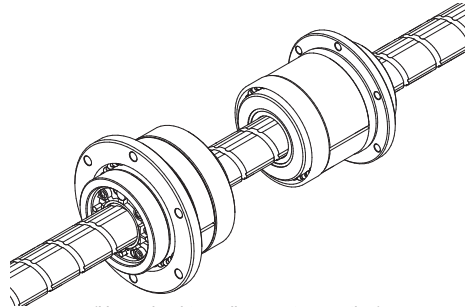

(Heavy-load type: linear-rotary motion)

Model NS-A

Specification Table⇒ **A15-278**

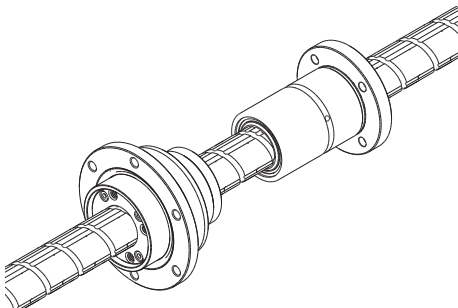

(Compact type: straight motion)

Model NS

Specification Table⇒ **A15-280**

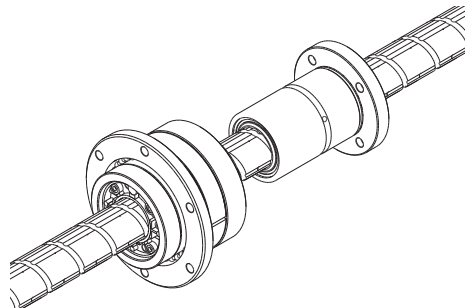

(Heavy-load type: straight motion)

Accuracy Standards

The Ball Screw/Spline is manufactured with the following specifications.

[Ball Screw]

Axial clearance : 0 or less

Lead angle accuracy : C5

(For detailed specifications, see **A15-12**, **A15-19**.)

[Ball Spline]

Clearance in the rotational direction : 0 or less (CL: light preload)

(For detailed specifications, see **A3-29**.)

Accuracy grade : class H

(For detailed specifications, see **A3-33**.)

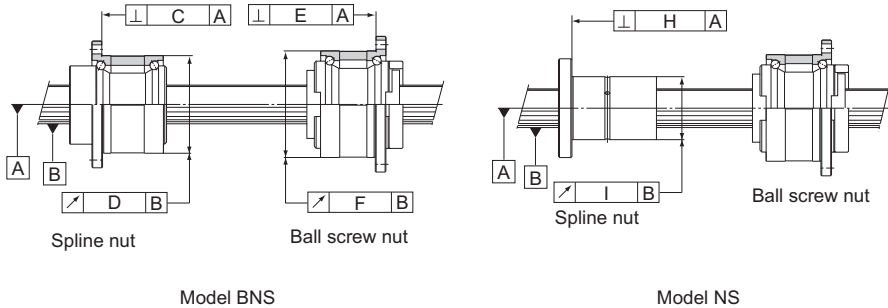

Unit: mm

Model No.	C	D	E	F	H	I
BNS 0812 NS 0812	0.014	0.017	0.014	0.016	0.010	0.013
BNS 1015 NS 1015	0.014	0.017	0.014	0.016	0.010	0.013
BNS 1616 NS 1616	0.018	0.021	0.016	0.020	0.013	0.016
BNS 2020 NS 2020	0.018	0.021	0.016	0.020	0.013	0.016
BNS 2525 NS 2525	0.021	0.021	0.018	0.024	0.016	0.016
BNS 3232 NS 3232	0.021	0.021	0.018	0.024	0.016	0.016
BNS 4040 NS 4040	0.025	0.025	0.021	0.033	0.019	0.019
BNS 5050 NS 5050	0.025	0.025	0.021	0.033	0.019	0.019

Action Patterns

[Model BNS Basic Actions]

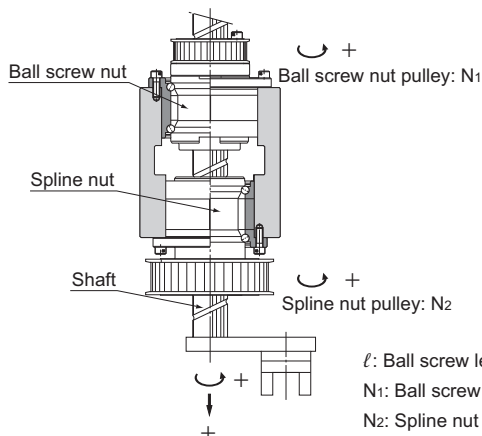

ℓ : Ball screw lead (mm)

N_1 : Ball screw nut rotational speed (min^{-1})

N_2 : Spline nut rotational speed (min^{-1})

Motion	Action direction	Input		Shaft motion	
		Ball screw pulley	Ball spline pulley	Vertical direction (speed)	Rotational direction (rotation speed)
1. Vertical 	(1) Vertical direction → down Rotational direction → 0	N_1 (Forward)	0	$V = N_1 \cdot \ell$ ($N_1 \neq 0$)	0
	(2) Vertical direction → up Rotational direction → 0	$-N_1$ (Reverse)	0	$V = -N_1 \cdot \ell$ ($N_1 \neq 0$)	0
2. Rotation 	(1) Vertical direction → 0 Rotational direction → forward	N_1	N_2 (Forward)	0	N_2 (Forward) ($N_1 = N_2 \neq 0$)
	(2) Vertical direction → 0 Rotational direction → reverse	$-N_1$	$-N_2$ (Reverse)	0	$-N_2$ (Reverse) ($-N_1 = -N_2 \neq 0$)
3. Spiral 	(1) Vertical direction → up Rotational direction → forward	0	N_2 ($N_2 \neq 0$)	$V = N_2 \cdot \ell$	N_2 (Forward)
	(2) Vertical direction → down Rotational direction → reverse	0	$-N_2$ ($-N_2 \neq 0$)	$V = -N_2 \cdot \ell$	$-N_2$ (Reverse)

[Model NS Basic Actions]

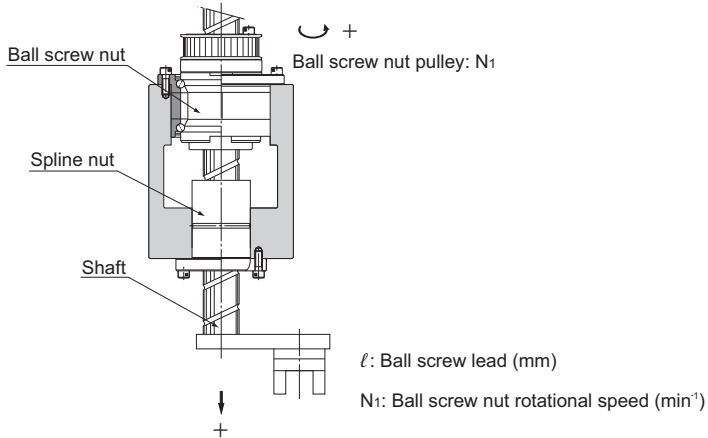

Motion	Action direction	Input	Shaft motion	
		Ball screw pulley	Vertical direction (speed)	
1. Vertical 	(1)	Vertical direction →down	N_1 (Forward)	$V=N_1 \cdot \ell$ ($N_1 \neq 0$)
	(2)	Vertical direction →up	$-N_1$ (Reverse)	$V=-N_1 \cdot \ell$ ($N_1 \neq 0$)

[Model BNS Extended Actions]

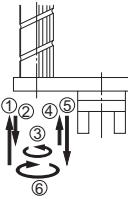
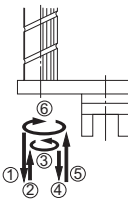
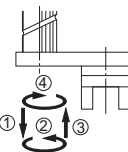
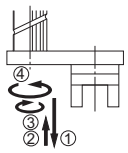
Motion	Action direction	Input		Shaft motion	
		Ball screw pulley	Ball spline pulley	Vertical direction (speed)	Rotational direction (rotational speed)
1. Up→down→forward →up→down→reverse 	(1)	Vertical direction→up $-N_1$ (Reverse)	0	$V=-N_1 \cdot \ell$ ($N_1 \neq 0$)	0
	(2)	Vertical direction→down N_1 (Forward)	0	$V=N_1 \cdot \ell$ ($N_1 \neq 0$)	0
	(3)	Rotational direction→forward N_1	N_2 (Forward)	0	N_2 (Forward) ($N_1=N_2 \neq 0$)
	(4)	Vertical direction→up $-N_1$	0	$V=-N_1 \cdot \ell$ ($N_1 \neq 0$)	0
	(5)	Vertical direction→down N_1	0	$V=N_1 \cdot \ell$ ($N_1 \neq 0$)	0
	(6)	Rotational direction→reverse $-N_1$	$-N_2$ (Reverse)	0	$-N_2$ (Reverse) ($-N_1=N_2 \neq 0$)
2. Down→up→forward →down→up→reverse 	(1)	Vertical direction→down N_1	0	$V=N_1 \cdot \ell$ ($N_1 \neq 0$)	0
	(2)	Vertical direction→up $-N_1$	0	$V=-N_1 \cdot \ell$ ($N_1 \neq 0$)	0
	(3)	Rotational direction→forward N_1	N_2	0	N_2 ($N_1=N_2 \neq 0$)
	(4)	Vertical direction→down N_1	0	$V=N_1 \cdot \ell$ ($N_1 \neq 0$)	0
	(5)	Vertical direction→up $-N_1$	0	$V=-N_1 \cdot \ell$ ($N_1 \neq 0$)	0
	(6)	Rotational direction→reverse $-N_1$	$-N_2$	0	$-N_2$ ($-N_1=N_2 \neq 0$)
3. Down→forward →up→reverse 	(1)	Vertical direction→down N_1	0	$V=N_1 \cdot \ell$ ($N_1 \neq 0$)	0
	(2)	Rotational direction→forward N_1	N_2	0	N_2 ($N_1=N_2 \neq 0$)
	(3)	Vertical direction→up $-N_1$	0	$V=-N_1 \cdot \ell$ ($N_1 \neq 0$)	0
	(4)	Rotational direction→reverse $-N_1$	$-N_2$	0	$-N_2$ ($-N_1=N_2 \neq 0$)
4. Down→up →reverse→forward 	(1)	Vertical direction→down N_1	0	$V=N_1 \cdot \ell$ ($N_1 \neq 0$)	0
	(2)	Vertical direction→up $-N_1$	0	$V=-N_1 \cdot \ell$ ($N_1 \neq 0$)	0
	(3)	Rotational direction→reverse $-N_1$	$-N_2$	0	$-N_2$ ($-N_1=N_2 \neq 0$)
	(4)	Rotational direction→forward N_1	N_2	0	N_2 ($N_1=N_2 \neq 0$)

Example of Assembly

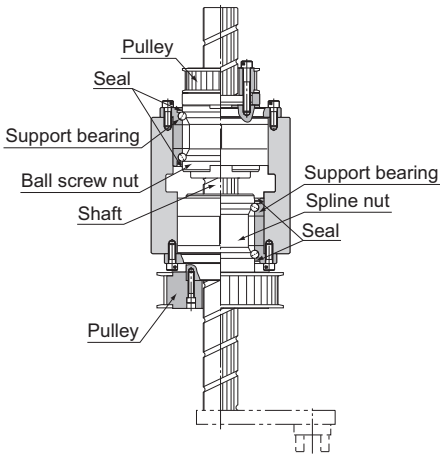

- Example of installing the ball screw nut input pulley

and the spline nut input pulley, both outside the housing.

The housing length is minimized.

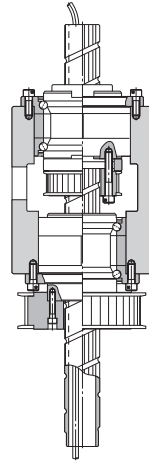

- Example of installing the ball screw nut pulley

inside the housing.

Fig.3 Example of Assembling Model BNS

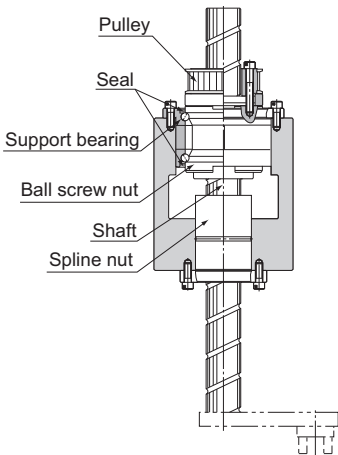

- Example of installing the ball screw nut pulley outside

the housing.

The housing length is minimized.

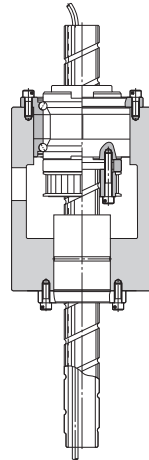

- Example of installing the ball screw nut pulley

inside the housing.

Fig.4 Example of Assembling Model NS

Example of Using the Spring Pad

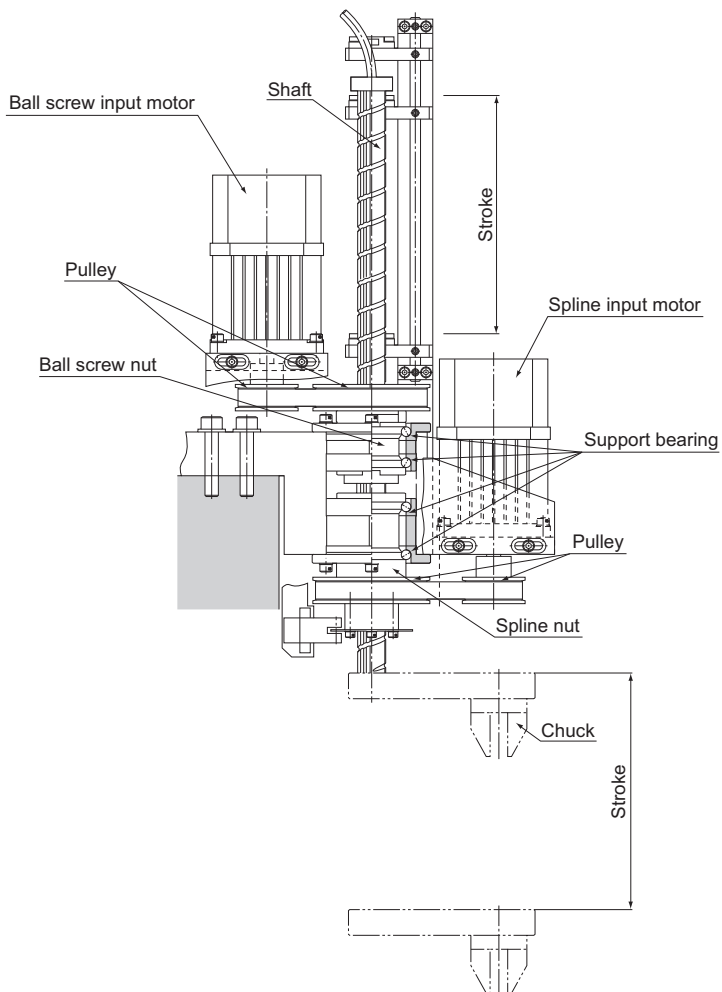

Fig.5 Example of Using Model BNS

Precautions on Use

[Lubrication]

When lubricating the Ball Screw/Spline, attach the greasing plate to the housing in advance.

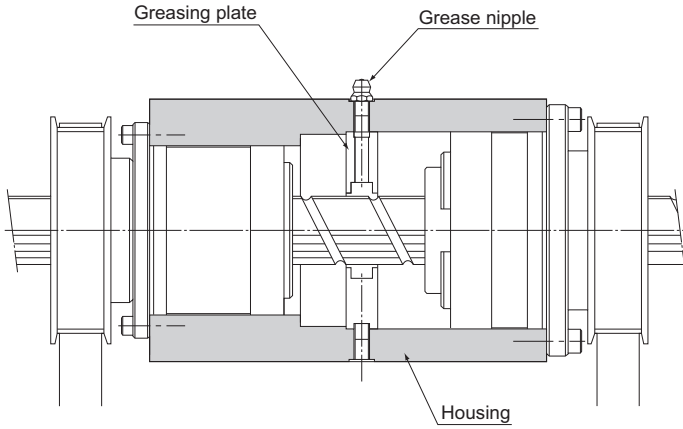
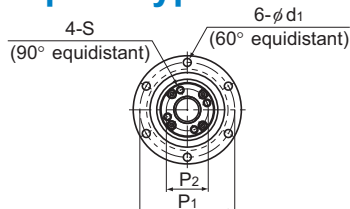
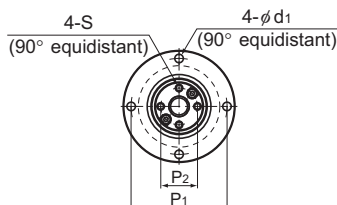

Fig.6 Lubrication Methods

Model BNS-A Compact Type: Linear-Rotary Motion



Ball screw unit
(Models BNS 1616A to 4040A)



Ball spline unit
(Models BNS 0812A and 1015A)

Ball screw unit

Model No.	Screw shaft outer diameter d	Screw shaft inner diameter db	Lead Ph	Ball screw dimensions								
				Basic load rating		Ball center-to-center diameter dp	Thread minor diameter dc	Outer diameter D	Flange diameter D ₁	Overall length L ₁	D ₃ h7	D ₄ H7
				C _a kN	C _{0a} kN							
BNS 0812A	8	—	12	1.1	1.8	8.4	6.6	32	44	28.5	22	19
BNS 1015A	10	—	15	1.7	2.7	10.5	8.3	36	48	34.5	26	23
BNS 1616A	16	11	16	3.9	7.2	16.65	13.7	48	64	40	36	32
BNS 2020A	20	14	20	6.1	12.3	20.75	17.5	56	72	48	48	39
BNS 2525A	25	18	25	9.1	19.3	26	21.9	66	86	58	52	47
BNS 3232A	32	23	32	13	29.8	33.25	28.3	78	103	72	63	58
BNS 4040A	40	29	40	21.4	49.7	41.75	35.2	100	130	88	79.5	73

Ball spline

Model No.	Ball spline dimensions									
	Basic load rating		Static permissible moment M _A N·m	Basic torque rating		Outer diameter D ₇ g6	Flange diameter D ₅	Overall length L ₂	D ₆ h7	BE ₁
	C kN	C ₀ kN		C _T N·m	C _{0T} N·m					
BNS 0812A	1.5	2.6	5.9	2	2.9	32	44	25	24	16
BNS 1015A	2.7	4.9	15.7	3.9	7.8	36	48	33	28	21
BNS 1616A	7.1	12.6	67.6	31.4	34.3	48	64	50	36	31
BNS 2020A	10.2	17.8	118	56.8	55.8	56	72	63	43.5	35
BNS 2525A	15.2	25.8	210	105	103	66	86	71	52	42
BNS 3232A	20.5	34	290	180	157	78	103	80	63	52
BNS 4040A	37.8	60.5	687	418	377	100	130	100	79.5	64

Note) For K hollow shaft, please refer to the db dimension for the inner bore diameter of the shaft. If requested solid shaft is also available. See "Ball Spline" **A3-106** for details.

Model number coding

BNS2020A +500L

Model number Overall shaft length (in mm)

Precision Ball Screw/Spline

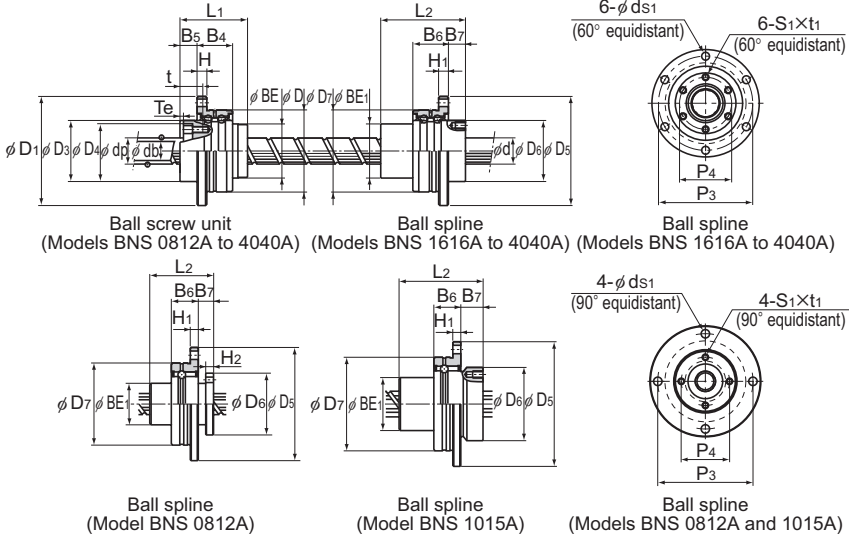

Unit: mm

	BE	H	B ₄	B ₅	T _e	P ₁	P ₂	S	t	d ₁	Support bearing basic load rating		Nut inertial moment kg·cm ²	Screw shaft inertial moment/mm J kg·cm ² /mm	Nut mass kg	Shaft mass kg/m
											Ca	C _{0a}				
	19	3	10.5	7	1.5	38	14.5	M2.6	10	3.4	0.8	0.5	0.03	3.16 × 10 ⁻⁵	0.08	0.35
	23	3	10.5	8	1.5	42	18	M3	11.5	3.4	0.9	0.7	0.08	7.71 × 10 ⁻⁵	0.15	0.52
	32	6	21	10	2	56	25	M4	13.5	4.5	8.7	10.5	0.35	3.92 × 10 ⁻⁴	0.31	0.8
	39	6	21	11	2.5	64	31	M5	16.5	4.5	9.7	13.4	0.85	9.37 × 10 ⁻⁴	0.54	1.21
	47	7	25	13	3	75	38	M6	20	5.5	12.7	18.2	2.12	2.2 × 10 ⁻³	0.88	1.79
	58	8	25	14	3	89	48	M6	21	6.6	13.6	22.3	5.42	5.92 × 10 ⁻³	1.39	2.96
	73	10	33	16.5	3	113	61	M8	24.5	9	21.5	36.8	17.2	1.43 × 10 ⁻²	3.16	4.51

Unit: mm

	H ₁	B ₆	B ₇	H ₂	P ₃	P ₄	S ₁ × t ₁	ds ₁	Support bearing basic load rating		Nut inertial moment kg·cm ²	Nut mass kg
									C	C ₀		
	3	10.5	6	3	38	19	M2.6 × 3	3.4	0.6	0.2	0.03	0.08
	3	10.5	9	—	42	23	M3 × 4	3.4	0.8	0.3	0.08	0.13
	6	21	10	—	56	30	M4 × 6	4.5	6.7	6.4	0.44	0.35
	6	21	12	—	64	36	M5 × 8	4.5	7.4	7.8	0.99	0.51
	7	25	13	—	75	44	M5 × 8	5.5	9.7	10.6	2.2	0.79
	8	25	17	—	89	54	M6 × 10	6.6	10.5	12.5	5.17	1.25
	10	33	20	—	113	68	M6 × 10	9	16.5	20.7	16.1	2.51

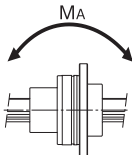

Model BNS Heavy-load Type: Linear-Rotary Motion

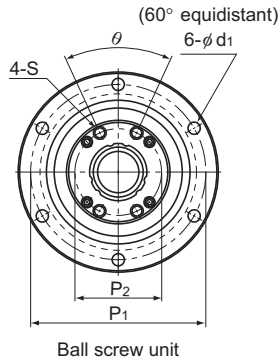

Ball screw unit

Model No.	Screw shaft outer diameter d	Screw shaft inner diameter db	Lead Ph	Ball screw dimensions							
				Basic load rating		Ball center-to-center diameter dp	Thread minor diameter dc	Outer diameter D	Flange diameter D ₁	Overall length L ₁	D ₃ h7
				Ca kN	C _{0a} kN						
BNS 1616	16	11	16	3.9	7.2	16.65	13.7	52 ⁰ _{-0.007}	68	43.5	40
BNS 2020	20	14	20	6.1	12.3	20.75	17.5	62 ⁰ _{-0.007}	78	54	50
BNS 2525	25	18	25	9.1	19.3	26	21.9	72 ⁰ _{-0.007}	92	65	58
BNS 3232	32	23	32	13	29.8	33.25	28.3	80 ⁰ _{-0.007}	105	80	66
BNS 4040	40	29	40	21.4	49.7	41.75	35.2	110 ⁰ _{-0.008}	140	98	90
BNS 5050	50	36	50	31.8	77.6	52.2	44.1	120 ⁰ _{-0.008}	156	126	100

Ball spline

Model No.	Ball spline dimensions							
	Basic load rating		Static permissible moment M _s N-m	Basic torque rating		Outer diameter D ₇	Flange diameter D ₅	Overall length L ₂
	C kN	C ₀ kN		C _T N-m	C _{0T} N-m			
BNS 1616	7.1	12.6	67.6	31.4	34.3	52 ⁰ _{-0.007}	68	50
BNS 2020	10.2	17.8	118	56.8	55.8	56 ⁰ _{-0.007}	72	63
BNS 2525	15.2	25.8	210	105	103	62 ⁰ _{-0.007}	78	71
BNS 3232	20.5	34	290	180	157	80 ⁰ _{-0.007}	105	80
BNS 4040	37.8	60.5	687	418	377	100 ⁰ _{-0.008}	130	100
BNS 5050	60.9	94.5	1340	842	768	120 ⁰ _{-0.008}	156	125

Note) Dimension U indicates the length from the head of the hexagonal-socket-head type bolt to the ball screw nut end.

For K hollow shaft, please refer to the db dimension for the inner bore diameter of the shaft. If requested solid shaft is also available. See "Ball Spline" **A3-106** for details.

Model number coding

BNS2525 +600L

Model number Overall shaft length (in mm)

Precision Ball Screw/Spline

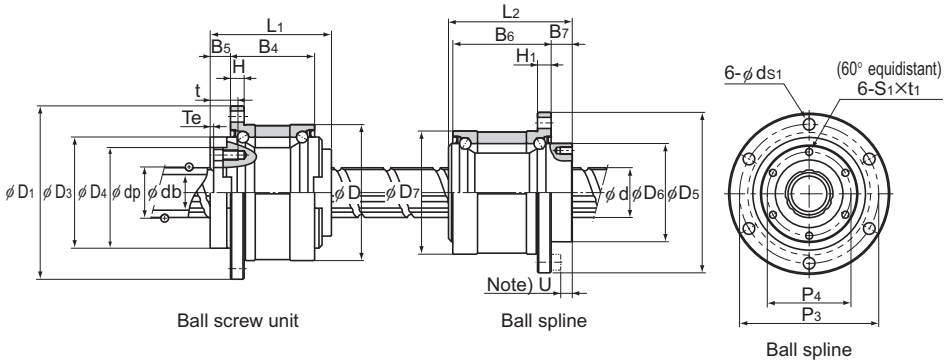

Unit: mm

D ₄	H	B ₄	B ₅	T _e	P ₁	P ₂	S	t	d ₁	θ°	Support bearing basic load rating		Nut inertial moment	Screw shaft inertial moment/mm	Nut mass	Shaft mass
											Ca	C _a				
											kN	kN	kg·cm ²	J kg·cm ² /mm	kg	kg/m
H7	5	27.5	9	2	60	25	M4	12	4.5	40	19.4	19.2	0.48	3.92 × 10 ⁻⁴	0.38	0.8
39	6	34	11	2	70	31	M5	16	4.5	40	26.8	29.3	1.44	9.37 × 10 ⁻⁴	0.68	1.21
47	8	43	12.5	3	81	38	M6	19	5.5	40	28.2	33.3	3.23	2.2 × 10 ⁻³	1.1	1.79
58	9	55	14	3	91	48	M6	19	6.6	40	30	39	6.74	5.92 × 10 ⁻³	1.74	2.96
73	11	68	16.5	3	123	61	M8	22	9	50	59.3	74.1	27.9	1.43 × 10 ⁻²	3.95	4.51
90	12	80	25	4	136	75	M10	28	11	50	62.2	83	58.2	3.52 × 10 ⁻²	6.22	7.16

Unit: mm

D ₆	h ₇	H ₁	B ₆	B ₇	P ₃	P ₄	S ₁ × t ₁	d _{s1}	U	Support bearing basic load rating		Nut inertial moment	Nut mass
										C	C ₀		
										kN	kN	kg·cm ²	kg
39.5	5	37	10	60	32	32	M5 × 8	4.5	5	12.7	11.8	0.52	0.51
43.5	6	48	12	64	36	36	M5 × 8	4.5	7	16.2	15.5	0.87	0.7
53	6	55	13	70	45	45	M6 × 8	4.5	8	17.6	18	1.72	0.93
65.5	9	60	17	91	55	55	M6 × 10	6.6	10	20.1	24	5.61	1.8
79.5	11	74	23	113	68	68	M6 × 10	9	13	37.2	42.5	14.7	3.9
99.5	12	97	25	136	85	85	M10 × 15	11	13	41.6	54.1	62.5	6.7

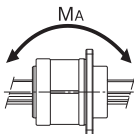

Model NS-A Compact Type: Straight Motion

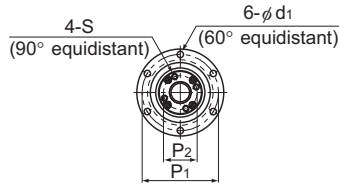

Ball screw unit
(Models NS 1616A to 4040A)

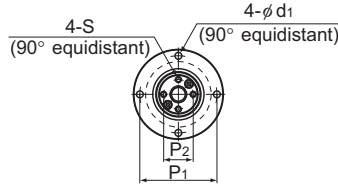

Ball screw unit
(Models NS 0812A and 1015A)

Ball screw unit

Model No.	Screw shaft outer diameter d	Screw shaft inner diameter db	Lead Ph	Ball screw dimensions									
				Basic load rating		Ball center-to-center diameter dp	Thread minor diameter dc	Outer diameter D	Flange diameter D ₁	Overall length L ₁	D ₃ h7	D ₄ H7	
				Ca kN	C _{0a} kN								
NS 0812A	8	—	12	1.1	1.8	8.4	6.6	32	44	28.5	22	19	
NS 1015A	10	—	15	1.7	2.7	10.5	8.3	36	48	34.5	26	23	
NS 1616A	16	11	16	3.9	7.2	16.65	13.7	48	64	40	36	32	
NS 2020A	20	14	20	6.1	12.3	20.75	17.5	56	72	48	43.5	39	
NS 2525A	25	18	25	9.1	19.3	26	21.9	66	86	58	52	47	
NS 3232A	32	23	32	13	29.8	33.25	28.3	78	103	72	63	58	
NS 4040A	40	29	40	21.4	49.7	41.75	35.2	100	130	88	79.5	73	

Ball spline

Model No.	Ball spline dimensions						
	Basic load rating		Static permissible moment M _A N-m	Basic torque rating		Outer diameter D ₇	Flange diameter D ₅ ⁰ _{-0.2}
	C kN	C ₀ kN		C _T N-m	C _{0T} N-m		
NS 0812A	1.5	2.6	5.9	2	2.9	16 ⁰ _{-0.011}	32
NS 1015A	2.8	4.9	15.7	3.9	7.8	21 ⁰ _{-0.013}	42
NS 1616A	7.1	12.6	67.6	31.4	34.3	31 ⁰ _{-0.013}	51
NS 2020A	10.2	17.8	118	56.8	55.8	35 ⁰ _{-0.016}	58
NS 2525A	15.2	25.8	210	105	103	42 ⁰ _{-0.016}	65
NS 3232A	20.5	34	290	180	157	49 ⁰ _{-0.016}	77
NS 4040A	37.8	60.5	687	418	377	64 ⁰ _{-0.019}	100

Note) For K hollow shaft, please refer to the db dimension for the inner bore diameter of the shaft. If requested solid shaft is also available. See "Ball Spline" **A3-106** for details.

Model number coding

NS2020A +500L

Model number Overall shaft length (in mm)

Precision Ball Screw/Spline

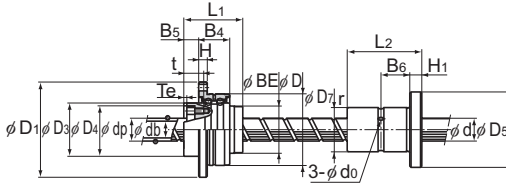

Ball screw unit (Models NS 1616A to 4040A) Ball spline (Models NS 1616A to 4040A)

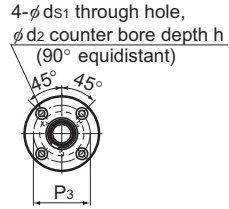

Ball spline (Models NS 1616A to 4040A)

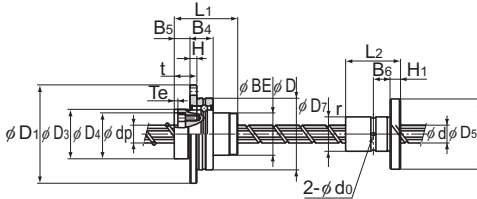

Ball screw unit (Models NS 0812A and 1015A) Ball spline (Models NS 0812A and 1015A)

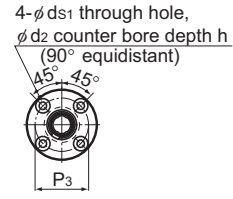

Ball spline (Models NS 0812A and 1015A)

Unit: mm

	BE	H	B ₄	B ₅	T _e	P ₁	P ₂	S	t	d ₁	Support bearing basic load rating		Nut inertial moment	Screw shaft inertial moment/mm	Nut mass	Shaft mass
											C _a	C _{0a}				
											kN	kN	kg·cm ²	J kg·cm ² /mm	kg	kg/m
	19	3	10.5	7	1.5	38	14.5	M2.6	10	3.4	0.8	0.5	0.03	3.16 × 10 ⁻⁵	0.08	0.35
	23	3	10.5	8	1.5	42	18	M3	11.5	3.4	0.9	0.7	0.08	7.71 × 10 ⁻⁵	0.15	0.52
	32	6	21	10	2	56	25	M4	13.5	4.5	8.7	10.5	0.35	3.92 × 10 ⁻⁴	0.31	0.8
	39	6	21	11	2.5	64	31	M5	16.5	4.5	9.7	13.4	0.85	9.37 × 10 ⁻⁴	0.54	1.21
	47	7	25	13	3	75	38	M6	20	5.5	12.7	18.2	2.12	2.2 × 10 ⁻³	0.88	1.79
	58	8	25	14	3	89	48	M6	21	6.6	13.6	22.3	5.42	5.92 × 10 ⁻³	1.39	2.96
	73	10	33	16.5	3	113	61	M8	24.5	9	21.5	36.8	17.2	1.43 × 10 ⁻²	3.16	4.51

Unit: mm

Overall length	H ₁	B ₆	r	Greasing hole	d ₀	P ₃	Mounting hole			Nut mass
							d _{s1}	d ₂	h	
L ₂									kg	
25	5	7.5	0.5	1.5	1.5	24	3.4	6.5	3.3	0.04
33	6	10.5	0.5	1.5	1.5	32	4.5	8	4.4	0.09
50 ^{+0.2}	7	18	0.5	2	2	40	4.5	8	4.4	0.23
63 ^{+0.2}	9	22.5	0.5	2	2	45	5.5	9.5	5.4	0.33
71 ^{+0.3}	9	26.5	0.5	3	3	52	5.5	9.5	5.4	0.45
80 ^{+0.3}	10	30	0.5	3	3	62	6.6	11	6.5	0.58
100 ^{+0.3}	14	36	0.5	4	4	82	9	14	8.6	1.46

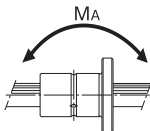

Ball Screw

Model NS Heavy-load Type: Linear Motion

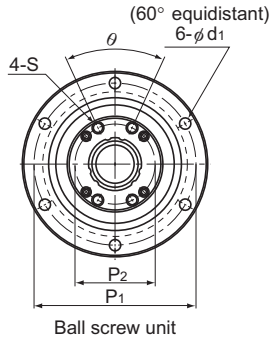

Ball screw unit

Model No.	Screw shaft outer diameter d	Screw shaft inner diameter db	Lead Ph	Ball screw dimensions							
				Basic load rating		Ball center-to-center diameter dp	Thread minor diameter dc	Outer diameter D	Flange diameter D ₁	Overall length L ₁	D ₃ h7
				Ca kN	C _{0a} kN						
NS 1616	16	11	16	3.9	7.2	16.65	13.7	52 ⁰ _{-0.007}	68	43.5	40
NS 2020	20	14	20	6.1	12.3	20.75	17.5	62 ⁰ _{-0.007}	78	54	50
NS 2525	25	18	25	9.1	19.3	26	21.9	72 ⁰ _{-0.007}	92	65	58
NS 3232	32	23	32	13	29.8	33.25	28.3	80 ⁰ _{-0.007}	105	80	66
NS 4040	40	29	40	21.4	49.7	41.75	35.2	110 ⁰ _{-0.008}	140	98	90
NS 5050	50	36	50	31.8	77.6	52.2	44.1	120 ⁰ _{-0.008}	156	126	100

Ball spline

Model No.	Ball spline dimensions					
	Basic load rating		Static permissible moment M _k N-m	Basic torque rating		Outer diameter D ₇
	C kN	C ₀ kN		C _T N-m	C _{0T} N-m	
NS 1616	7.1	12.6	67.6	31.4	34.3	31 ⁰ _{-0.013}
NS 2020	10.2	17.8	118	56.9	55.9	35 ⁰ _{-0.016}
NS 2525	15.2	25.8	210	105	103	42 ⁰ _{-0.016}
NS 3232	20.5	34	290	180	157	49 ⁰ _{-0.016}
NS 4040	37.8	60.5	687	419	377	64 ⁰ _{-0.019}
NS 5050	60.9	94.5	1340	842	769	80 ⁰ _{-0.019}

Note) For K hollow shaft, please refer to the db dimension for the inner bore diameter of the shaft. If requested solid shaft is also available. See "Ball Spline" **A3-106** for details.

Model number coding

NS2525 +600L

Model number Overall shaft length (in mm)

Precision Ball Screw/Spline

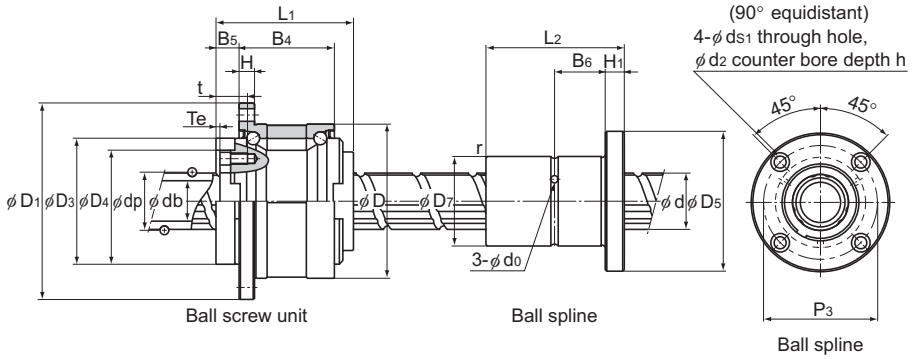

Unit: mm

D ₄	H7	H	B ₄	B ₅	T _e	P ₁	P ₂	S	t	d ₁	θ°	Support bearing basic load rating		Nut inertial moment kg·cm ²	Screw shaft inertial moment/mm J kg·cm ² /mm	Nut mass kg	Shaft mass kg/m
												C _a kN	C _{0a} kN				
32	5	27.5	9	2	60	25	M4	12	4.5	40	19.4	19.2	0.48	3.92×10^{-4}	0.38	0.8	
39	6	34	11	2	70	31	M5	16	4.5	40	26.8	29.3	1.44	9.37×10^{-4}	0.68	1.21	
47	8	43	12.5	3	81	38	M6	19	5.5	40	28.2	33.3	3.23	2.2×10^{-3}	1.1	1.79	
58	9	55	14	3	91	48	M6	19	6.6	40	30	39	6.74	5.92×10^{-3}	1.74	2.96	
73	11	68	16.5	3	123	61	M8	22	9	50	59.3	74.1	27.9	1.43×10^{-2}	3.95	4.51	
90	12	80	25	4	136	75	M10	28	11	50	62.2	83	58.2	3.52×10^{-2}	6.22	7.16	

Unit: mm

Flange diameter D ₅	Overall length L ₂	H ₁	B ₆	r	Greasing hole d ₀	P ₃	Mounting hole			Nut mass kg
							d _{s1}	d ₂	h	
51	50 ⁰ _{-0.2}	7	18	0.5	2	40	4.5	8	4.4	0.23
58	63 ⁰ _{-0.2}	9	22.5	0.5	2	45	5.5	9.5	5.4	0.33
65	71 ⁰ _{-0.3}	9	26.5	0.5	3	52	5.5	9.5	5.4	0.45
77	80 ⁰ _{-0.3}	10	30	0.5	3	62	6.6	11	6.5	0.58
100	100 ⁰ _{-0.3}	14	36	0.5	4	82	9	14	8.6	1.46
124	125 ⁰ _{-0.3}	16	46.5	1	4	102	11	17.5	11	2.76

