

Dimensioner och Bärighetstal Skenstyrning THK HSV vagn R/LR

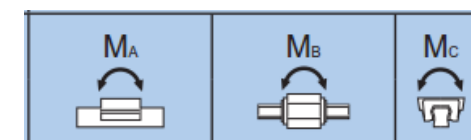
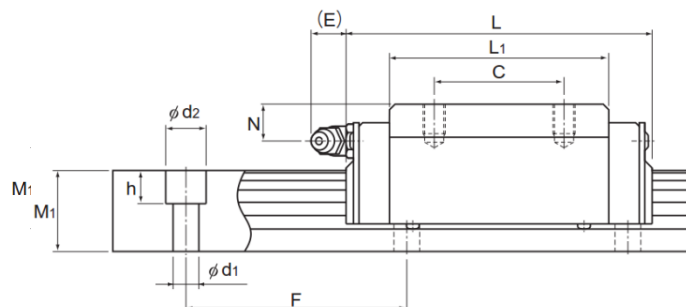
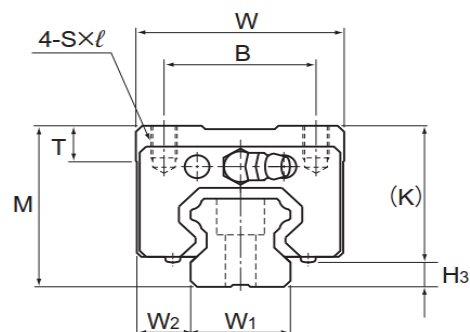

Typ	Yttre dimensioner			Dimensioner vagn									H ₃	Dimensioner skena					Bärighetstal		Statiskt tillåtet vridmoment (kNm)					Vikt (kg)		
	Höjd M	Bredd W	Längd L	B	C	S X ℓ	L ₁	T	K	N	E	Smörj- nippel		Bredd W ₁ +/-0,05	W ₂	Höjd M ₁	Deln F	d ₁ x d ₂ x h	Längd max*	C Dynamiskt (kN)	C ₀ Statiskt (kN)	M _A		M _B		M _C	Vagn	Skena per m
																						1 vagn	2 vagnar	1 vagn	2 vagnar	1 vagn		
HSV 15R	28	34	56,6	26	26	M4 X 5	38,8	6	23,3	8,3	5,5	PB1021B	4,7	15	9,5	15	60	4,5X7,5X5,3	3000	10,9	15,7	0,0945	0,527	0,0945	0,527	0,0998	0,18	1,5
HSV 20R HSV 20LR	30	44	74 90	32	36 50	M5 X 6	50,8 66,8	8	26	5	12	B-M6F	4	20	12	18	60	6X9,5X8,5	4540	19,8 23,9	27,4 35,8	0,218 0,363	1,2 1,87	0,218 0,363	1,2 1,87	0,235 0,307	0,25 0,35	2,3
HSV 25R HSV 25LR	40	48	83,1 102,2	35	35 50	M6 X 8	59,5 78,6	9	34,5	10	12	B-M6F	5,5	23	12,5	22	60	7 X 11 X 9	4540	27,6 35,2	36,4 51,6	0,324 0,627	1,8 3,04	0,324 0,627	1,8 3,04	0,366 0,518	0,54 0,67	3,3
HSV 30R HSV 30LR	45	60	98 120,6	40	40 60	M8 X 10	70,4 93	9	38	10	12	B-M6F	7	28	16	26	80	9 X 14 X 12	4520	40,5 48,9	53,7 70,2	0,599 0,995	3,1 4,89	0,599 0,995	3,1 4,89	0,652 0,852	0,9 1,1	4,8
HSV 35R HSV 35LR	55	70	109,4 134,8	50	50 72	M8 X 12	80,4 105,8	11,7	47,5	15	12	B-M6F	7,5	34	18	29	80	9 X 14 X 12	4520	53,9 65	70,2 91,7	0,895 1,49	4,51 7,13	0,895 1,49	4,51 7,13	1,05 1,37	1,5 2	6,6
HSV 45R	70	86	139	60	60	M10 X 17	98	15	60	20	16	B-PT1/8	10	45	20,5	38	105	14X20X17	3090	82,2	101	1,5	8,37	1,5	8,37	1,94	2,6	11

*Längd max indikerar maximal standard-längd. Fråga SKS vid önskemål om längre skena.